

## TWO-STAGE VARIABLE-SPEED ECM GAS FURNACE UP TO 96% AFUE

### Standard Features

- ComfortNet™ Communicating System compatible
- Heavy-duty stainless-steel tubular heat exchanger
- Stainless-steel secondary heat exchanger
- Two-stage gas valve provides quiet, economical heating
- Durable Silicon Nitride igniter
- Quiet two-speed induced draft blower
- Utilizes ComfortNet™ communicating, two-stage or single-stage thermostats
- Self-diagnostic control board with constant memory fault code history output to a dual 7-segment display
- Color-coded low-voltage terminals with provisions for electronic air cleaner and humidifier
- Efficient and quiet variable-speed airflow system gently ramps up or down according to heating or cooling demand
- Multiple continuous fan speed options offer quiet air circulation
- Auto-Comfort and enhanced dehumidification modes available
- All models comply with California Low NOx emissions standards

### Cabinet Features

- Designed for multi-position installation — downflow, horizontal left or right
- Certified for direct vent (2-pipe) or non-direct vent (1-pipe)
- Easy-to-install top venting with optional side venting
- Convenient left or right connection for gas and electrical service
- Cabinet air leakage ( $Q_{Leak}$ )  $\leq 2\%$
- Heavy-gauge steel cabinet with durable finish
- Fully insulated heat exchanger and blower section
- Airtight solid bottom or side return with easy-cut tabs for effortless removal in bottom air-inlet applications

**Heating Input: 40,000–120,000 BTU/h**

### Contents

Nomenclature.....	2
Product Specifications.....	3
Dimensions.....	4
Airflow Specifications.....	5
Wiring Diagram.....	9
Accessories.....	10
Thermostats.....	10



\* Complete warranty details available from your local dealer or at [www.daikincomfort.com](http://www.daikincomfort.com). To receive the Lifetime Heat Exchanger Limited Warranty (good for as long as you own your home), the 12-Year Unit Replacement Limited Warranty and the 12-Year Parts Limited Warranty, online registration must be completed within 60 days of installation. Additional requirements for annual maintenance are required for the Unit Replacement Limited Warranty. Online registration and some of the additional requirements are not required in California or Quebec.



# NOMENCLATURE

	D	C	96	V	C	080	3	B	N	A	A
	1	2	3,4	5	6	7,8,9	10	11	12	13	14
<b>Brand</b> D - Daikin											
<b>Configuration</b> M - Upflow/Horizontal C - Downflow/Horizontal											
<b>AFUE</b> 92 - 92% AFUE 96 - 96% AFUE 97 - 97% AFUE											
<b>Gas Valve</b> M - Modulating V - 2 Stage H - Convertible 2 Stage S - Single Stage											
<b>Motor</b> C - Variable Speed ECM / ComfortNet E - Multi-Speed ECM S - Single Speed											
<b>MBTU/h</b> 040 - 40,000 BTU/h 060 - 60,000 BTU/h 120 - 120,000 BTU/h											
	<b>Minor Revision</b>										
	A - Initial Release B - 1st Revision										
	<b>Major Revision</b>										
	A - Initial Release B - 1st Revision										
	<b>NOx</b>										
	N - Low NOx										
	<b>Cabinet Width</b>										
	B - 17.5" C - 21" D - 24.5"										
	<b>Maximum CFM</b>										
	2 - 800 CFM 3 - 1200 CFM 4 - 1600 CFM 5 - 2000 CFM										

# SPECIFICATIONS

	DC96VC 0403BNA	DC96VC 0603BNA	DC96VC 0804CNA	DC96VC 1005CNA	DC96VC 1205DNA
<b>Heating Data</b>					
High Fire Input <sup>1</sup>	40,000	60,000	80,000	100,000	120,000
High Fire Output <sup>1</sup>	38,400	57,600	76,800	96,000	115,200
Low-Fire Steady-State Input <sup>1</sup>	28,000	42,000	56,000	70,000	84,000
Low-Fire Steady-State Output <sup>1</sup>	26,880	40,320	53,760	67,200	80,640
AFUE <sup>2</sup>	96	96	96	96	96
Temperature Rise Range (°F)	20 - 50	35 - 65	25 - 55	45 - 75	35 - 65
Vent Diameter <sup>3</sup>	2" - 3"	2" - 3"	2" - 3"	2" - 3"	2" - 3"
No. of Burners	2	3	4	5	6
<b>Circulator Blower</b>					
Available AC @ 0.5" ESP	1.5 - 3	1.5 - 3	1.5 - 4	2 - 5	2 - 5
Size (D x W)	10" x 8"	11" x 8"	11" x 10"	11" x 10"	11" x 11"
Horsepower @ 1075 RPM	½	½	¾	1	1
Speed	VS ECM	VS ECM	VS ECM	VS ECM	VS ECM
<b>Filter Size (in<sup>2</sup>)</b>					
Permanent	488	512	853	711	1,024
Disposable	244	256	427	356	512
<b>Electrical Data</b>					
Min. Circuit Ampacity <sup>4</sup>	7.8	7.8	10.6	14.4	14.4
Max. Overcurrent Device (amps) <sup>5</sup>	15	15	15	20	20
<b>Shipping Weight (lbs)</b>					
	116	119	143	145	158

<sup>1</sup> Natural Gas BTU/h

<sup>2</sup> DOE AFUE based upon Isolated Combustion System (ICS)

<sup>3</sup> Installer must supply one or two PVC pipes: one for combustion air (optional) and one for the flue outlet (required). Vent pipe must be either 2" or 3" in diameter, depending upon furnace input, number of elbows, length of run and installation (1 or 2 pipes). The optional Combustion Air Pipe is dependent on installation/code requirements and must be 2" or 3" diameter PVC.

<sup>4</sup> Minimum Circuit Ampacity = (1.25 x Circulator Blower Amps) + ID Blower amps. Wire size should be determined in accordance with National Electrical Codes. Extensive wire runs will require larger wire sizes.

<sup>5</sup> Maximum Overcurrent Protection Device refers to maximum recommended fuse or circuit breaker size. May use fuses or HACR-type circuit breakers of the same size as noted.

**NOTES**

- All furnaces are manufactured for use on 115 VAC, 60 Hz, single-phase electrical supply.
- Gas Service Connection ½" FPT
- Important: Size fuses and wires properly and make electrical connections in accordance with the National Electrical Code and/or all existing local codes.
- For bottom return: Failure to unfold flanges may reduce airflow by up to 18%. This could result in performance and noise issues.
- For servicing or cleaning, a 24" front clearance is required. Unit connections (electrical, flue and drain) may necessitate greater clearances than the minimum clearances listed above. In all cases, accessibility clearance must take precedence over clearances from the enclosure where accessibility clearances are greater.

# DC96VC DIMENSIONS

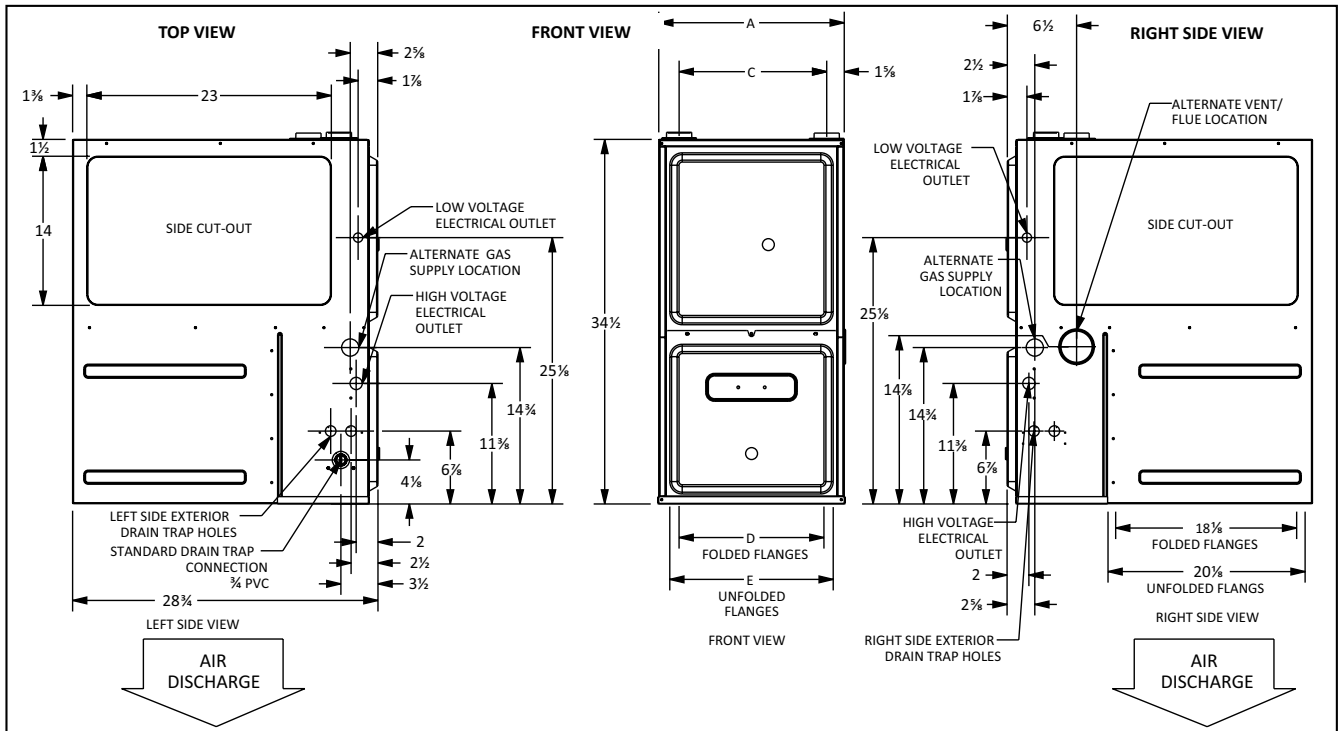

MODEL	A	B	C	D	E
DC96VC0403BNA	17 1/2"	14 5/8"	14"	14 1/2"	16"
DC96VC0603BNA	17 1/2"	14 5/8"	14"	14 1/2"	16"
DC96VC0804CNA	21"	18 5/8"	17 1/2"	18"	19 1/2"
DC96VC1005CNA	21"	18 5/8"	17 1/2"	18"	19 1/2"
DC96VC1205DNA	24 1/2"	21 5/8"	21"	21 1/2"	23"

## MINIMUM CLEARANCES TO COMBUSTIBLE MATERIALS

POSITION	SIDES	REAR	FRONT	BOTTOM	FLUE	TOP
Downflow	0"	0"	3"	NC	0"	1"
Horizontal	6"	0"	3"	C	0"	6"

C = If placed on combustible floor, the floor MUST be wood ONLY.

NC = For installation on non-combustible floors only. A combustible floor sub-base must be used for installations on combustible flooring.

# DC96VC AIRFLOW DATA

**DC96VC0403BNA**  
**COOLING SPEEDS**  
 (@ .1" - .8" w.c. ESP)

TAP	ADJUST	HIGH-STAGE CFM	LOW-STAGE CFM
A	Minus 10%	590	404
	Minus 5%	622	427
	Normal	655	449
	Plus 5%	688	471
	Plus 10%	721	494
B	Minus 10%	726	512
	Minus 5%	767	541
	Normal	807	569
	Plus 5%	847	597
	Plus 10%	888	626
C	Minus 10%	898	644
	Minus 5%	948	680
	Normal	998	716
	Plus 5%	1,048	752
	Plus 10%	1,098	788
D	Minus 10%	1,086	769
	Minus 5%	1,147	811
	Normal	1,207	854
	Plus 5%	1,267	897
	Plus 10%	1,328	939

**DC96VC0403BNA**  
**HEATING SPEED**  
 (@ .1" - .5" w.c. ESP; RISE RANGE: 20 - 50°F)

TAP	ADJUST	HIGH-STAGE CFM	LOW-STAGE CFM	RISE (°F)
A	Minus 10%	861	614	41
	Minus 5%	909	648	39
	Normal	957	682	37
	Plus 5%	1,005	716	35
	Plus 10%	1,053	750	34
B	Minus 10%	953	675	37
	Minus 5%	1,006	713	35
	Normal	1,059	750	34
	Plus 5%	1,112	788	32
	Plus 10%	1,165	825	31
C	Minus 10%	1,040	738	34
	Minus 5%	1,097	779	32
	Normal	1,155	820	31
	Plus 5%	1,213	861	29
	Plus 10%	1,271	902	28
D	Minus 10%	1,126	799	32
	Minus 5%	1,188	844	30
	Normal	1,251	888	28
	Plus 5%	1,314	932	27
	Plus 10%	1,376	977	26

**DC96VC0603BNA**  
**COOLING SPEEDS**  
 (@ .1" - .8" w.c. ESP)

TAP	ADJUST	HIGH-STAGE CFM	LOW-STAGE CFM
A	Minus 10%	590	390
	Minus 5%	623	411
	Normal	656	433
	Plus 5%	689	455
	Plus 10%	722	476
B	Minus 10%	711	487
	Minus 5%	751	514
	Normal	790	541
	Plus 5%	830	568
	Plus 10%	869	595
C	Minus 10%	875	617
	Minus 5%	923	652
	Normal	972	686
	Plus 5%	1,021	720
	Plus 10%	1,069	755
D	Minus 10%	1,076	725
	Minus 5%	1,135	766
	Normal	1,195	806
	Plus 5%	1,255	846
	Plus 10%	1,315	887

**DC96VC0603BNA**  
**HEATING SPEED**  
 (@ .1" - .5" w.c. ESP; RISE RANGE: 35 - 65°F)

TAP	ADJUST	HIGH-STAGE CFM	LOW-STAGE CFM	RISE
A	Minus 10%	844	618	63
	Minus 5%	891	653	60
	Normal	938	687	57
	Plus 5%	985	721	54
	Plus 10%	1,032	756	52
B	Minus 10%	855	676	62
	Minus 5%	903	713	59
	Normal	950	751	56
	Plus 5%	998	789	53
	Plus 10%	1,045	826	51
C	Minus 10%	887	733	60
	Minus 5%	937	773	57
	Normal	986	814	54
	Plus 5%	1,035	855	52
	Plus 10%	1,085	895	49
D	Minus 10%	893	787	60
	Minus 5%	942	830	57
	Normal	992	874	54
	Plus 5%	1,042	918	51
	Plus 10%	1,091	961	49

**NOTES**

- All furnaces ship as high speed for cooling. Installer must adjust blower speed as needed.
- For most jobs, about 400 CFM per ton when cooling is desirable.
- Do not operate above .5" w.c. ESP in heating mode. Operating CFM between .5" and .8" w.c. is tabulated for cooling purposes only.

# DC96VC AIRFLOW DATA (CONT.)

**DC96VC0804CNA**  
**COOLING SPEEDS**  
 (@ .1" - .8" w.c. ESP)

TAP	ADJUST	HIGH-STAGE CFM	LOW-STAGE CFM
A	Minus 10%	753	500
	Minus 5%	795	528
	Normal	837	556
	Plus 5%	879	584
	Plus 10%	921	612
B	Minus 10%	920	643
	Minus 5%	971	678
	Normal	1,022	714
	Plus 5%	1,073	750
	Plus 10%	1,124	785
C	Minus 10%	1,085	754
	Minus 5%	1,146	796
	Normal	1,206	838
	Plus 5%	1,266	880
	Plus 10%	1,327	922
D	Minus 10%	1,328	892
	Minus 5%	1,401	941
	Normal	1,475	991
	Plus 5%	1,549	1,041
	Plus 10%	1,623	1,090

**DC96VC0804CNA**  
**HEATING SPEED**  
 (@ .1" - .5" w.c. ESP; RISE RANGE: 45 - 75°F)

TAP	ADJUST	HIGH-STAGE CFM	LOW-STAGE CFM	RISE
A	Minus 10%	1,111	800	n/a
	Minus 5%	1,172	845	n/a
	Normal	1,234	889	n/a
	Plus 5%	1,296	933	55
	Plus 10%	1,357	978	52
B	Minus 10%	1,193	850	n/a
	Minus 5%	1,259	897	n/a
	Normal	1,325	944	54
	Plus 5%	1,391	991	51
	Plus 10%	1,458	1,038	49
C	Minus 10%	1,298	917	55
	Minus 5%	1,370	968	52
	Normal	1,442	1,019	49
	Plus 5%	1,514	1,070	47
	Plus 10%	1,586	1,121	45
D	Minus 10%	1,375	961	52
	Minus 5%	1,452	1,015	49
	Normal	1,528	1,068	47
	Plus 5%	1,604	1,121	n/a
	Plus 10%	1,681	1,175	n/a

**DC96VC1005CNA**  
**COOLING SPEEDS**  
 (@ .1" - .8" w.c. ESP)

TAP	ADJUST	HIGH-STAGE CFM	LOW-STAGE CFM
A	Minus 10%	706	472
	Minus 5%	745	498
	Normal	784	524
	Plus 5%	823	550
	Plus 10%	862	576
B	Minus 10%	970	670
	Minus 5%	1,024	707
	Normal	1,078	744
	Plus 5%	1,132	781
	Plus 10%	1,186	818
C	Minus 10%	1,249	834
	Minus 5%	1,319	881
	Normal	1,388	927
	Plus 5%	1,457	973
	Plus 10%	1,527	1,020
D	Minus 10%	1,589	1,067
	Minus 5%	1,678	1,126
	Normal	1,766	1,185
	Plus 5%	1,854	1,244
	Plus 10%	1,943	1,304

**DC96VC1005CNA**  
**HEATING SPEED**  
 (@ .1" - .5" w.c. ESP; RISE RANGE: 45 - 75°F)

TAP	ADJUST	HIGH-STAGE CFM	LOW-STAGE CFM	RISE
A	Minus 10%	1,583	1,088	56
	Minus 5%	1,671	1,149	53
	Normal	1,759	1,209	51
	Plus 5%	1,847	1,269	48
	Plus 10%	1,935	1,330	46
B	Minus 10%	1,617	1,124	55
	Minus 5%	1,707	1,187	52
	Normal	1,797	1,249	49
	Plus 5%	1,887	1,311	47
	Plus 10%	1,977	1,374	45
C	Minus 10%	1,656	1,149	54
	Minus 5%	1,748	1,213	51
	Normal	1,840	1,277	48
	Plus 5%	1,932	1,341	46
	Plus 10%	2,024	1,405	44
D	Minus 10%	1,693	1,170	53
	Minus 5%	1,787	1,235	50
	Normal	1,881	1,300	47
	Plus 5%	1,975	1,365	45
	Plus 10%	2,069	1,430	n/a

**NOTES**

- All furnaces ship as high speed for cooling. Installer must adjust blower speed as needed.
- For most jobs, about 400 CFM per ton when cooling is desirable.
- Do not operate above .5" w.c. ESP in heating mode. Operating CFM between .5" and .8" w.c. is tabulated for cooling purposes only.

## DC96VC AIRFLOW DATA (CONT.)

**DC96VC1205DNA  
COOLING SPEEDS  
(@ .1" - .8" w.c. ESP)**

TAP	ADJUST	HIGH-STAGE CFM	LOW-STAGE CFM
A	Minus 10%	769	486
	Minus 5%	811	513
	Normal	854	540
	Plus 5%	897	567
	Plus 10%	939	594
B	Minus 10%	1,011	783
	Minus 5%	1,067	827
	Normal	1,123	870
	Plus 5%	1,179	914
	Plus 10%	1,235	957
C	Minus 10%	1,259	900
	Minus 5%	1,329	950
	Normal	1,399	1,000
	Plus 5%	1,469	1,050
	Plus 10%	1,539	1,100
D	Minus 10%	1,624	1,112
	Minus 5%	1,714	1,173
	Normal	1,804	1,235
	Plus 5%	1,894	1,297
	Plus 10%	1,984	1,359

**DC96VC1205DNA  
HEATING SPEED  
(@ .1" - .5" w.c. ESP; RISE RANGE: 35 - 65°F)**

TAP	ADJUST	HIGH-STAGE CFM	LOW-STAGE CFM	RISE
A	Minus 10%	1,570	1,156	n/a
	Minus 5%	1,657	1,220	64
	Normal	1,744	1,284	61
	Plus 5%	1,831	1,348	58
	Plus 10%	1,918	1,412	56
B	Minus 10%	1,644	1,179	65
	Minus 5%	1,736	1,245	61
	Normal	1,827	1,310	58
	Plus 5%	1,918	1,376	56
	Plus 10%	2,010	1,441	53
C	Minus 10%	1,674	1,215	64
	Minus 5%	1,767	1,283	60
	Normal	1,860	1,350	57
	Plus 5%	1,953	1,418	55
	Plus 10%	2,046	1,485	52
D	Minus 10%	1,726	1,249	62
	Minus 5%	1,822	1,319	59
	Normal	1,918	1,388	56
	Plus 5%	2,014	1,457	53
	Plus 10%	2,110	1,527	51

**NOTES**

- All furnaces ship as high speed for cooling. Installer must adjust blower speed as needed.
- For most jobs, about 400 CFM per ton when cooling is desirable.
- Do not operate above .5" w.c. ESP in heating mode. Operating CFM between .5" and .8" w.c. is tabulated for cooling purposes only.

# TEMPERATURE RISE RANGE CHART

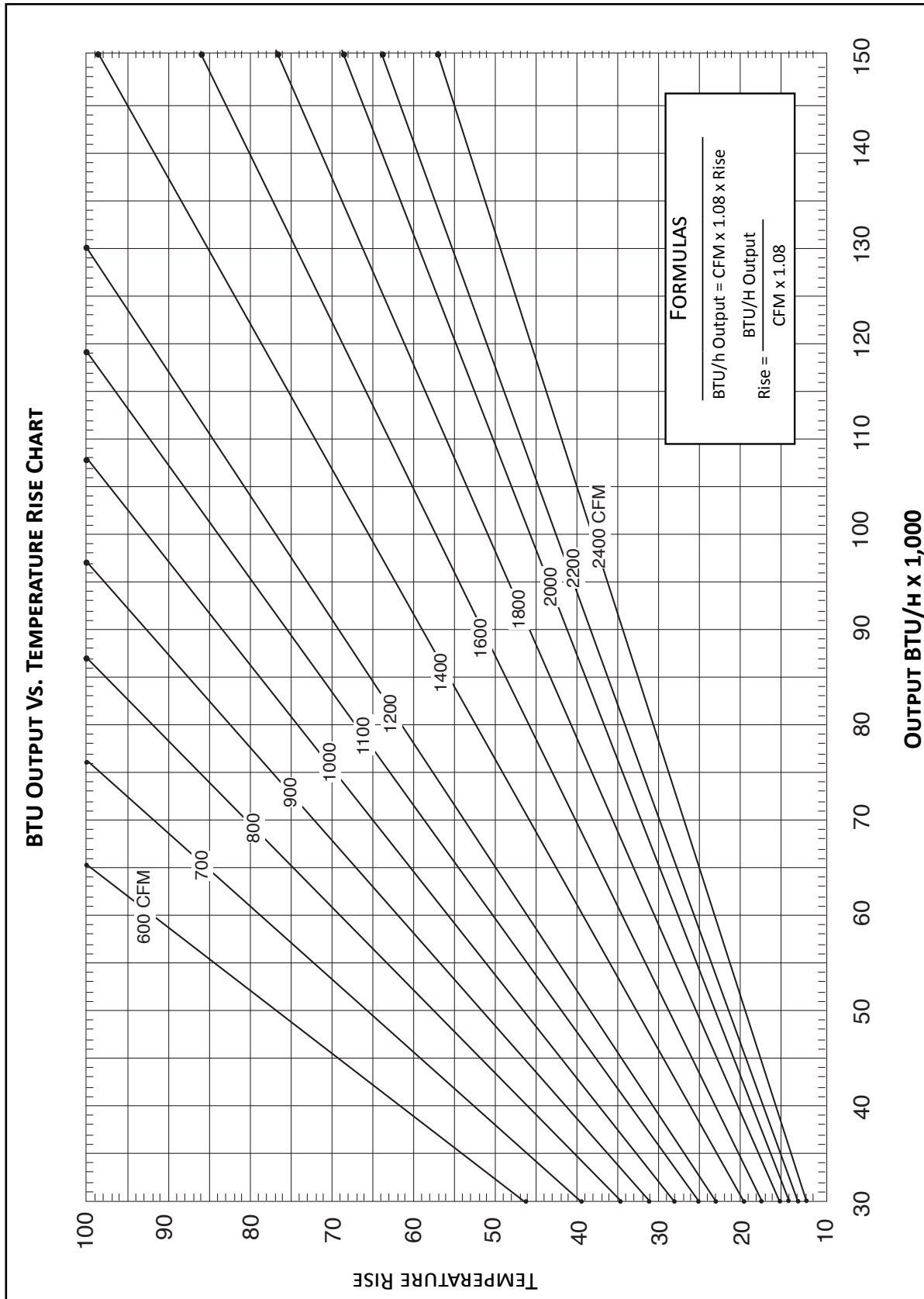



# WIRING DIAGRAM

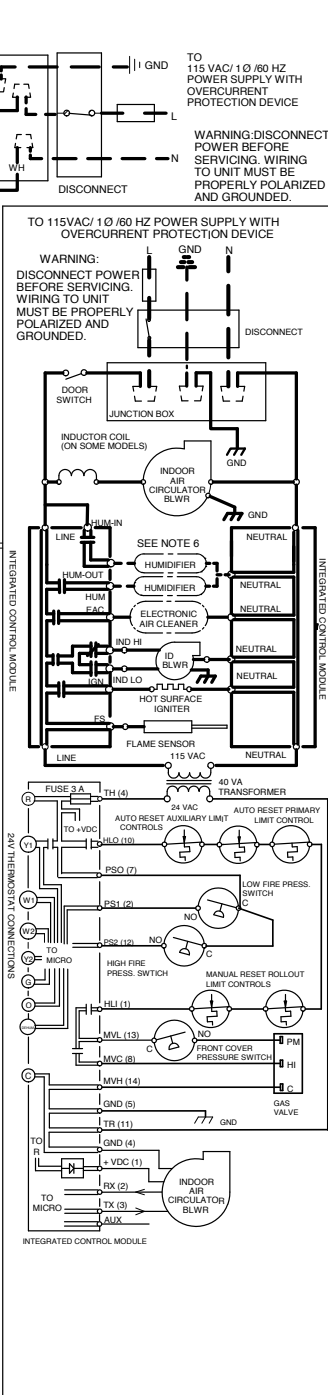
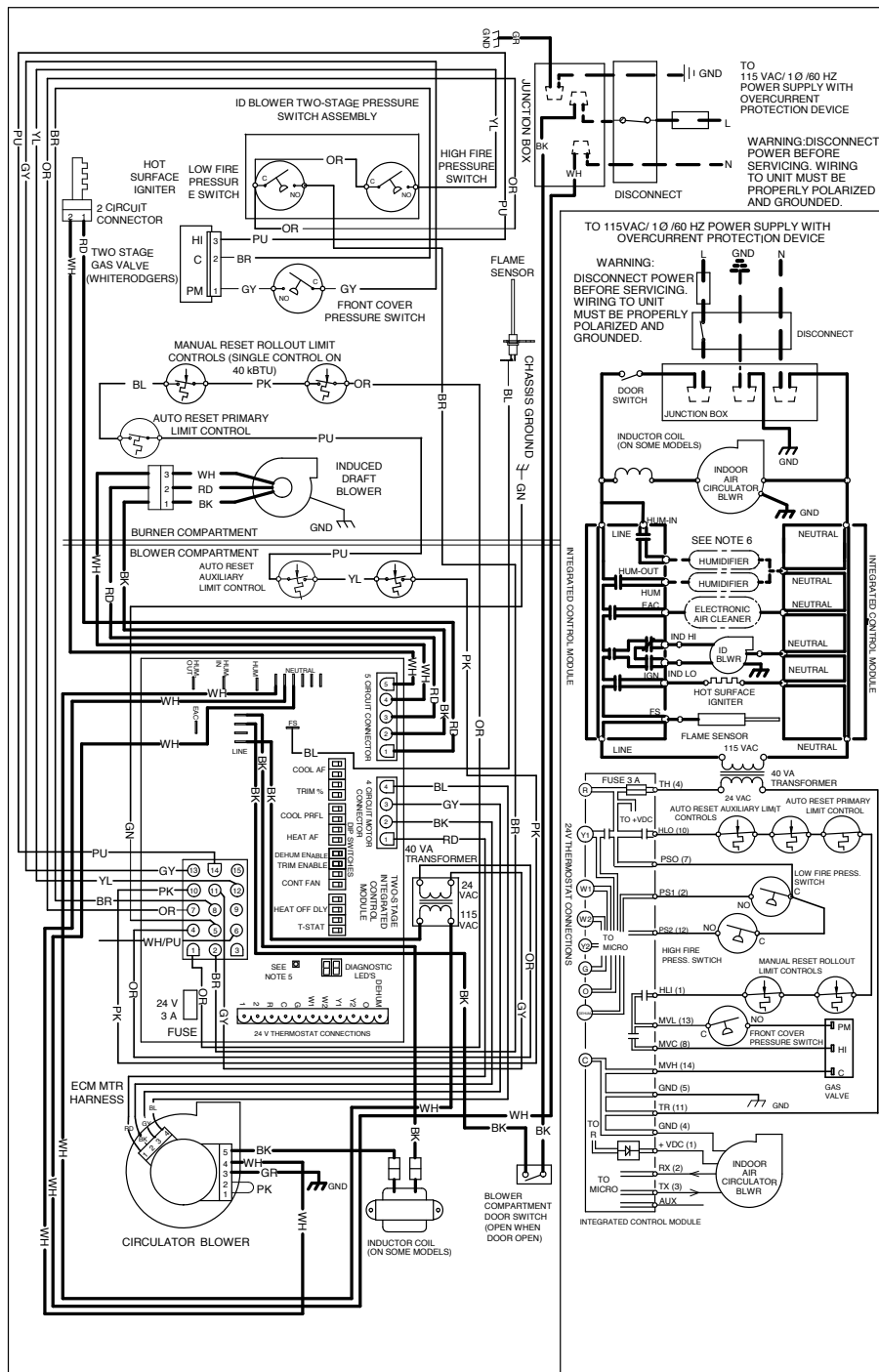

**NOTES:**

1. SET HEAT ANTICIPATOR ON ROOM THERMOSTAT AT 0.7 AMPS.
2. MANUFACTURER'S SPECIFIED REPLACEMENT PARTS MUST BE USED WHEN SERVICING.
3. IF ANY OF THE ORIGINAL WIRE AS SUPPLIED WITH THE FURNACE MUST BE REPLACED, IT MUST BE REPLACED WITH WIRING MATERIAL HAVING A TEMPERATURE RATING OF AT LEAST 105°. USE COPPER CONDUCTORS ONLY.
4. UNIT MUST BE PERMANENTLY GROUNDED AND CONFORM TO N.E.C. AND LOCAL CODES.
5. TO RECALL THE LAST 6 FAULTS, MOST RECENT TO LEAST RECENT, DEPRESS SWITCH FOR MORE THAN 2 SECONDS WHILE IN STANDBY (NO THERMOSTAT INPUTS).
6. HUMIDIFIER INSTALLATION OPTIONS: USE HUM TERMINAL TO RUN HUMIDIFIER DURING HEAT CALL (COMMUNICATING OR LEGACY MODES). USE HUM-IN AND HUM-OUT TERMINALS TO RUN HUMIDIFIER DURING HEAT CALL (COMMUNICATING MODE OR LEGACY MODE) OR INDEPENDENTLY FROM HEAT CALL (COMMUNICATING MODE ONLY - SETUP IS DONE WITHIN COMMUNICATING THERMOSTAT)



0140F02006-A

COLOR CODES:	LOW VOLTAGE (24V)	EQUIPMENT GND
PK PINK	---	
BR BROWN	---	FIELD GND
WH WHITE	---	FIELD SPLICE
BL BLUE	---	SWITCH (TEMP.)
GY GRAY	---	IGNITER
RD RED	---	SWITCH (PRESS.)
YL YELLOW	---	OVERCURRENT PROT. DEVICE
OR ORANGE	---	
PU PURPLE	---	
GN GREEN	---	
BK BLACK	---	

LOW VOLTAGE FIELD	HI VOLTAGE (115V)	HI VOLTAGE FIELD
---	---	---
---	---	---
---	---	---
---	---	---
---	---	---
---	---	---
---	---	---
---	---	---
---	---	---
---	---	---

**High Voltage:** Disconnect all power before servicing or installing this unit. Multiple power sources may be present. Failure to do so may cause property damage, personal injury, or death.

**WARNING**

Wiring is subject to change. Always refer to the wiring diagram on the unit for the most up-to-date wiring.

## ACCESSORIES

MODEL	DESCRIPTION	DC96VC 0403BNA	DC96VC 0603BNA	DC96VC 0804CNA	DC96VC 1005CNA	DC96VC 1205DNA
CVENT-2	Concentric Vent Kit (2")	√	√	√	√	√
CVENT-3	Concentric Vent Kit (3")	√	√	√	√	√
CFSB17	Downflow Sub-Base 17.5"	√	√	---	---	---
CFSB21	Downflow Sub-Base 21"	---	---	√	√	---
CFSB24	Downflow Sub-Base 24"	---	---	---	---	√
RF000142	Drain Kit -Horizontal Left Vertical Flue	---	---	---	---	---
EFR01	External Filter Rack with 16"x25" Permanent Filter	√	√	√	---	---
0170K00000S	Flush Mount Vent Kit - 3" or 2"	√	√	√	√	√
0170K00001S	Flush Mount Vent Kit - 2"	√	√	√	√	√
AFE18-60A	Fossil Fuel (Duel Fuel) Kit	√	√	√	√	√
	High-Altitude Natural Gas Kit	TBD	TBD	TBD	TBD	TBD
	High-Altitude Pressure Switch	TBD	TBD	TBD	TBD	TBD
	High-Altitude LP Gas Kit	TBD	TBD	TBD	TBD	TBD
LPLP03	Low LP Gas Pressure Switch	√	√	√	√	√
LPM-08	LP Conversion Kits	√	√	√	√	√

## THERMOSTATS



CTK04 ComfortNet-compatible Control



CTK02 ComfortNet-compatible Control

## NOTES

## NOTES