

Heating Input: 40,000 – 140,000 BTU/h

TWO-STAGE CONVERTIBLE
MULTI-SPEED GAS FURNACE
80% AFUE

■ Standard Features

- Stainless-steel dual-diameter, tubular heat exchanger
- Two-stage convertible gas valve automatically adjusts to high or low stage
- Durable Silicon Nitride igniter
- Quiet single-speed draft inducer
- Quiet four-speed direct-drive circulating blower motor
- Self-diagnostic control board with constant memory fault code
- Color-coded low-voltage terminals with provisions for electronic air cleaner and humidifier
- Low continuous fan speed options offer quiet air circulation
- California Low NOx emissions standards models available

■ Cabinet Features

- Multi-position installation: upflow, horizontal left or right
- Convenient left or right connection for gas and electrical service
- Cabinet air leakage ($Q_{Leak} \leq 2\%$)
- Heavy-gauge steel cabinet with durable baked-enamel finish
- Fully insulated heat exchanger and blower section

■ Contents

Nomenclature.....	2
Product Specifications.....	3
Dimensions	4
Airflow Data.....	5
Wiring Diagram.....	7
Accessories.....	8



* Complete warranty details available from your local dealer or at www.daikincomfort.com. To receive the Lifetime Heat Exchanger Limited Warranty (good for as long as you own your home) and the 12-Year Parts Limited Warranty, online registration must be completed within 60 days of installation. Online registration is not required in California or Quebec.



NOMENCLATURE

	D	M	80	H	S	40	3	A	X	A	A	
	1	2	3,4	5	6	7,8,9	10	11	12	13	14	
Brand D - Daikin												Minor Revision A - Initial Release B - 1st Revision
Configuration M - Upflow/Horizontal C - Downflow/Horizontal K - Dedicated Upflow D - Dedicated Downflow												Major Revision A - Initial Release B - 1st Revision
AFUE 97 - 97% AFUE 80 - 80% AFUE												NOx N - Natural Gas X - Low NOx
Gas Valve M - Modulating V - 2 Stage H - Convertible 2 Stage S - Single Stage												Cabinet Width A - 14" C - 21" B - 17½" D - 24½"
Motor C - Variable Speed/ComfortNet E - High Efficiency S - Single Speed												Maximum CFM 3 - 1200 CFM 4 - 1600 CFM 5 - 2000 CFM
MBTU/h 040 - 40,000 BTU/h 060 - 60,000 BTU/h 140 - 140,000 BTU/h												

High Voltage: Disconnect all power before servicing or installing this unit. Multiple power sources may be present. Failure to do so may cause property damage, personal injury, or death.



Wiring is subject to change. Always refer to the wiring diagram or the unit for the most up-to-date wiring.

SPECIFICATIONS

	DM80HS 0403A*A	DM80HS 0603A*A	DM80HS 0604B*A	DM80HS 0803B*A	DM80HS 0804B*A	DM80HS 0805C*A	DM80HS 1005C*A	DM80HS 1205D*A	DM80HS 1405D*A
HEATING CAPACITY									
Input ¹	40,000	60,000	60,000	80,000	80,000	80,000	100,000	120,000	140,000
Natural Gas Output ¹	32,000	48,000	48,000	64,000	64,000	64,000	80,000	96,000	112,000
LP Gas Output ¹	32,000	48,000	48,000	64,000	64,000	64,000	80,000	96,000	96,000
AFUE ²	80	80	80	80	80	80	80	80	80
Available AC @ 0.5" ESP	3	3	4	3	4	5	5	5	5
Temperature Rise Range (°F)	25 - 55	20 - 50	20 - 50	35 - 65	35 - 65	35 - 65	35 - 65	40 - 70	40 - 70
CIRCULATOR BLOWER									
Size (D x W)	10" x 6"	10" x 6"	10" x 8"	10" x 8"	10" x 8"	10" x 10"	10" x 10"	11" x 10"	11" x 10"
Horsepower @1075 RPM	⅓	⅓	½	⅓	½	½	½	¾	¾
Available Blower Speeds	4	4	4	4	4	4	4	4	4
Vent Diameter ³	4"	4"	4"	4"	4"	4"	4"	4"	4"
No. of Burners	2	3	3	4	4	4	5	6	6
Disposable Filter (in ²)*	356	610	610	569	569	569	711	776	960
ELECTRICAL DATA									
Min. Circuit Ampacity ⁴	8.1	8.1	12.5	8.1	12.5	12.5	12.5	14.7	14.7
Max. Overcurrent Device (amps) ⁵	15	15	15	15	15	15	15	15	15
SHIP WEIGHT (LBS)									
	86	90	98	106	107	114	118	132	132

¹ Natural Gas BTU/h; for altitudes above from 0' to 5,500' above sea level, reduce input rating 4% for each 1,000' above 5,500' altitude. Low-fire rate is 75% of high-fire rate.

² DOE AFUE based upon Isolated Combustion System (ICS)

³ Vent diameter may vary depending upon vent length. Refer to the latest editions of the National Fuel Gas Code NFPA 54/ANSI Z223.1 (in the USA) and the Canada National Standard of Canada, CAN/CSA B149.1 and CAN/CSA B142.2 (in Canada).

⁴ Minimum Circuit Ampacity = (1.25 x Circulator Blower Amps) + ID Blower amps. Wire size should be determined in accordance with National Electrical Codes. Extensive wire runs will require larger wire sizes.

⁵ Refers to maximum recommended fuse or circuit breaker size. May use fuses or HACR-type circuit breakers of the same size as noted.

* Permanent air filter size is based on 600 FPM velocity. Check with filter manufacturer for specific details.

NOTES

- All furnaces are manufactured for use on 115 VAC, 60 Hz, single-phase electrical supply.
- Gas Service Connection ½" FPT
- Important: Size fuses and wires properly and make electrical connections in accordance with the National Electrical Code and/or all existing local codes.



High Voltage: Disconnect all power before servicing or installing this unit. Multiple power sources may be present. Failure to do so may cause property damage, personal injury, or death.



Wiring is subject to change. Always refer to the wiring diagram or the unit for the most up-to-date wiring.

DIMENSIONS

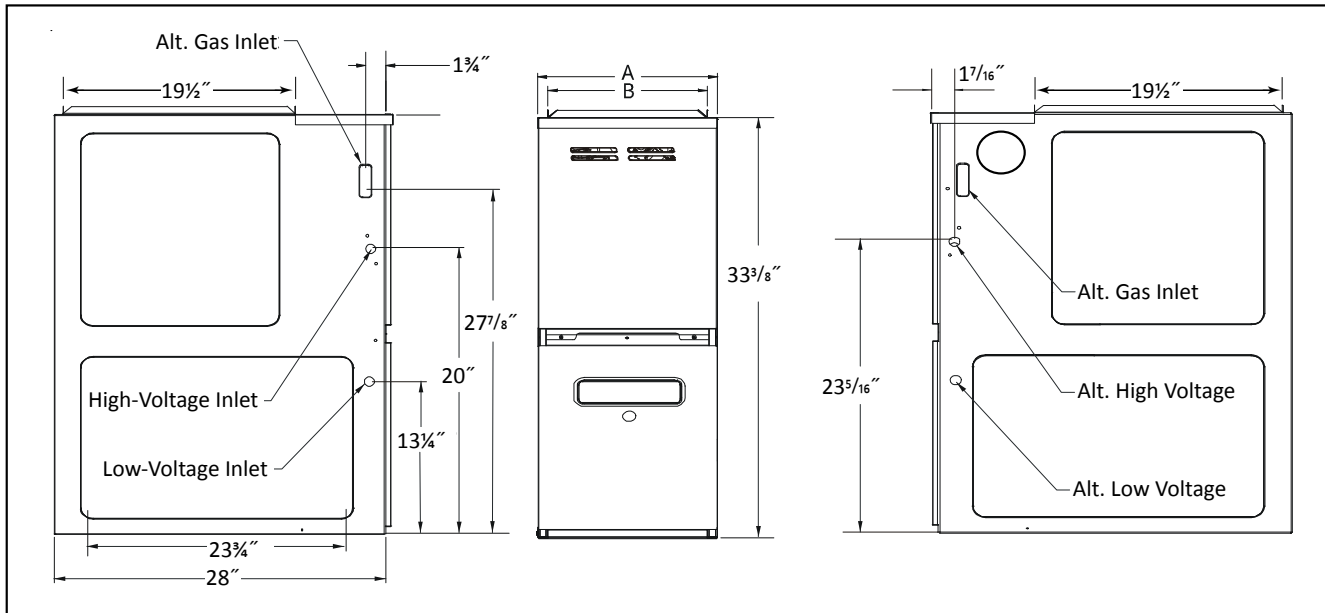

MODEL	A	B
DM80HS0403A*A	14"	12 1/2"
DM80HS0603A*A	14"	12 1/2"
DM80HS0604B*A	17 1/2"	16"
DM80HS0803B*A	17 1/2"	16"
DM80HS0804B*A	17 1/2"	16"

MODEL	A	B
DM80HS0805C*A	21"	19 1/2"
DM80HS1005C*A	21"	19 1/2"
DM80HS1205D*A	24 1/2"	23"
DM80HS1405D*A	24 1/2"	23"

Notes

- Line voltage wiring can enter through the right or left side of furnace.
Low-voltage wiring can enter through the right or left side of furnace.

MINIMUM CLEARANCES TO COMBUSTIBLE MATERIALS

SIDES	REAR	FRONT ¹	VENT ²		TOP
			SW	B	
1"	0"	3"	6"	1"	1"

¹ 24" clearance for serviceability recommended.

² Single Wall Vent (SW) to be used only as a connector. Refer to the latest editions of the National Fuel Gas Code NFPA 54/ ANSI Z223.1 (in the USA) and the Canada National Standard of Canada, CAN/CSA B149.1 and CAN/CSA B142.2 (in Canada).

Note: DM80HS approved for line contact in the horizontal position.

AIRFLOW DATA

(CFM & TEMPERATURE RISE VS. EXTERNAL STATIC PRESSURE)

MODEL (HEATING SPEED AS SHIPPED)	MOTOR SPEED	TONS AC @ 0.5" ESP	EXTERNAL STATIC PRESSURE, (INCHES WATER COLUMN)												
			0.1		0.2		0.3		0.4		0.5		0.6	0.7	0.8
			CFM	RISE	CFM	RISE	CFM	RISE	CFM	RISE	CFM	RISE	CFM	CFM	CFM
DM80HS 0403A*A	High	3	1,521	---	1,466	---	1,414	---	1,373	---	1,298	---	1,243	1,164	1,075
	Med	2.5	1,160	26	1,160	26	1,132	26	1,121	26	1,082	27	1,042	997	925
	Med-Lo	2	961	31	955	31	948	31	932	32	913	33	882	821	803
	Low	1.5	781	38	785	38	781	38	773	38	761	32	745	716	668
DM80HS 0603A*A	High	3	1,422	31	1,352	33	1,307	34	1,197	37	1,157	38	1,092	1,075	983
	Med	2.5	1,098	40	1,081	41	1,051	42	1,039	43	1,021	44	983	924	868
	Med-Lo	2	919	48	913	49	892	50	847	---	829	---	818	792	728
	Low	1.5	758	---	741	---	741	---	733	---	699	---	677	649	626
DM80HS 0604B*A	High	4	2,134	21	2,100	21	2,042	22	1,975	23	1,883	24	1,786	1,700	1,601
	Med	3.5	1,668	27	1,663	27	1,656	27	1,645	27	1,616	28	1,549	1,492	1,391
	Med-Lo	3	1,419	31	1,426	31	1,426	31	1,432	31	1,419	31	1,378	1,328	1,261
	Low	2.5	1,134	39	1,145	39	1,166	38	1,171	38	1,160	38	1,144	1,111	1,071
DM80HS 0803B*A	High	3	1,607	37	1,572	38	1,547	39	1,498	40	1,448	41	1,390	1,302	1,222
	Med	2.5	1,159	51	1,156	51	1,145	52	1,127	53	1,108	53	1,075	1,033	957
	Med-Lo	2	938	63	916	65	916	65	900	---	889	---	865	829	785
	Low	1.5	785	---	766	---	743	---	730	---	709	---	683	666	604
DM80HS 0804B*A	High	4	2,051	---	1,983	---	1,895	---	1,812	---	1,725	---	1,627	1,530	1,439
	Med	3.5	1,736	---	1,708	35	1,652	36	1,611	37	1,540	38	1,475	1,394	1,307
	Med-Lo	3	1,493	35	1,668	36	1,459	41	1,429	41	1,389	43	1,339	1,274	1,204
	Low	2.5	1,200	49	1,185	50	1,180	50	1,173	51	1,158	51	1,125	1,125	1,080
DM80HS 0805C*A	High	5	2,290	---	2,229	---	2,155	---	2,047	---	1,960	---	1,837	1,712	1,584
	Med	4	1,852	---	1,820	---	1,777	---	1,719	---	1,641	36	1,567	1,469	1,382
	Med-Lo	3.5	1,615	37	1,592	37	1,556	38	1,516	39	1,470	40	1,405	1,346	1,235
	Low	3	1,290	46	1,285	46	1,265	47	1,235	48	1,214	49	1,174	1,044	904
DM80HS 1005C*A	High	5	2,323	---	2,225	---	2,120	35	2,040	36	1,974	38	1,801	1,688	1,577
	Med	4	1,858	40	1,847	40	1,799	41	1,744	42	1,674	44	1,577	1,493	1,399
	Med-Lo	3.5	1,596	46	1,587	47	1,571	47	1,552	48	1,493	50	1,397	1,326	1,217
	Low	3	1,291	57	1,272	58	1,261	59	1,257	59	1,205	61	1,168	1,118	1,060
DM80HS 1205D*A	High	5	2,469	---	2,389	---	2,300	---	2,223	40	2,131	42	2,027	1,902	1,786
	Med	4	1,575	56	1,558	57	1,545	58	1,513	59	1,500	59	1,419	1,354	1,271
	Med-Lo	3.5	1,402	63	1,380	64	1,343	66	1,319	67	1,296	69	1,245	1,183	1,106
	Low	3	1,200	---	1,186	---	1,161	---	1,127	---	1,082	---	1,042	995	926
DM80HS 1405D*A	High	5	2,469	---	2,389	---	2,300	---	2,223	40	2,131	42	2,027	1,902	1,786
	Med	4	1,575	56	1,558	57	1,545	58	1,513	59	1,500	59	1,419	1,354	1,271
	Med-Lo	3.5	1,402	63	1,380	64	1,343	66	1,319	67	1,296	69	1,245	1,183	1,106
	Low	3	1,200	---	1,186	---	1,161	---	1,127	---	1,082	---	1,042	995	926

Notes

- CFM in chart is without filter(s). Filters do not ship with this furnace, but must be provided by the installer. If the furnace requires two return filters, this chart assumes both filters are installed.
- All furnaces ship as high-speed cooling and medium-speed heating. Installer must adjust blower cooling and heating speed as needed.
- For most jobs, 400 CFM per ton for cooling is desirable.
- INSTALLATION IS TO BE ADJUSTED TO OBTAIN TEMPERATURE RISE WITHIN THE RANGE SPECIFIED ON THE RATING PLATE.
- This chart is for information only. For satisfactory operation, external static pressure should not exceed value shown on the rating plate.
- The dashed (---) areas indicate a temperature rise not recommended for this model.
- At higher altitudes, a properly derated unit will have approximately the same temperature rise at a particular CFM, while ESP at the CFM will be lower.

TEMPERATURE RISE RANGE CHART

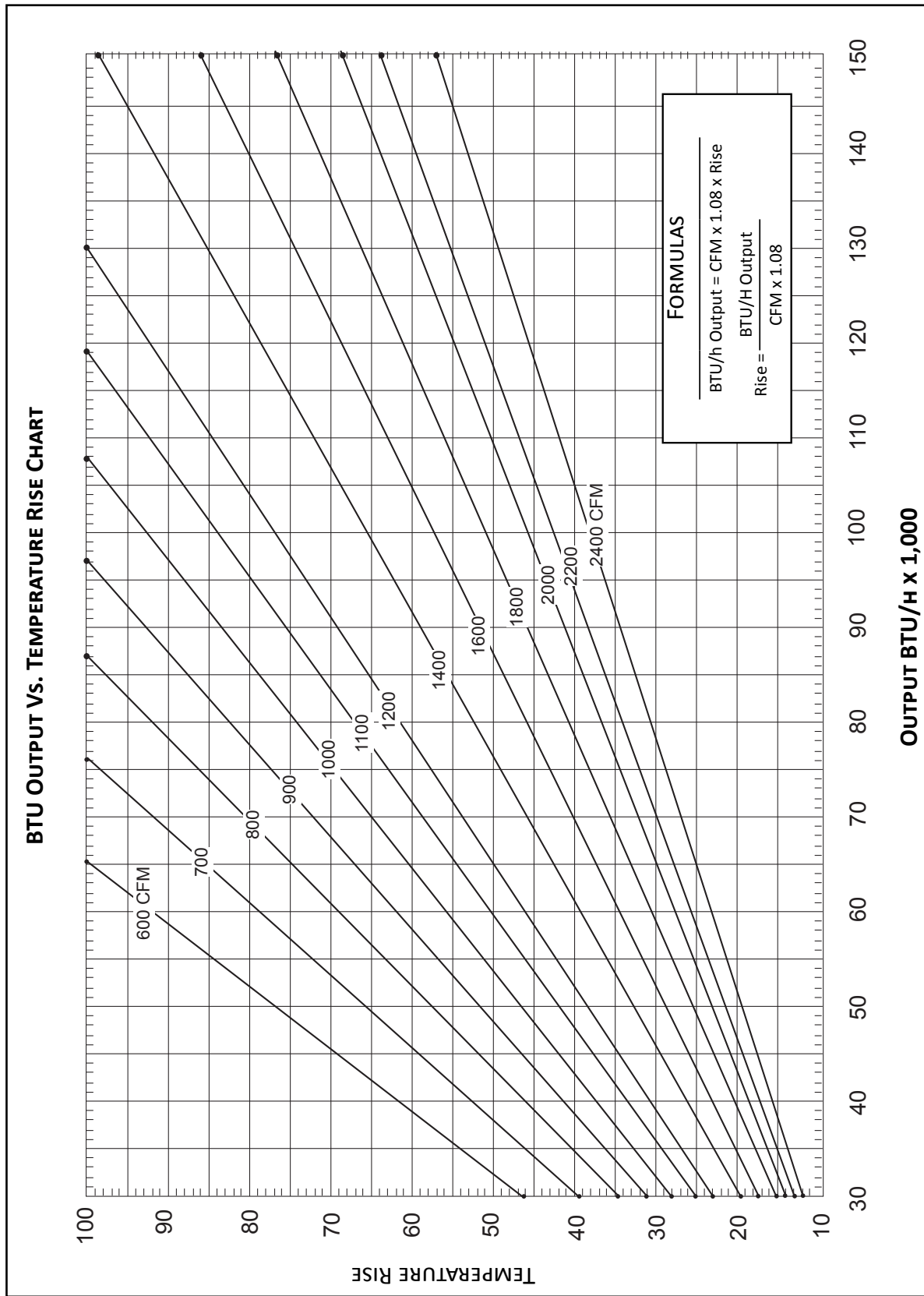

Wiring is subject to change. Always refer to the wiring diagram or the unit for the most up-to-date wiring.



WARNING

High Voltage: Disconnect all power before servicing or installing this unit. Multiple power sources may be present. Failure to do so may cause property damage, personal injury, or death.



ACCESSORIES

MODEL	DESCRIPTION
LPM-06 ¹	LP Conversion Kit (Springs & Orifice)
HANG21	High-Altitude Natural Gas Kit (5500+ ft)
MVK-01 ²	Masonry Vent Kit
MVK-02 ²	Masonry Vent Kit (for DM80HS1205D and DM80HS1405D models only)
AFE18-60A	Fossil Fuel Kit
FTK04	Twinning Kit

¹ White-Rodgers and Honeywell valves

² Upflow applications only