



# Daikin iTouch Controller Install & Commissioning

## Participant Guide



COMFORT FOR LIFE

## iTouch Controller Install and Commissioning



# iTouch Controller – DCS601C71

## Product Features



## iTouch Controller



### Equipment Dimensions

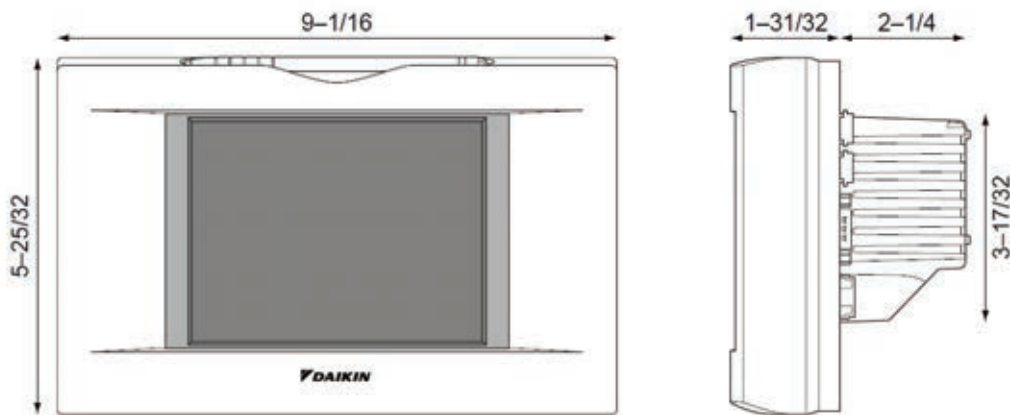

## Intelligent Touch Controller Specifications

Power	AC24V 50/60Hz
Power consumption	10 W maximum <span style="color: red;">(20VA transformer)</span>
Force stop input	Normally-open contact Contact current approximately 10 mA
Size	9-1/16 × 5-25/32 × 4-7/32 (W × H × D)
Mass	2 lb 10 oz

## iTouch Controller

### Specifications

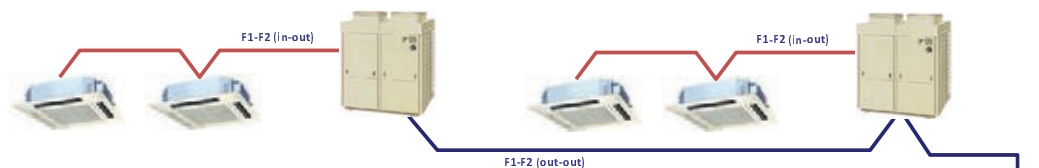

#### Input terminals:

Digital input DI x 1

forced shutdown indoor units  
(10mA maximum input current)

Pulse input PI x 3 (for PPD option)

1 pulse at 1 or  
10 kWh over 100 ms

Certifications:

FCC Part 15 Subpart B Class A

Interference (EMC)

#### Standard Features:

- One year warranty

SPECIFICATIONS OF COMMUNICATIONS CABLING (DIII-NET)	
<b>TYPE</b>	2-conductor, stranded, non-shielded copper cable / PVC or vinyl jacket
<b>SIZE</b>	AWG18-2
<b>TOTAL LENGTH</b>	Maximum wiring distance between units: 3,280 ft Maximum wiring length: 6,550 ft



DCS601C/1

# iTouch Controller



## intelligent Touch Controller (iTouch) V6 (DCS601C71)



- Advanced Zone Level Control
  - Add advanced temperature control functions from a zone controller
- Independent Cool, Heat, and Setback Setpoints
  - Configurable Occupied/Unoccupied Setpoint Ranges (60°F - 90°F / 40°F - 95°F)
  - Adjustable recovery differential
- Automatic Changeover in Heat Pump and Heat Recovery Systems
  - At 2.7°F above Cooling and 2.7°F below Heating setpoints
- Weekly Schedule
  - 7, 5+2, 5+1+1 Week Patterns
    - 8 schedule patterns with 8 scheduled actions per day
  - Annual Schedule
    - 40 exception days to (repeats yearly)
- Backwards Compatible
- SMTP-AUTH authentication for more security
- Forced ON/OFF

# iTouch Controller



## Expanded Capabilities

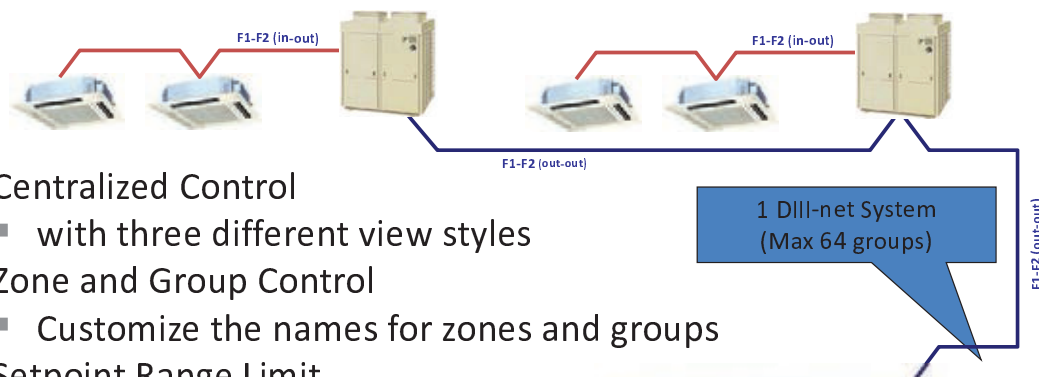

- Centralized Control
  - with three different view styles
- Zone and Group Control
  - Customize the names for zones and groups
- Setpoint Range Limit
- Simple interlock
- Web server (option)
- Alarm E-mail (option)
- PPD (tenant billing option)
- HTTP interface (option) -



Touch screen

# intelligent Touch Controller



- Doubles the connected equipment capacity of the iTouch Controller

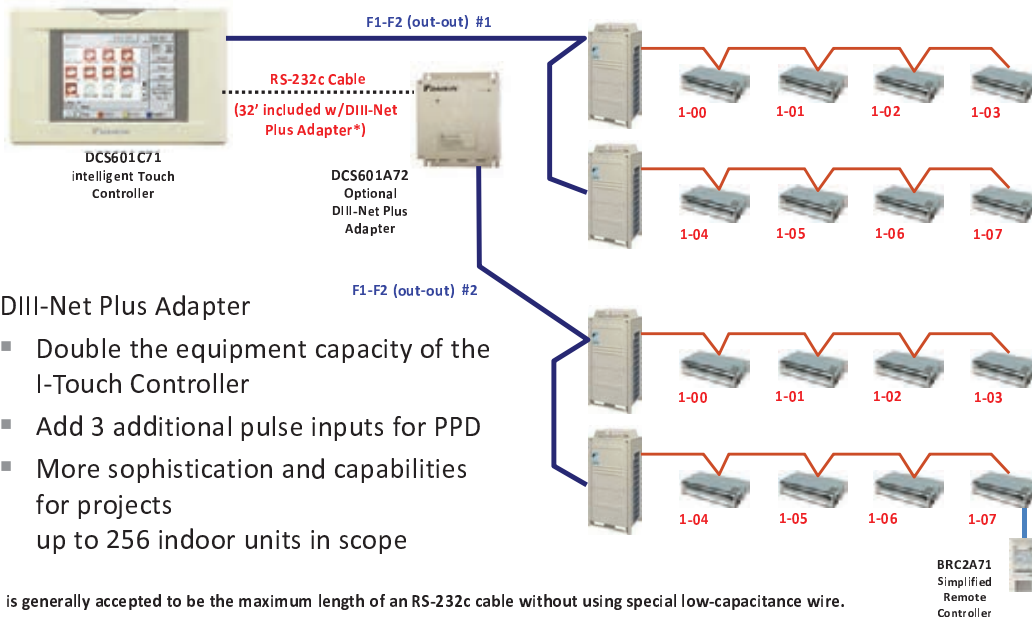

- DIII-Net Plus Adapter
  - Double the equipment capacity of the I-Touch Controller
  - Add 3 additional pulse inputs for PPD
  - More sophistication and capabilities for projects up to 256 indoor units in scope

\*50' is generally accepted to be the maximum length of an RS-232c cable without using special low-capacitance wire.

# Commercial Application



## Ancillary Device Control

- Digital input / output adapters for two-position monitoring and control
- Manage lights, circulation pumps, ventilation fans, and dampers
- Manual control, scheduled events, and simple interlocks
- Alarm inputs for remote notification of abnormal conditions

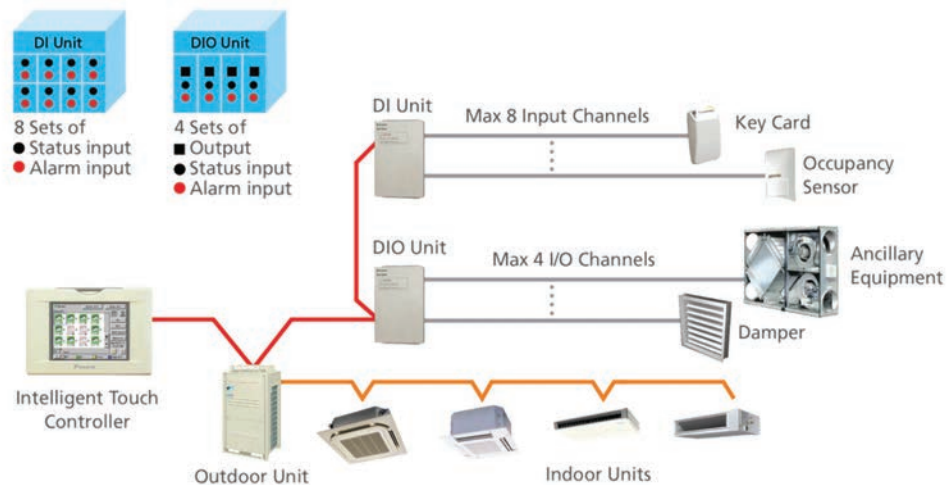

# Power Proportional Distribution



- PPD Concept and Technology
  - Based on calculated demand from each indoor unit
  - Utilizes variables including suction air temperature and EEV pulses
  - Mathematically calculated based on indoor unit coefficient
  - Operating pressures, temperatures and piping length affect overall accuracy
  - Daikin does not predict PPD accuracy due to field conditions and installation

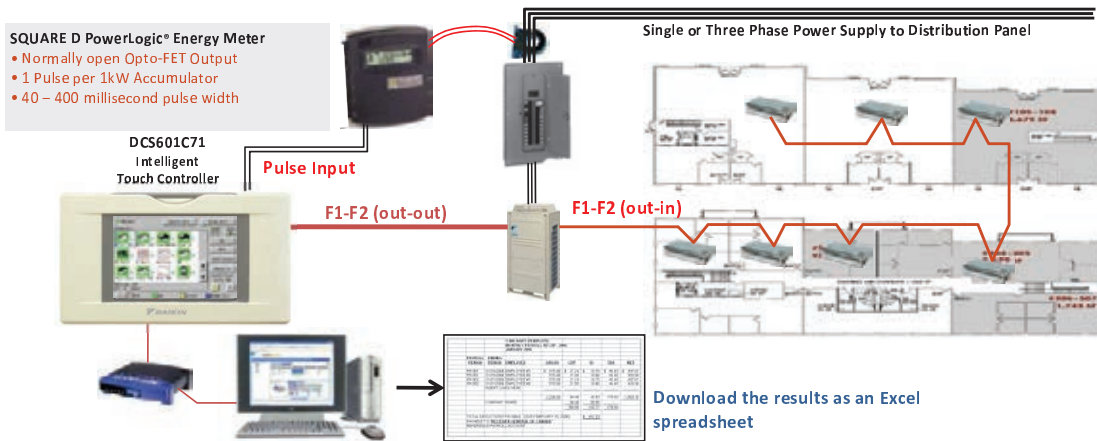

## Section 2

### Wiring



# iTouch Controller



## Electrical Connections

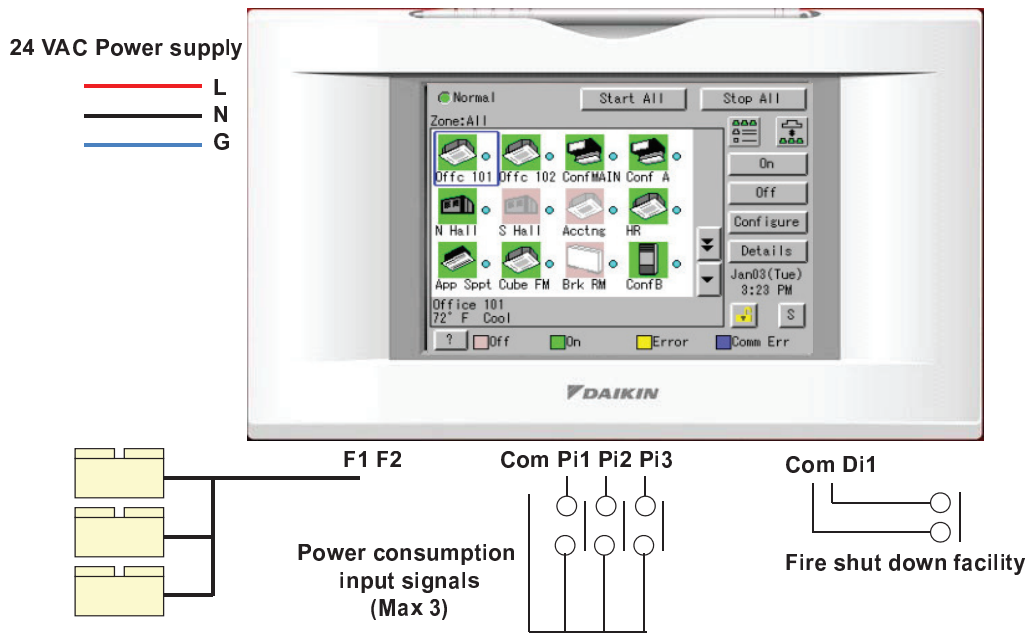

# iTouch Controller



## Electrical Connections - Back

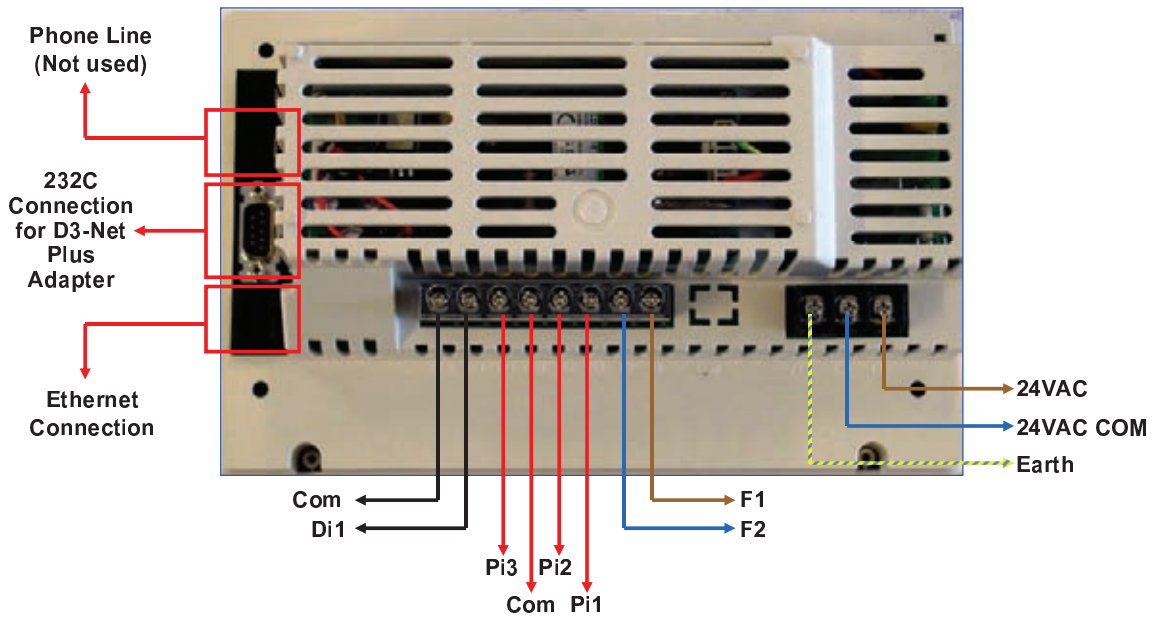



# iTouch Controller



## External Adjustments

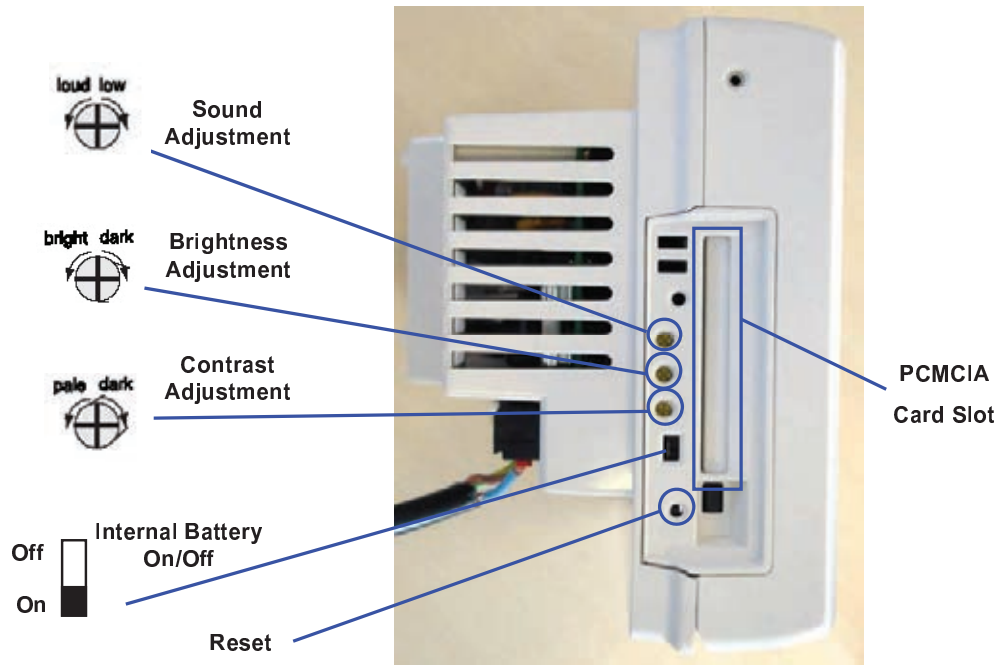

# iTouch Controller



## Combination Allowances



	Central Controller	Unified On/Off	Schedule Timer	iTouch Controller	iTouch Manager	BACnet Interface	LON Interface
Central Controller	OK	OK	OK	OK	OK	OK	OK
Unified On/Off	OK	OK	OK	OK	OK	OK	OK
Schedule Timer	OK	OK	NO	NO	NO	NO	NO
iTouch Controller	OK	OK	NO	NO	NO	OK	OK
iTouch Manager	OK	OK	NO	NO	NO	OK	OK
BACnet Interface	OK	OK	NO	OK	OK	NO	NO
LON Interface	OK	OK	NO	OK	OK	NO	NO

# Configuring the Program



## Applying Power



### Ensure That The Internal Battery Is Switched On

Internal Battery  
On/Off

Off

On



### Version Upgrade to V6.04

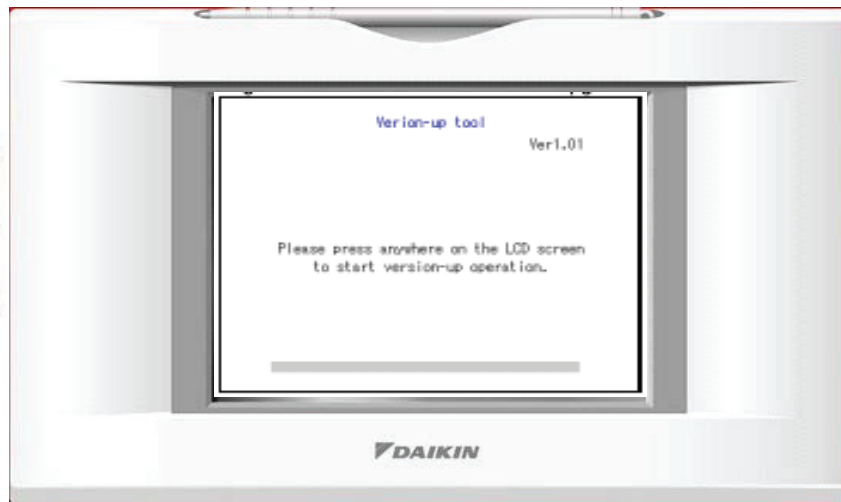

## Version Upgrade to V6.04

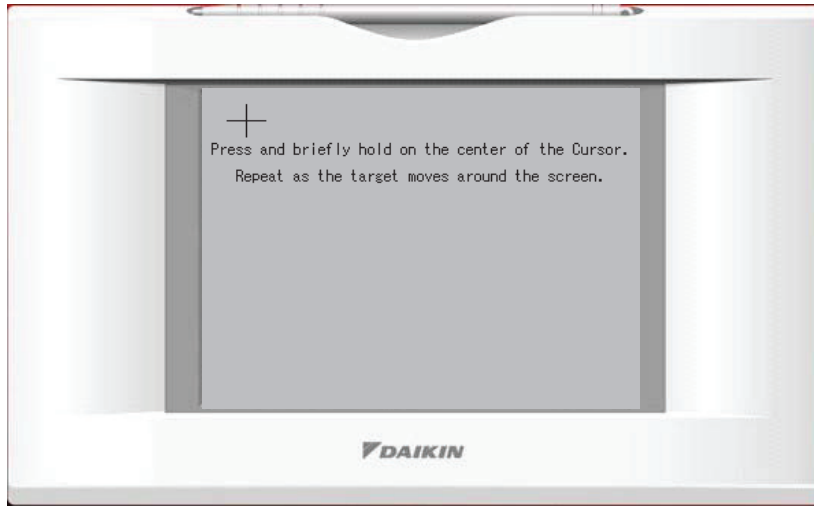

## Version Upgrade to V6.04



## Version Upgrade to V6.04



**After completed, remove the PCMCIA card and Restart**

## Select The Language Setting



## Select A Time Zone And Daylight Saving Hours

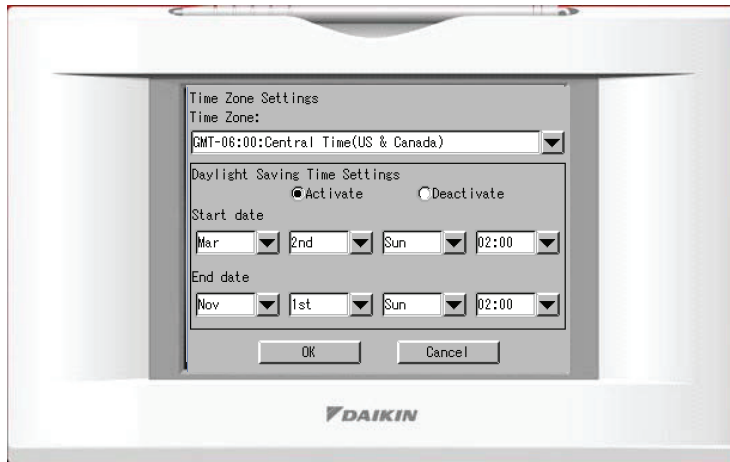

From the second Sunday in March to the first Sunday in November

<http://www.infoplease.com/spot/daylight1.html>

## Input Activation Key To Activate Basic Software

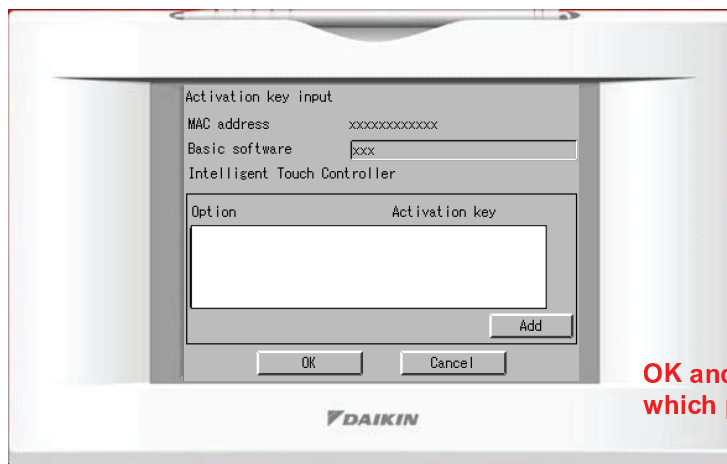

OK and a screen which presses reboot

Each ITC has a unique activation key that must be entered upon start-up in order to activate the basic software. To obtain this activation key, you must call your local Daikin AC Technical Support and quote both the “Software ID number” and the “Mac Address” of your ITC, plus some site information – such as amount of units being controlled.

## DIII Plus Adapter Setting



**Check Enabled when D3 Plus Adapter exists**

## DIII-NET Engineering

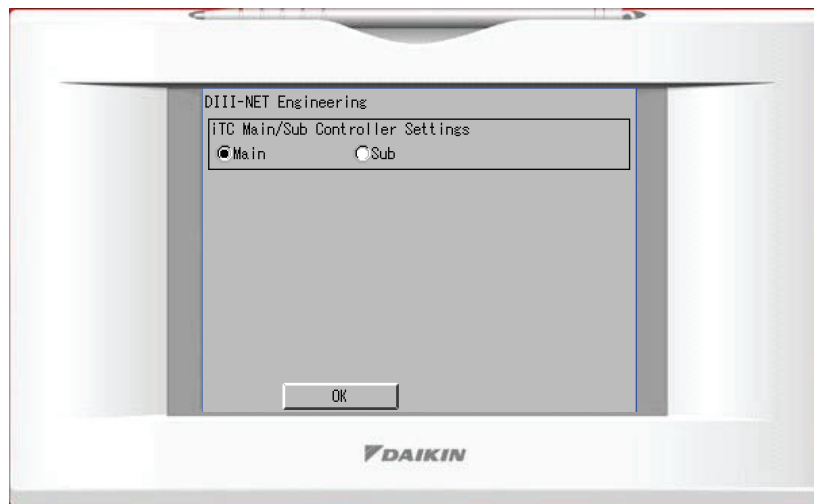

**Group address can be assigned after a Main iTouch Controller exists in the D3-Net line**

**When two iTouch Controllers are connected to the same D3-Net line, one of the controllers must be made in to a sub controller**

## Programming the Group Address



### BRC1E71/72

- When a multi zone controller is connected, group address setting is available in Service Settings
- Push any key to activate backlight
- Hold Cancel button for 4 seconds to enter Service Settings Menu

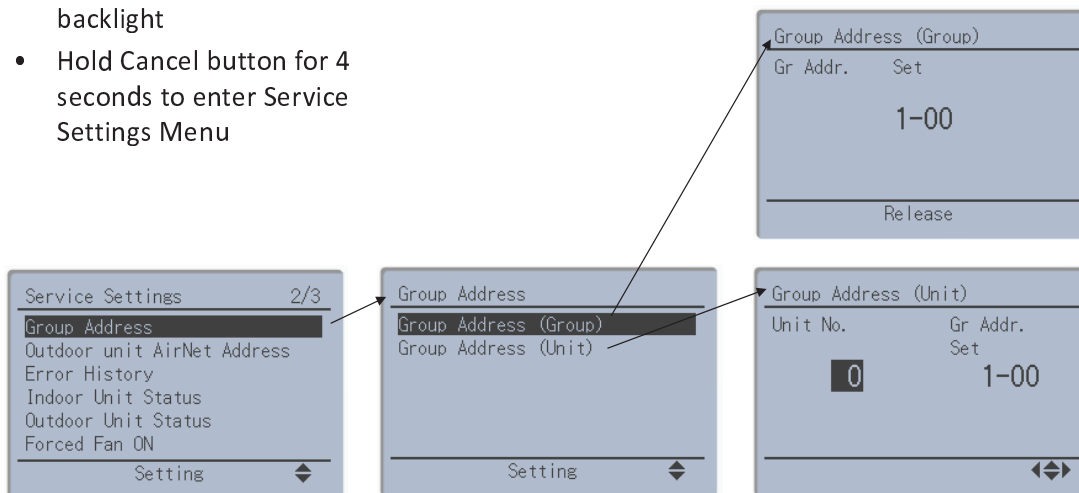

## Programming the Group Address



### BRC2A71

Open the cover of the controller and you can see the setting switches of BS 6 to 10

#### ■ Simplified remote controller

- Group No. setting by simplified remote controller.
1. Remove the cover of remote controller.
  2. While in normal mode, press the [BS6] BUTTON (field set) to enter the FIELD SET MODE.
  3. Select the mode No. [00] with [BS2] BUTTON (temperature setting ▲) and [BS3] BUTTON (temperature setting ▼).
  4. Select the group No. with [BS9] BUTTON (set A) and [BS10] BUTTON (set B). (Group Nos. increase in the order of 1-00, 1-01.....1-15, 2-00,.....4-15. However, the unified ON/OFF controller displays only group No. set within the range of control.)
  5. Press [BS7] BUTTON (set/cancel) to set group No.
  6. Press [BS6] BUTTON (field set) to return to the NORMAL MODE.

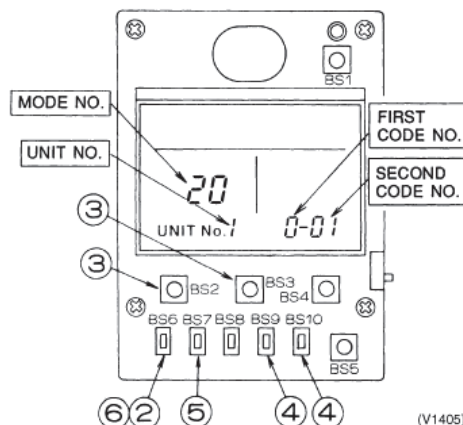



# Programming the Group Address



## BRC1D71

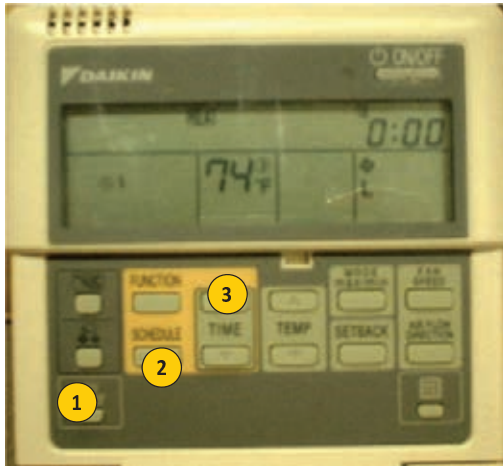

When applying a Daikin “Multizone Controller” such as an iTouch Controller, iManager or Centralized Controller to the VRV system, indoor unit group addressing must be done manually. This establishes each groups identity. This programming is accomplished utilizing the Daikin remote controller.

1. Press and hold the **TEST** (1) button for 5 seconds to enter the programming mode.
2. Display should indicate mode **00** with the current group assignment as **1-01**.
3. The word **“GROUP”** should be flashing. If not, press the **SCHEDULE** (2) button.
4. Using the **TIME** (3) buttons, set the desired address.
5. Once the desired address has been set, press the **SCHEDULE** (2) button to confirm the new address.
6. Press the **TEST** (1) button to exit programming mode.



## Control Point Registration

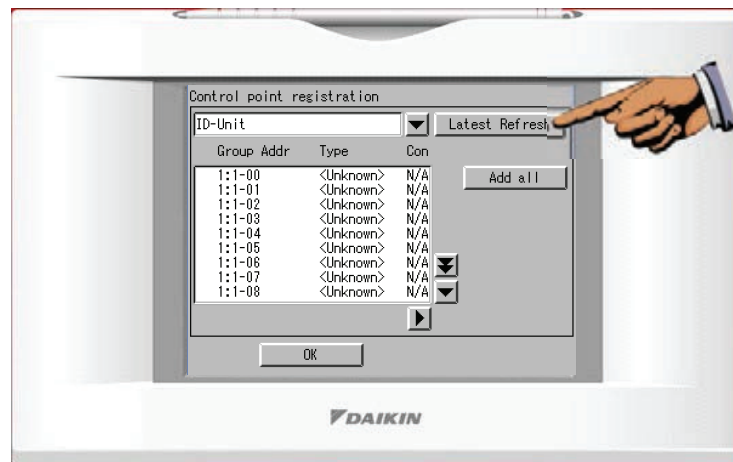

### Control Point Registration

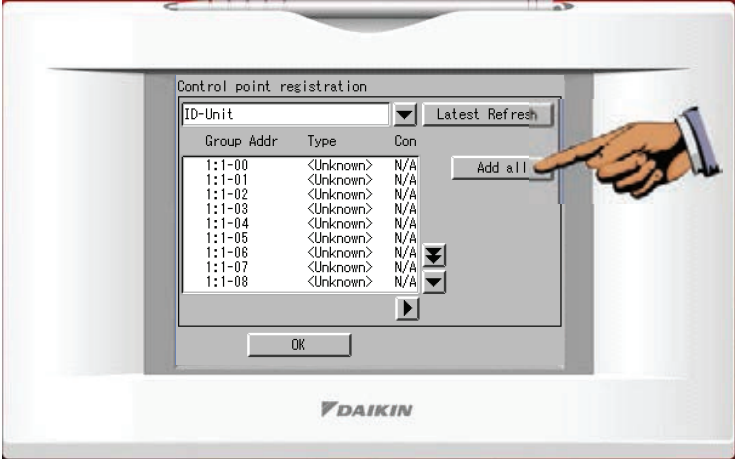

### Control Point Registration



### Control Point Registration

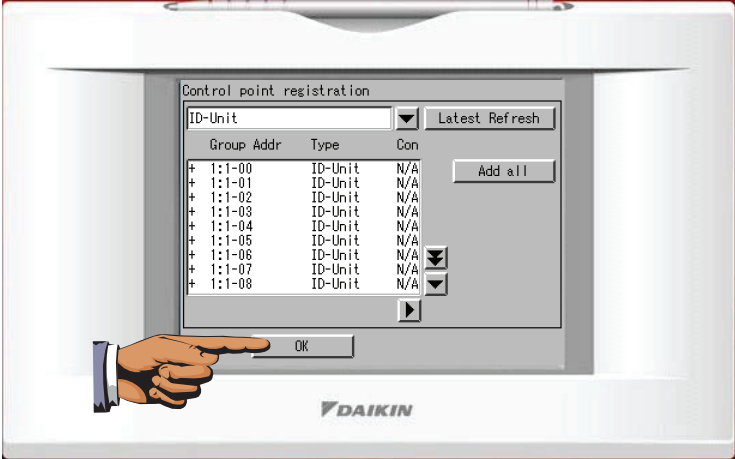

### Control Point Registration

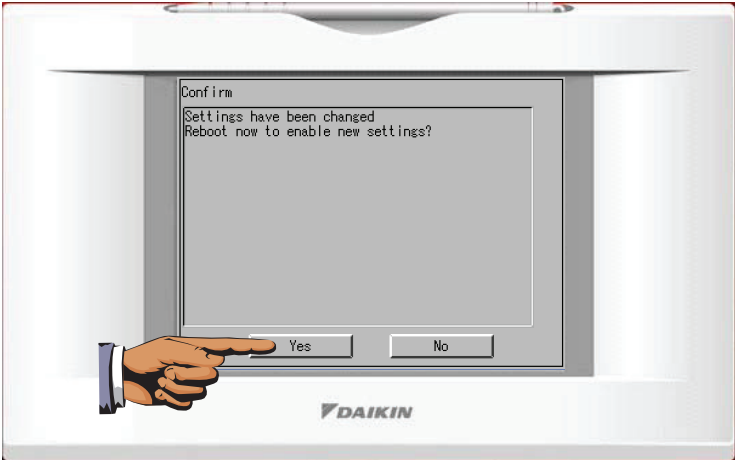

## Configuration of the Setting Modes

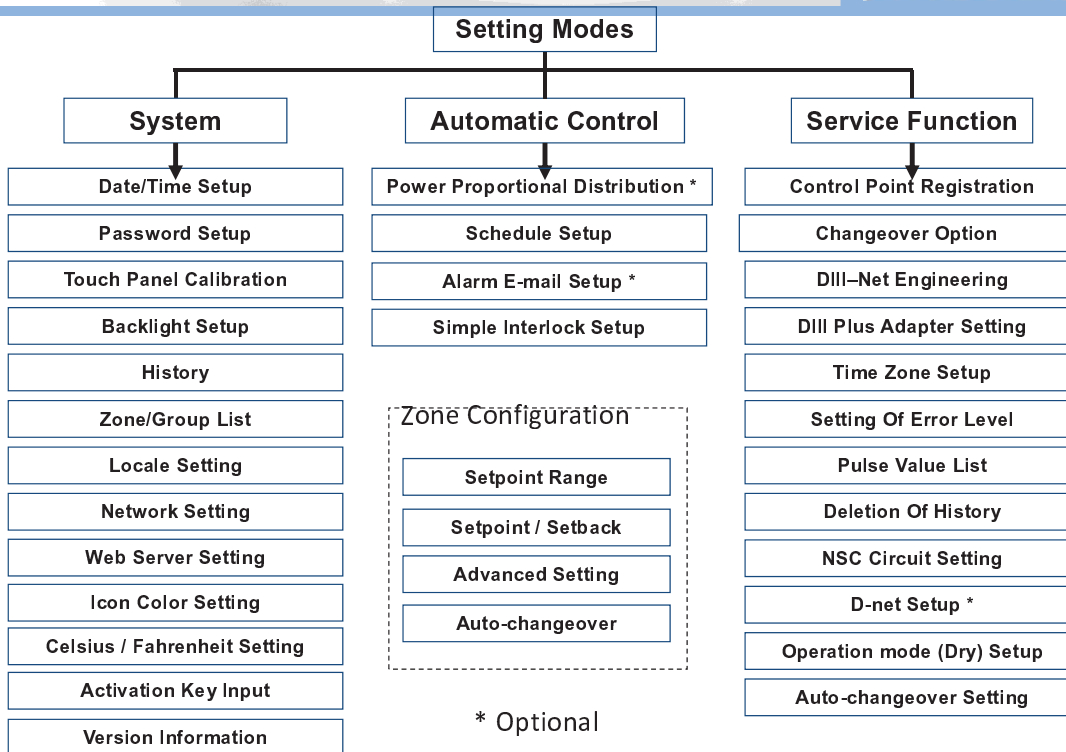

# Setting Modes

## “System Category”

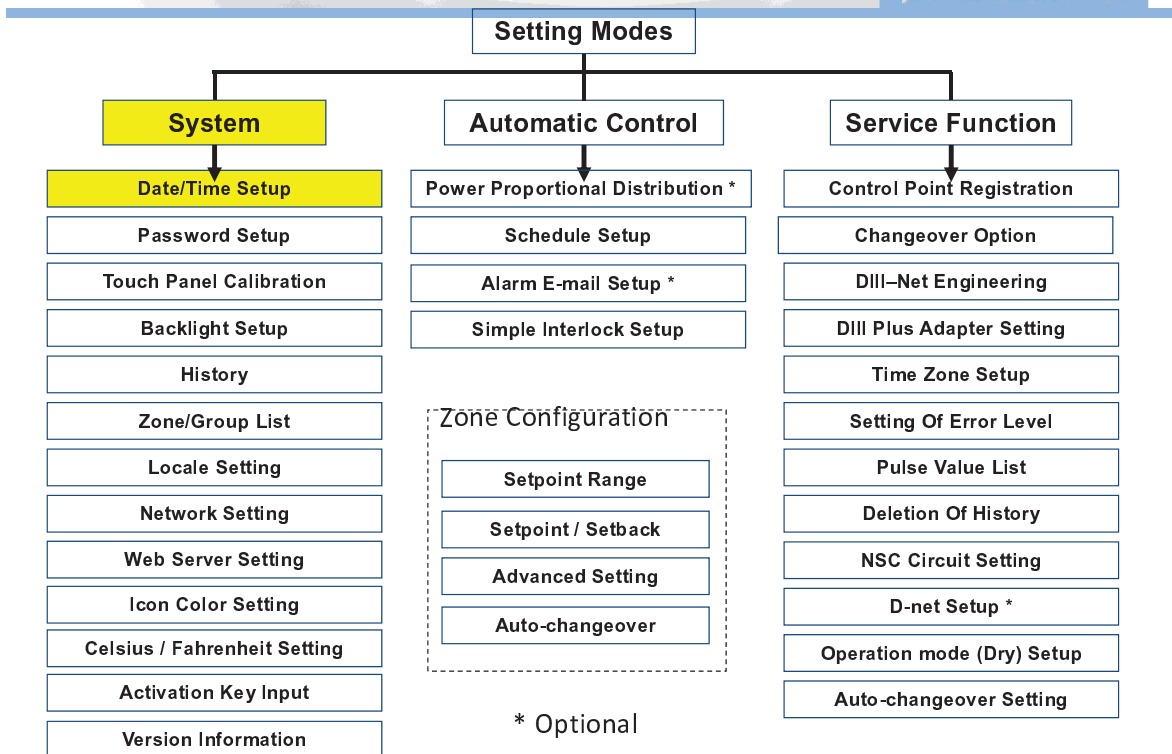

## Date and Time Setup



## Date and Time Setup

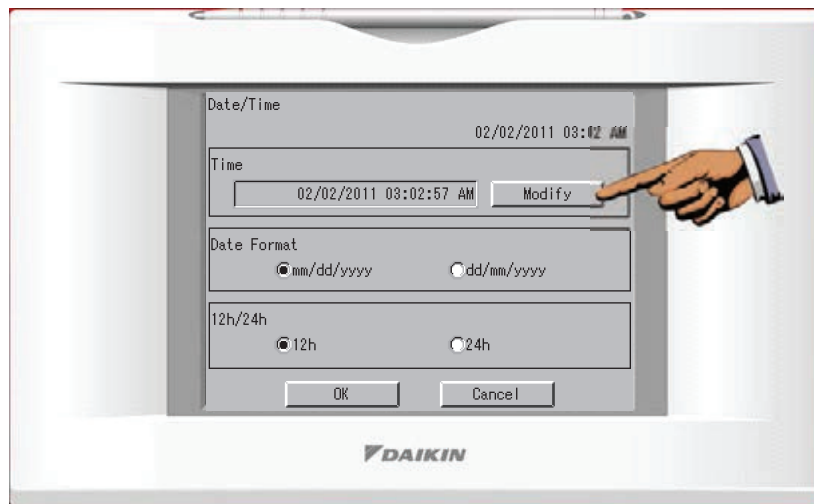

## Date and Time Setup

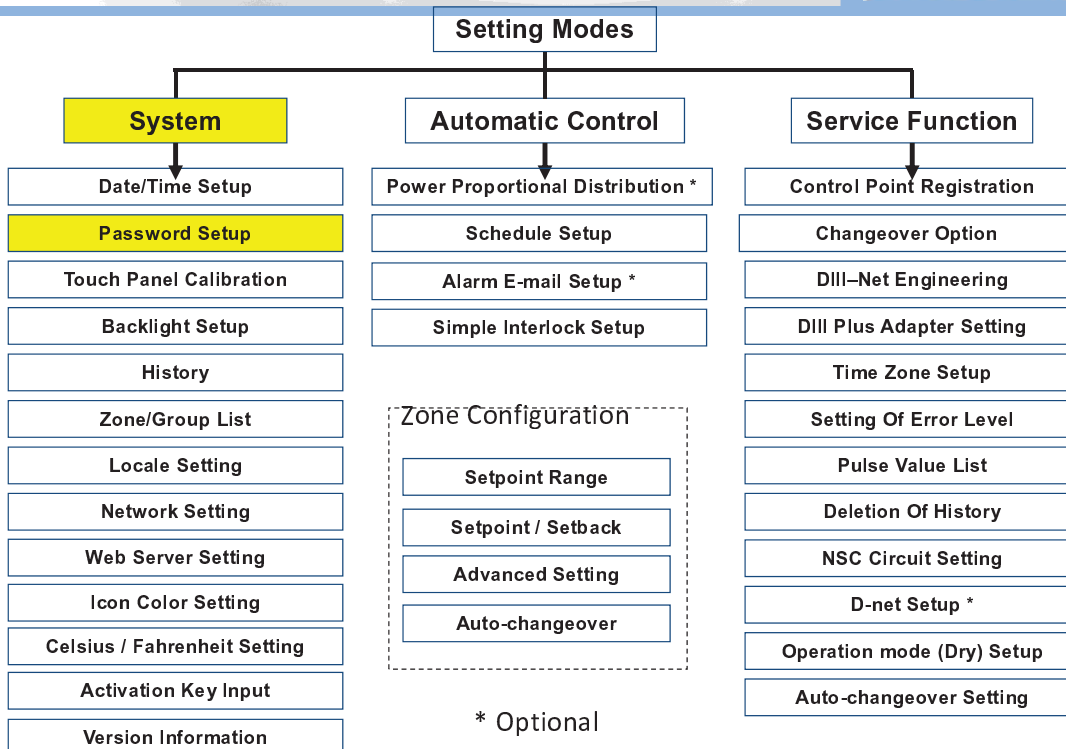

## Password Setup



## Password Setup

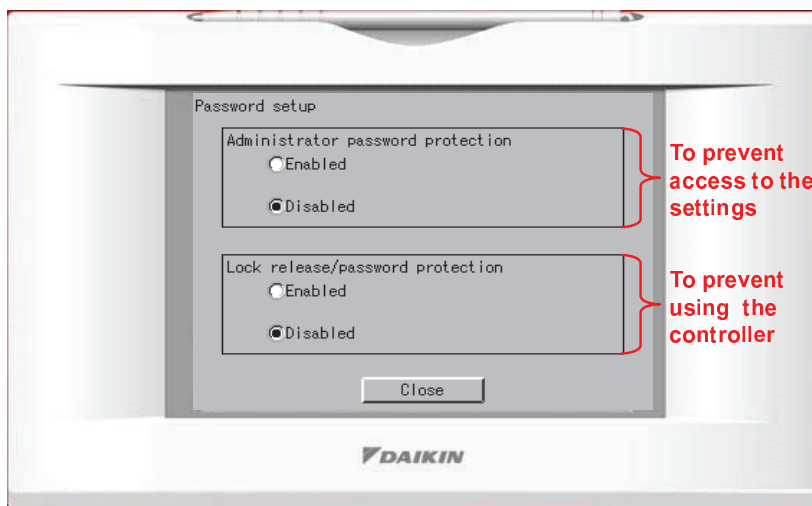



## Password Setup

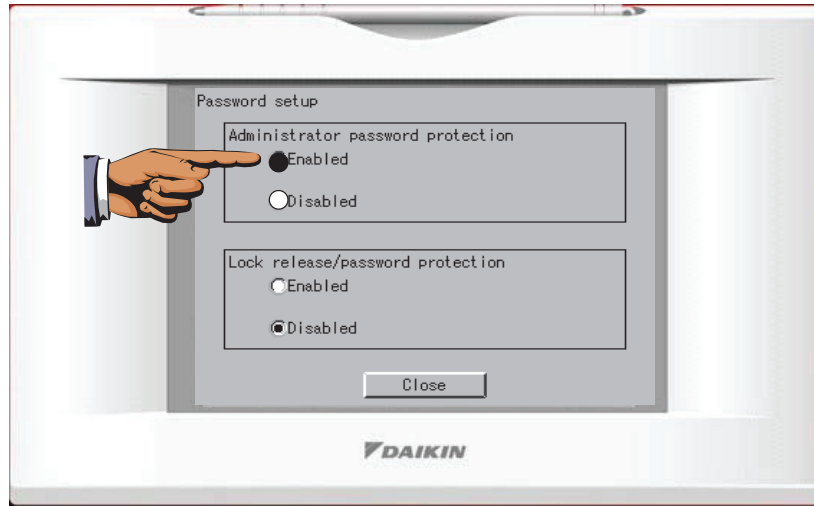

## Password Setup



## Password Setup



## Password Setup

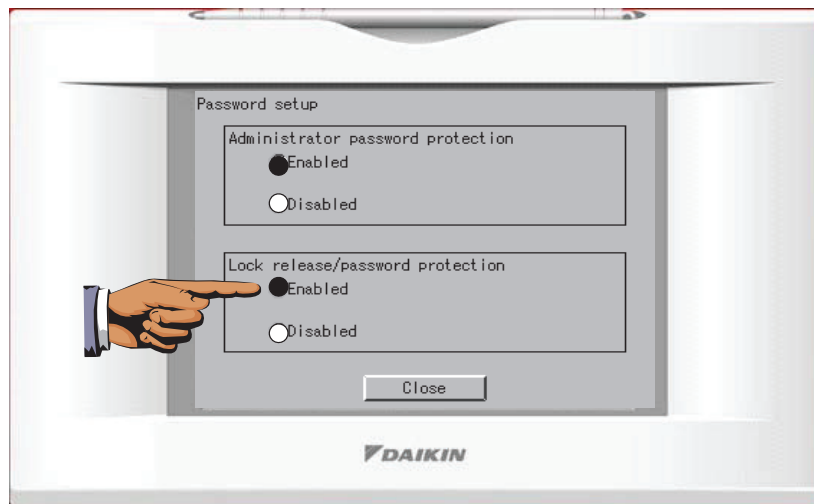

## Password Setup



## Password Setup



## Password Setup

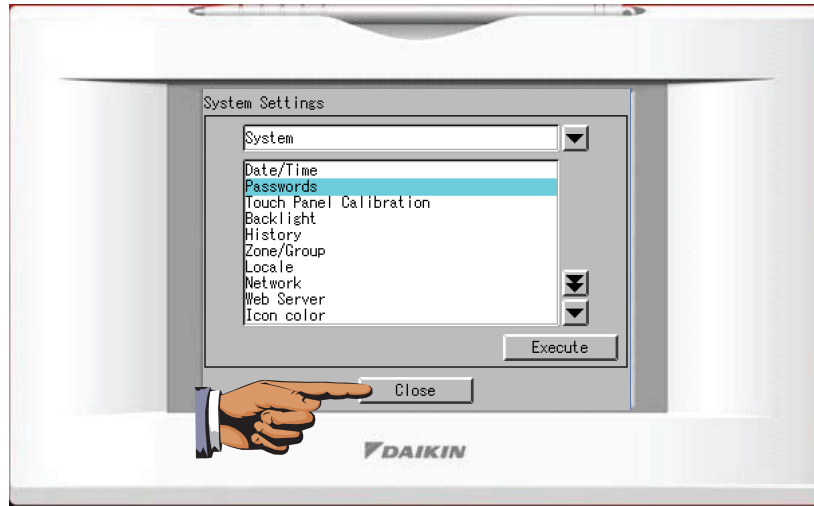

## Password Setup

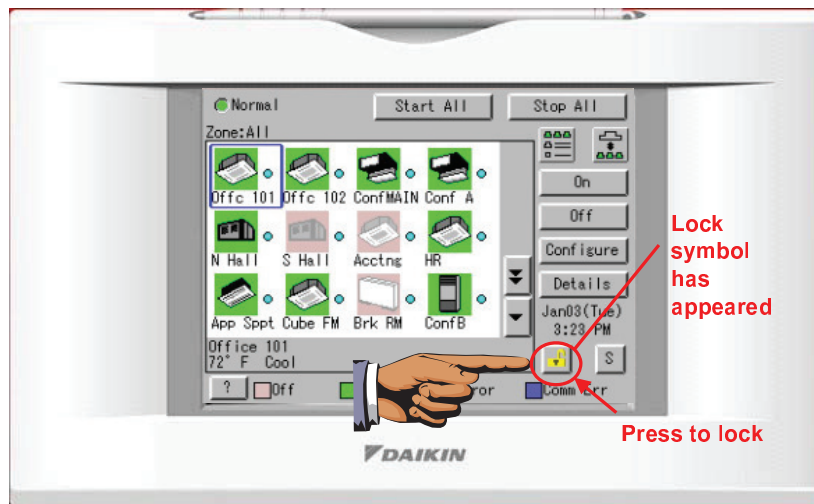

### Password Setup



### Password Setup

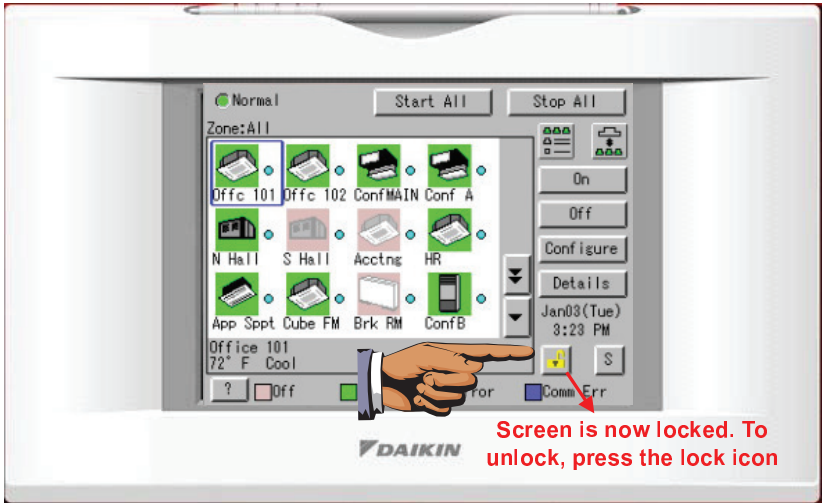

## Password Setup

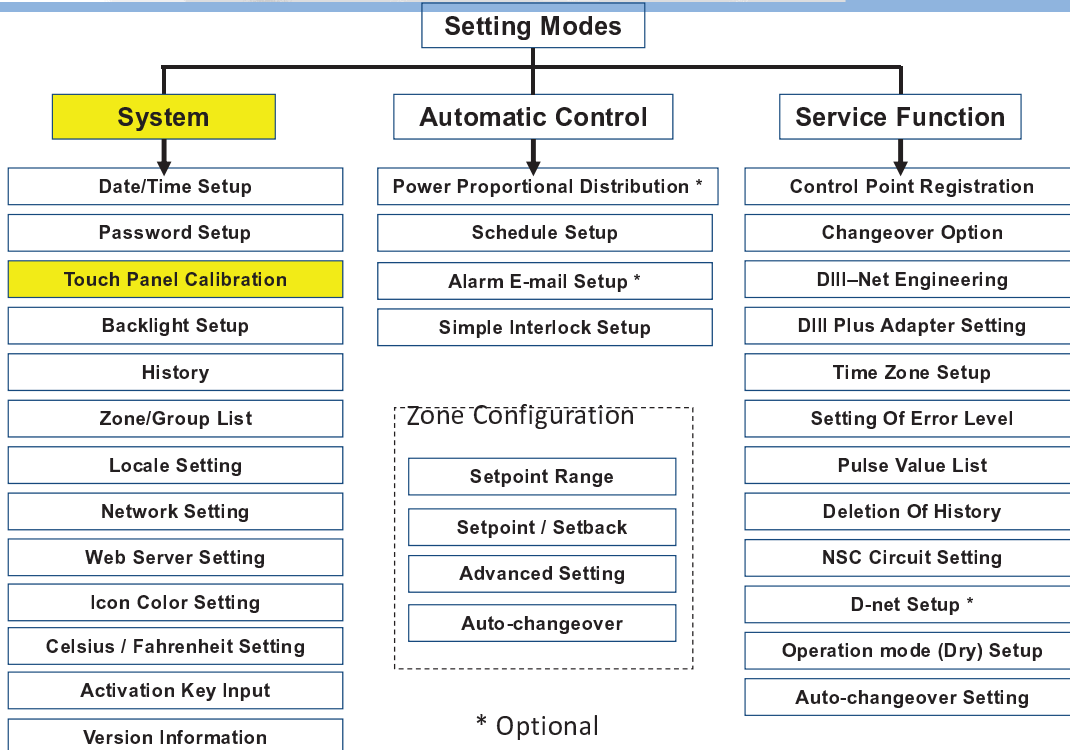

## Touch Panel Calibration

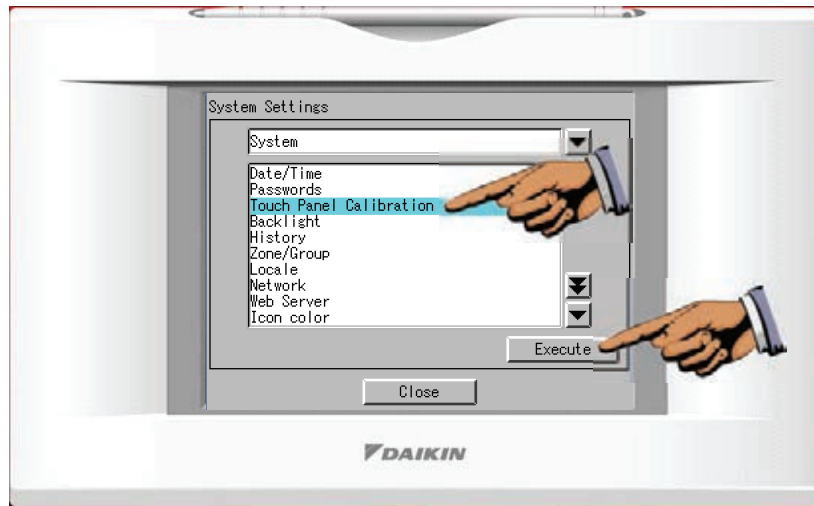

## Touch Panel Calibration

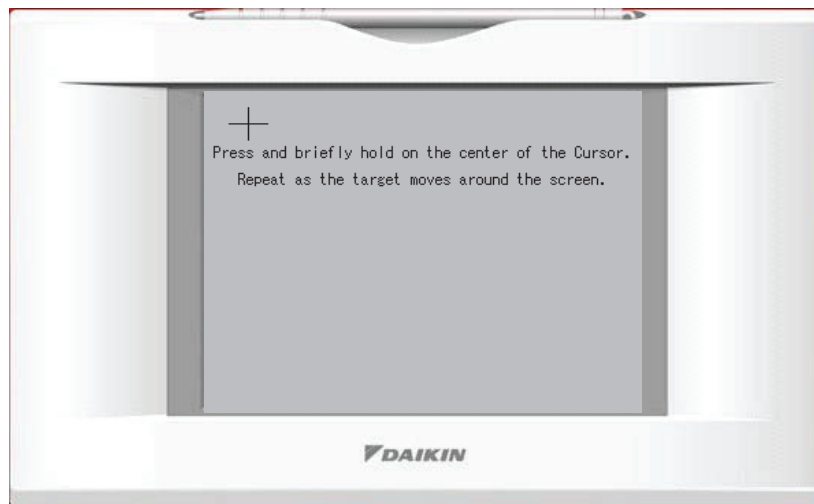

## Touch Panel Calibration

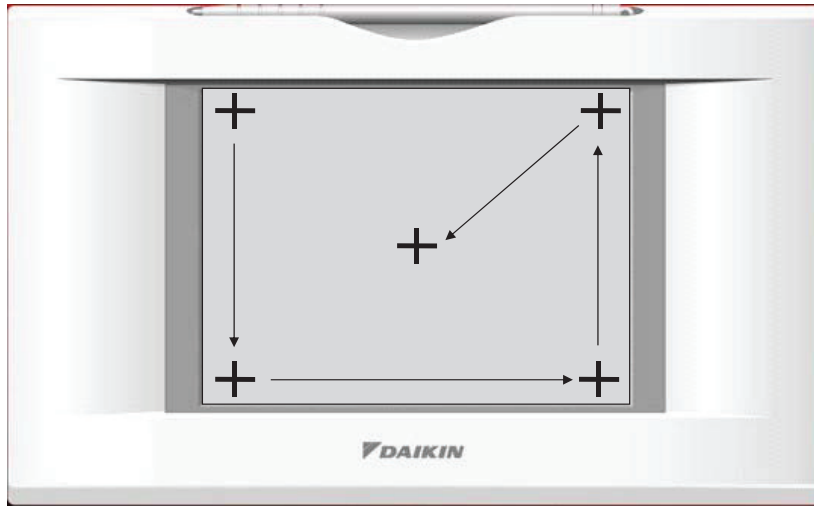

## Touch Panel Calibration

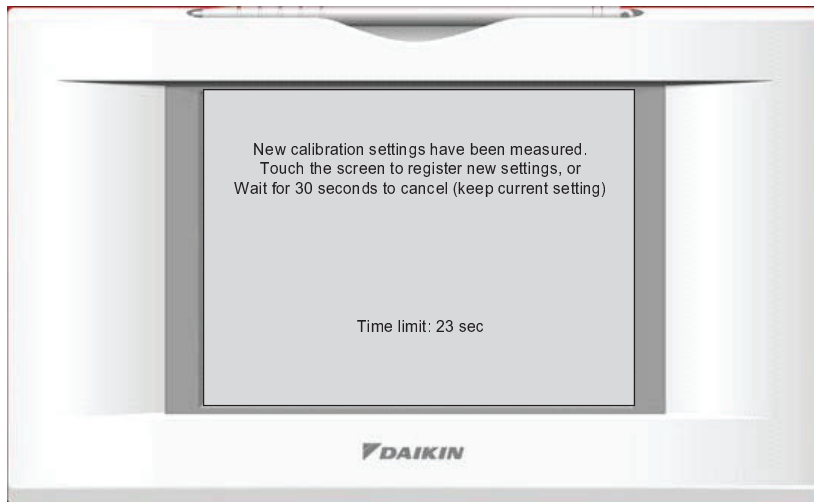



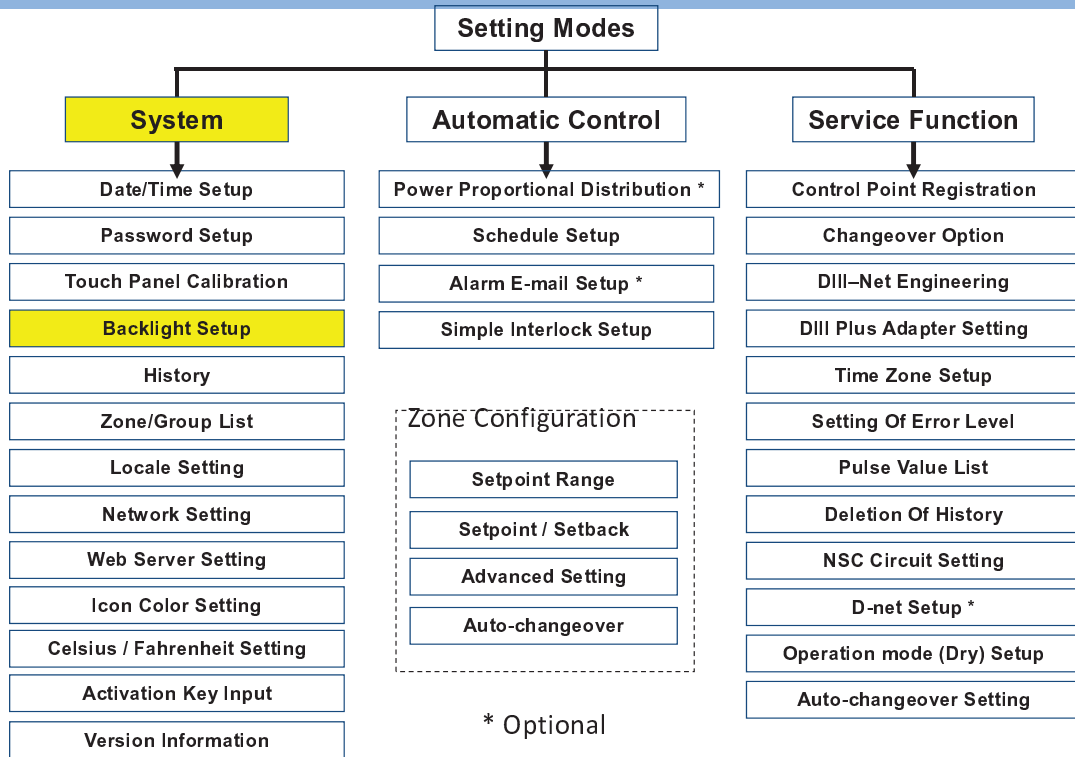

## Backlight Setup

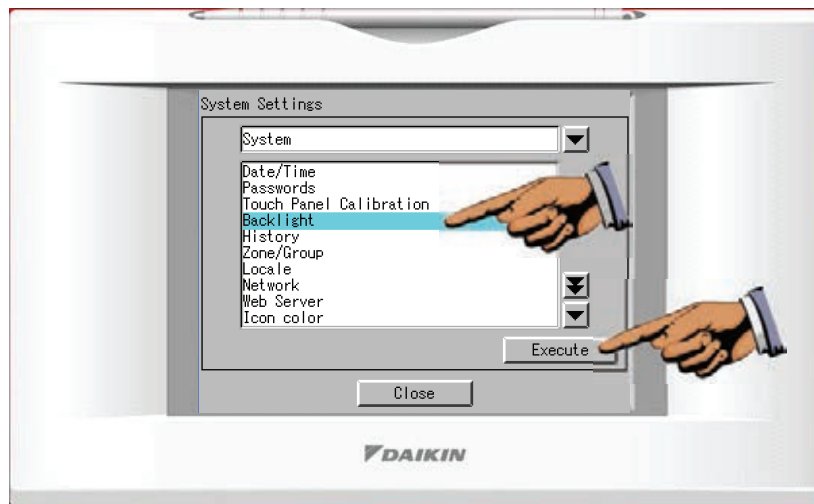

## Backlight Setup

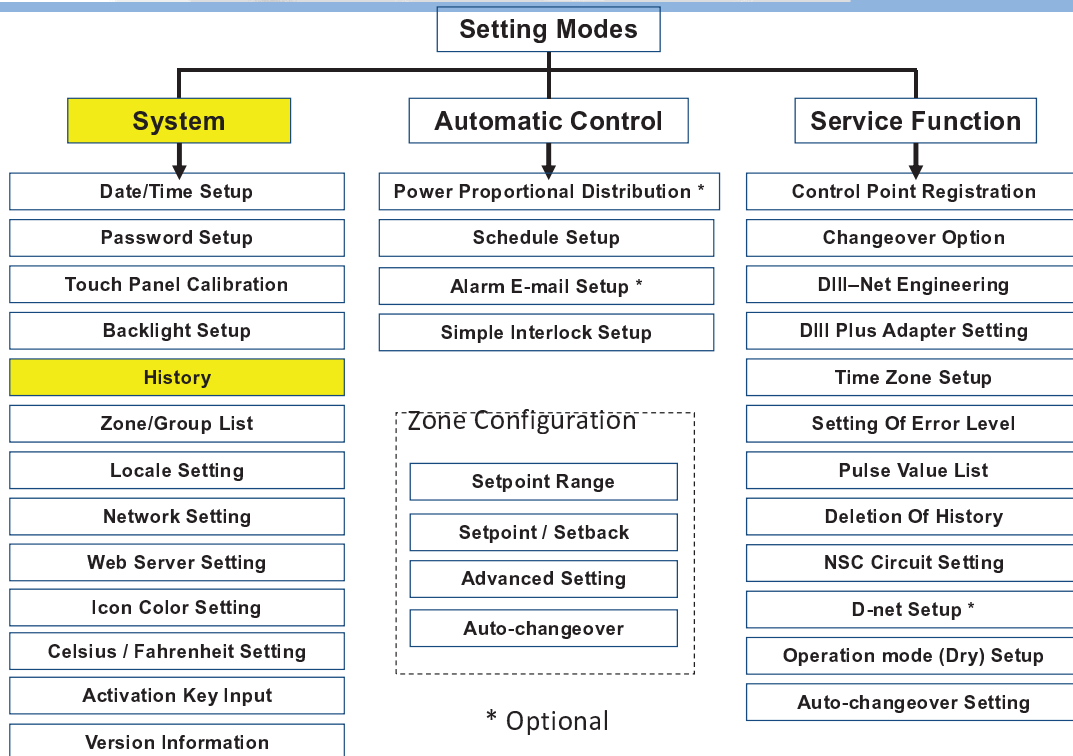
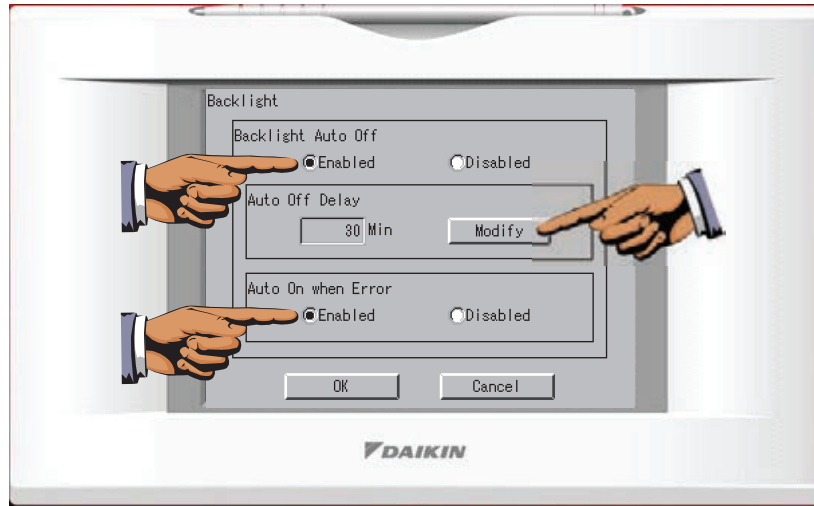

## History



## History

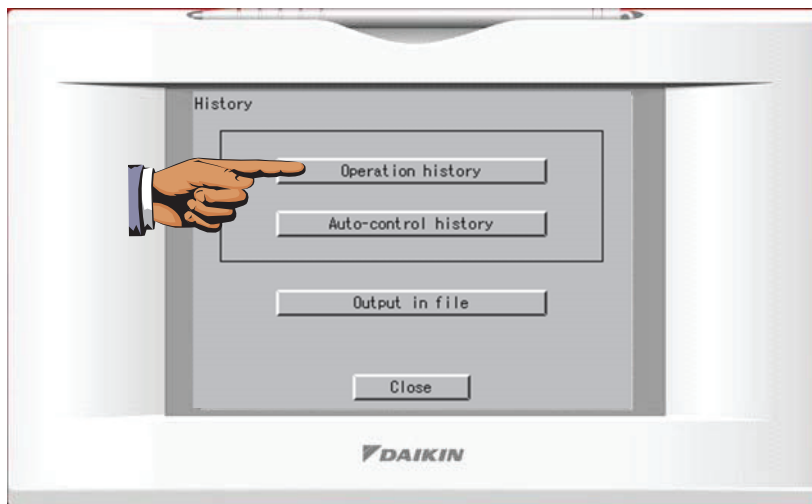

## History

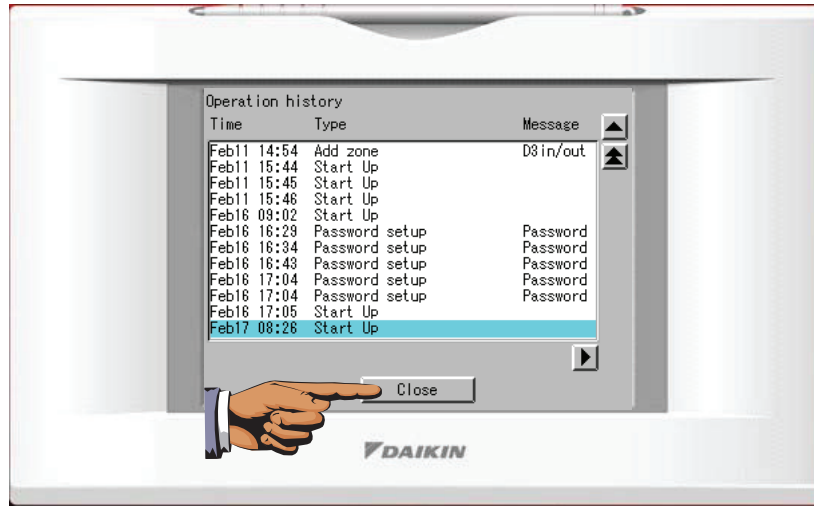

## History

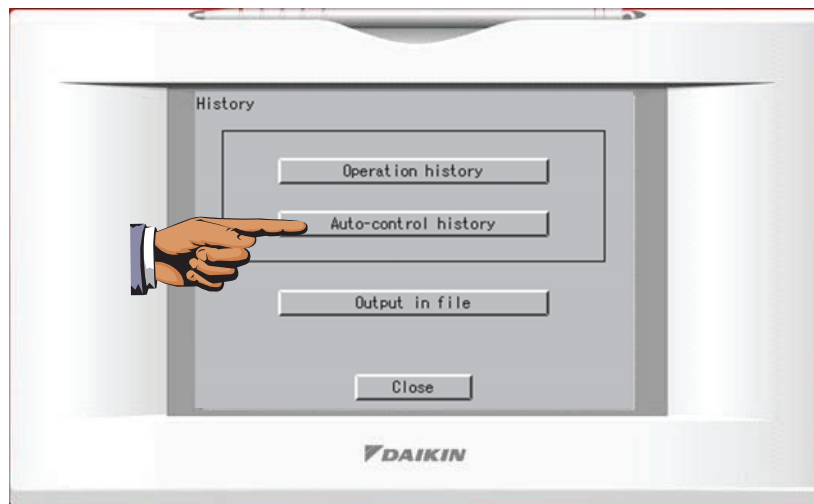

## History

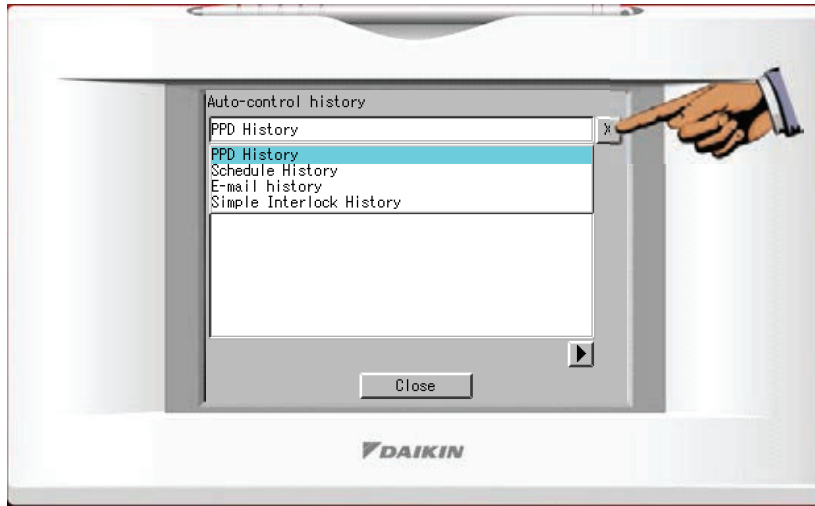

## History

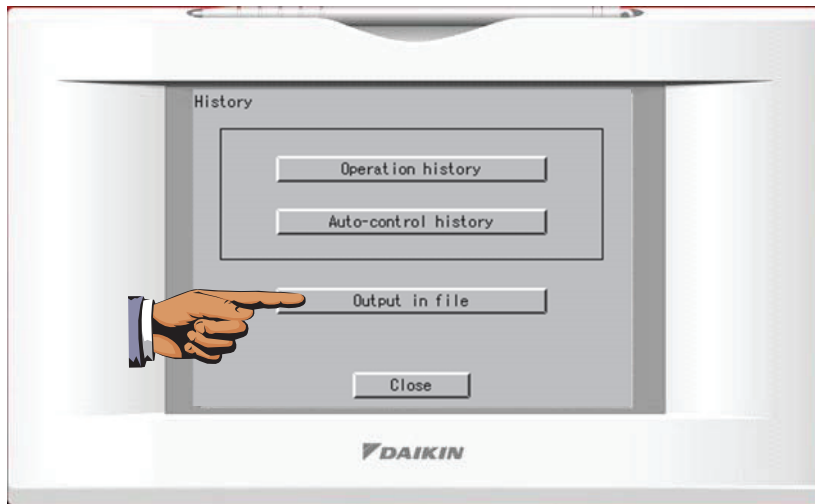

## History

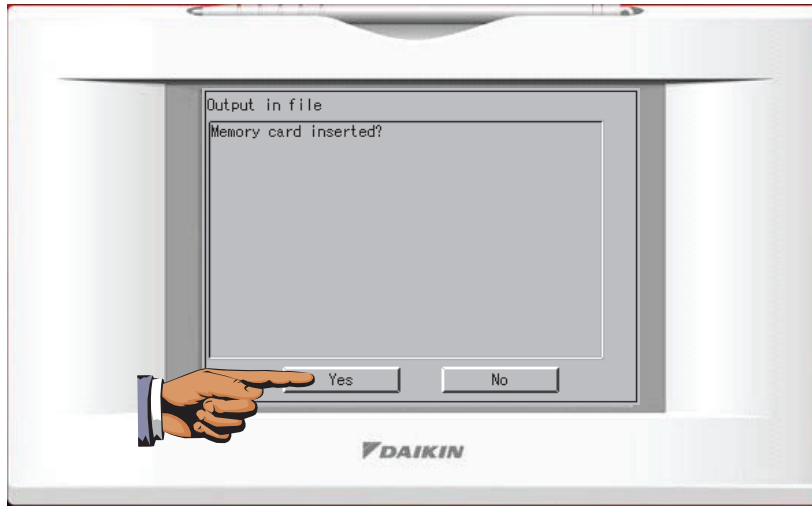

## History

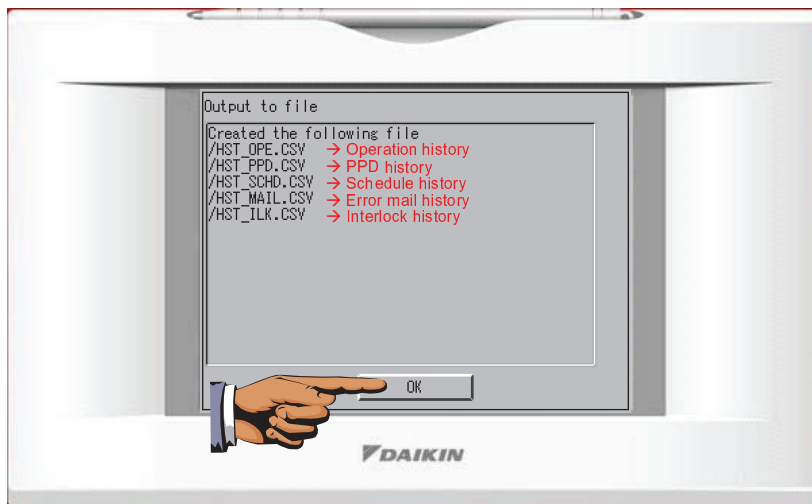

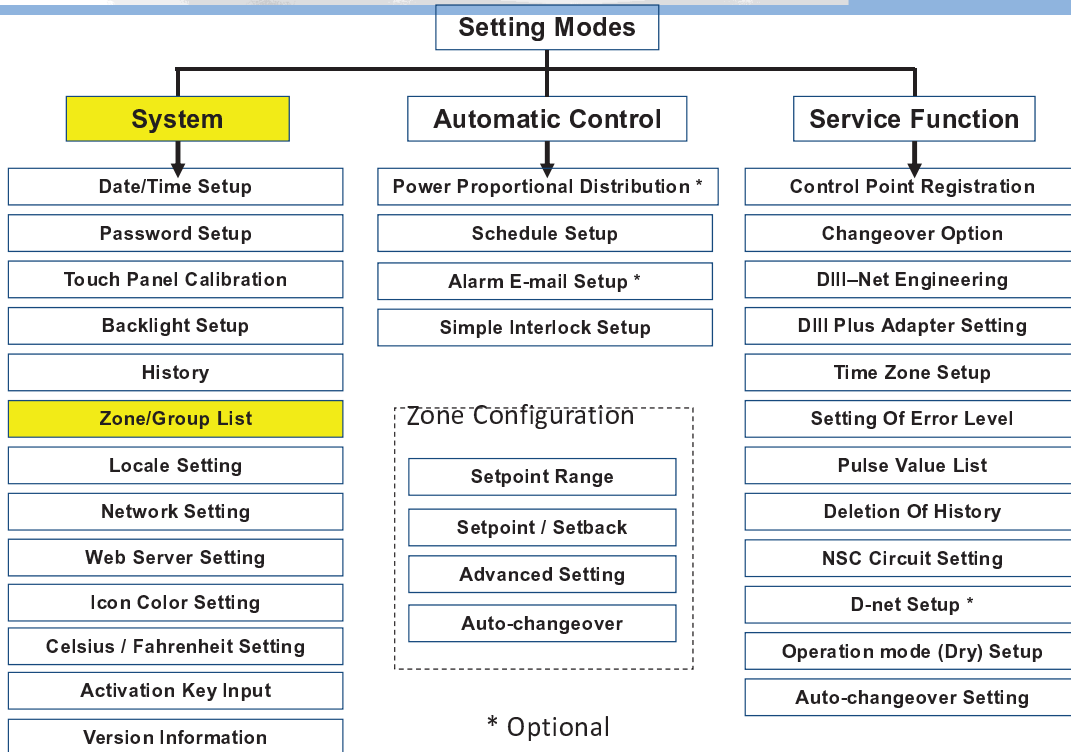

## Zone/Group List

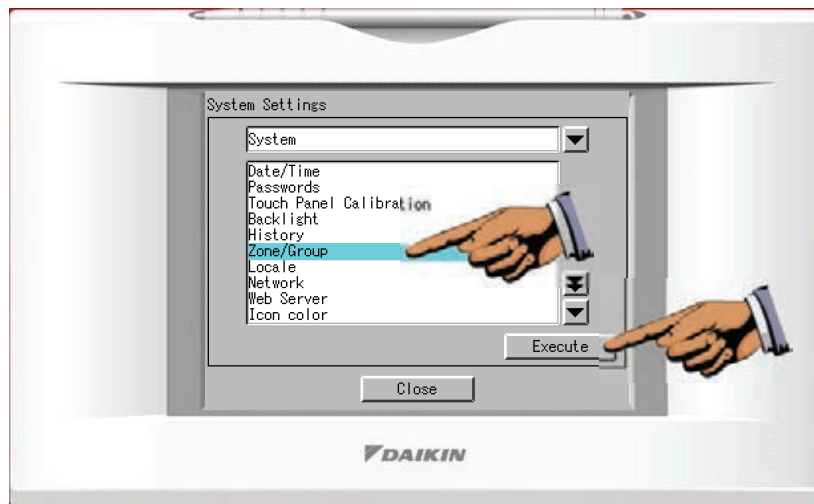

## Zone/Group List

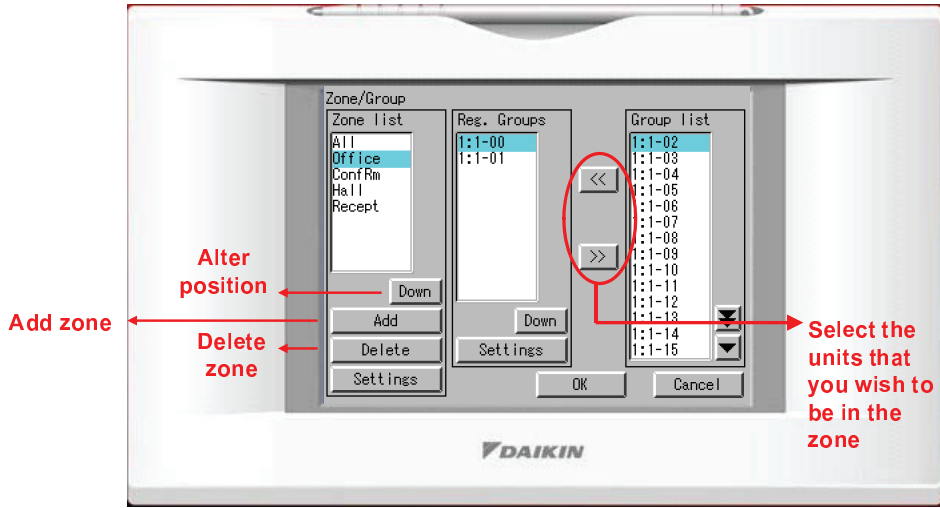

## Zone/Group List

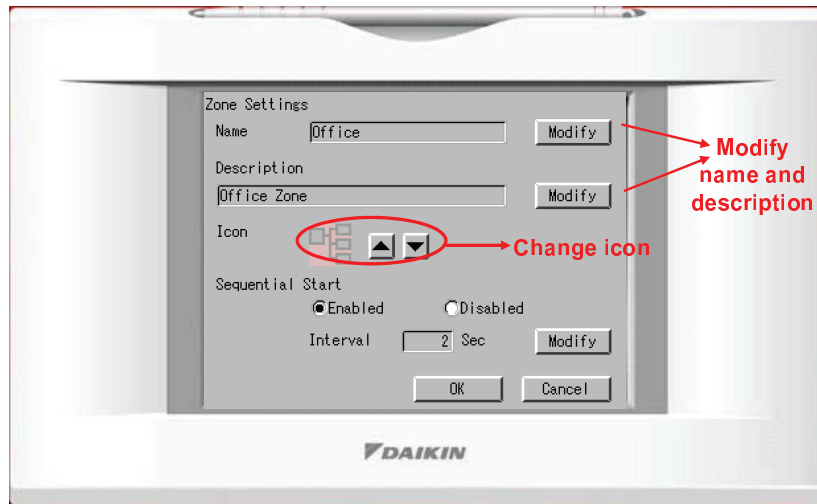



## Zone/Group List

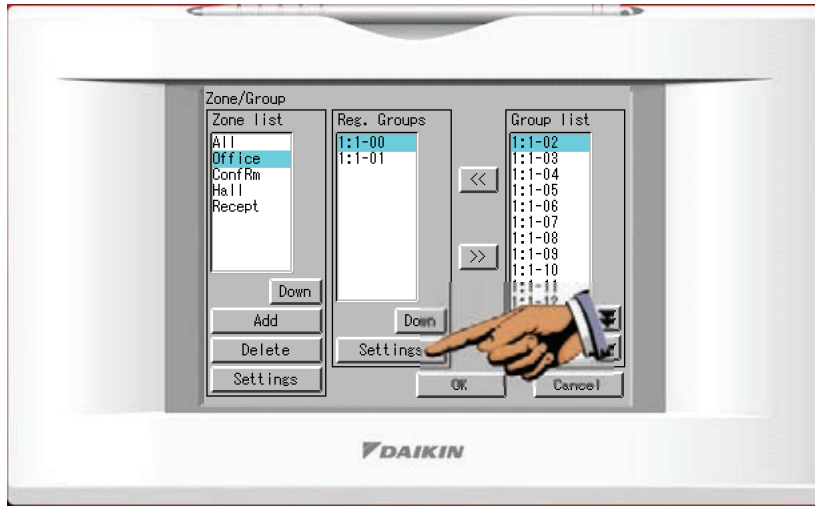

## Zone/Group List

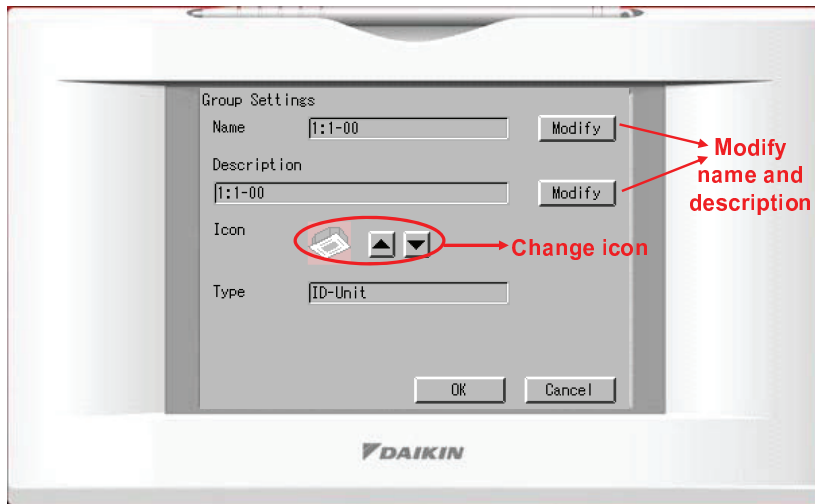

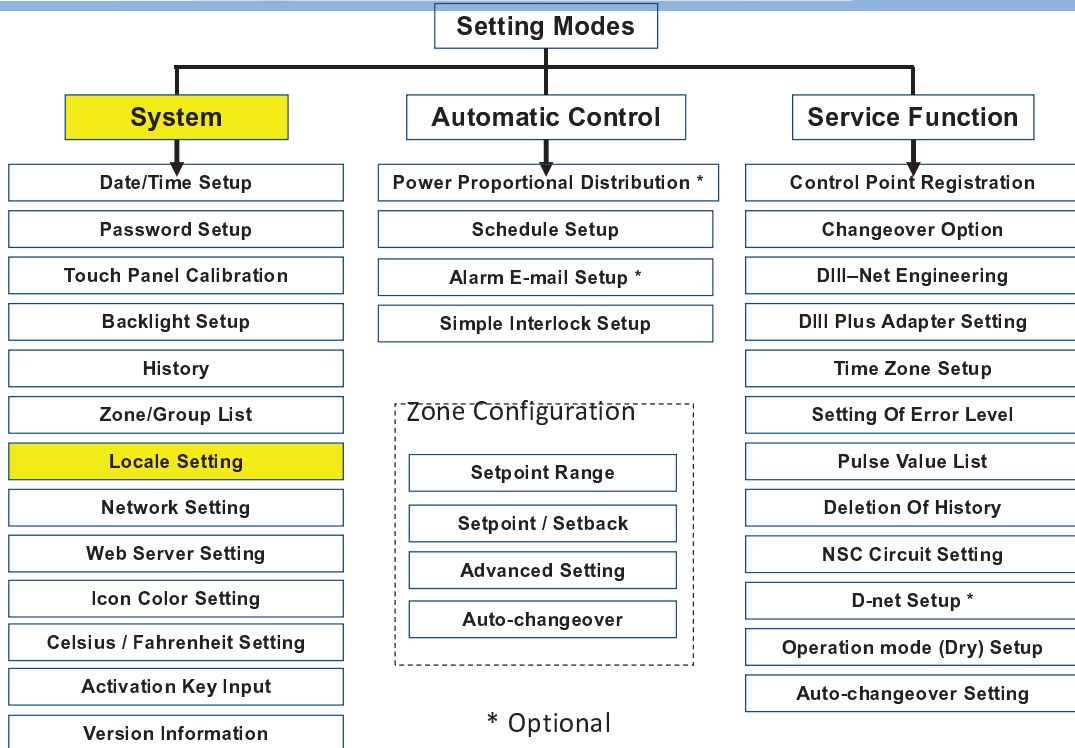

## Locale Setting

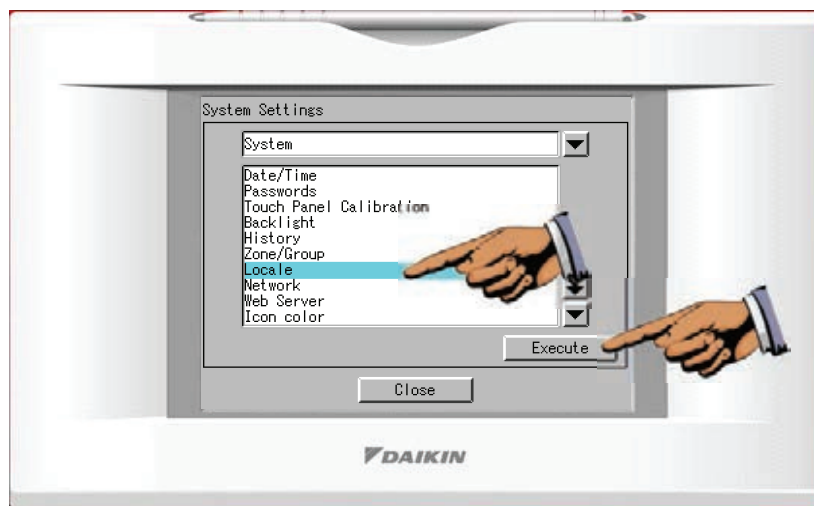

## Locale Setting

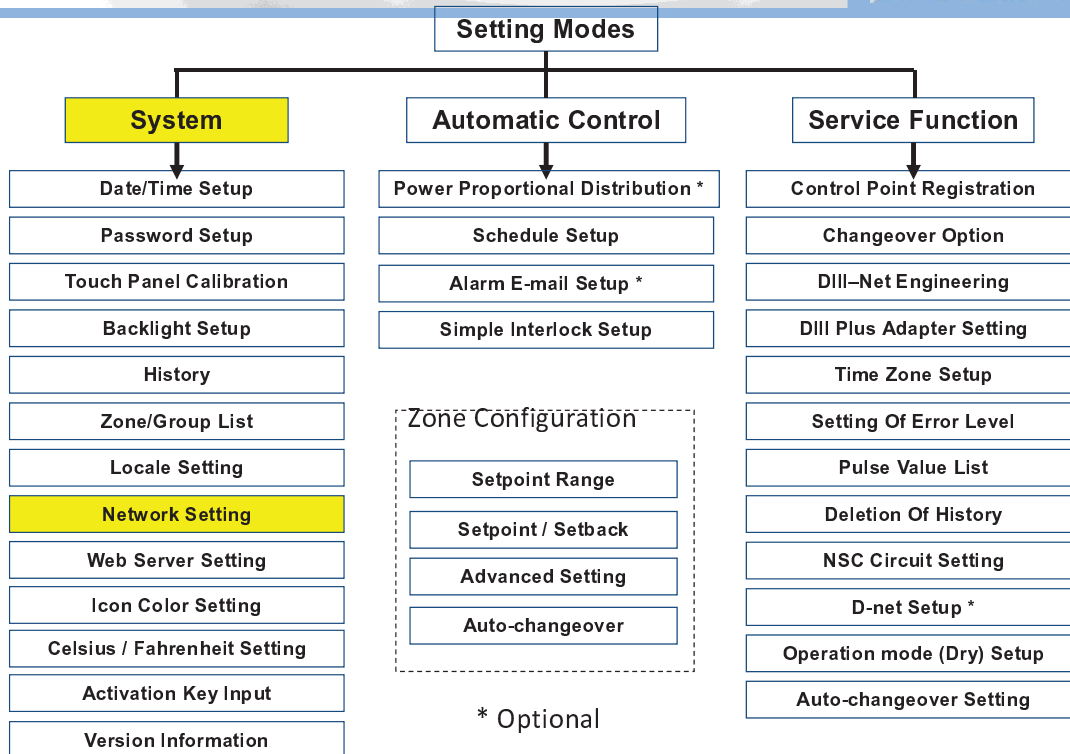

## Network Setting

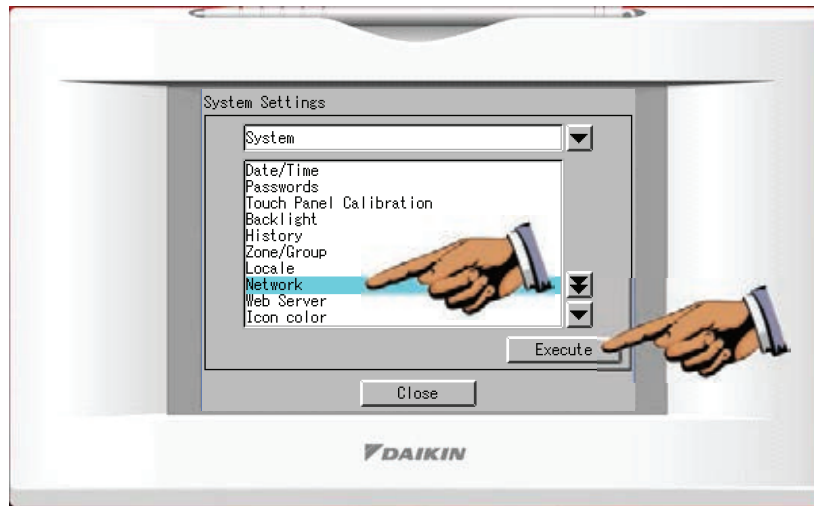

## Network Setting

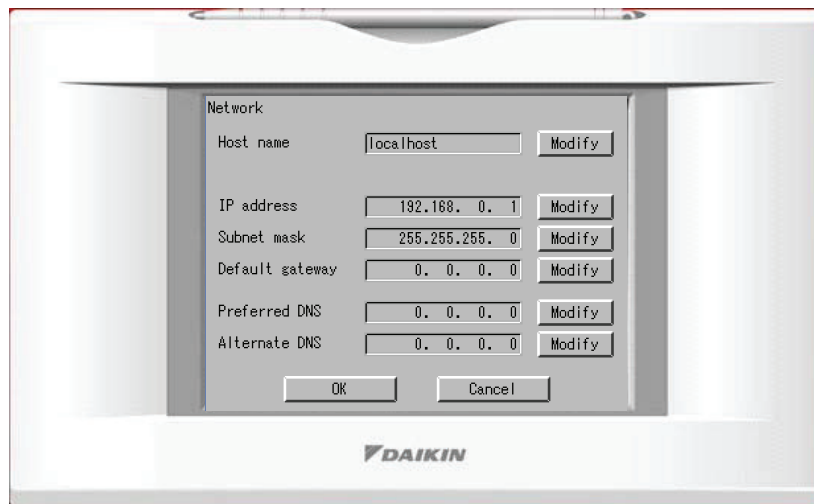

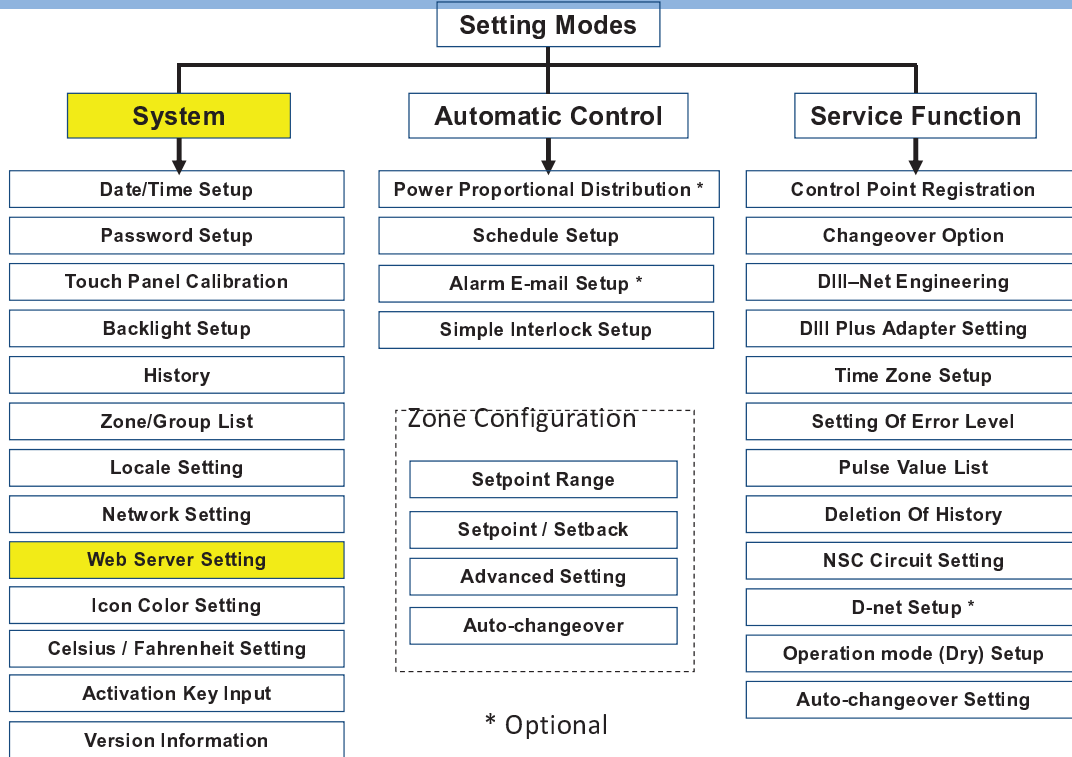

## Web Server Setting

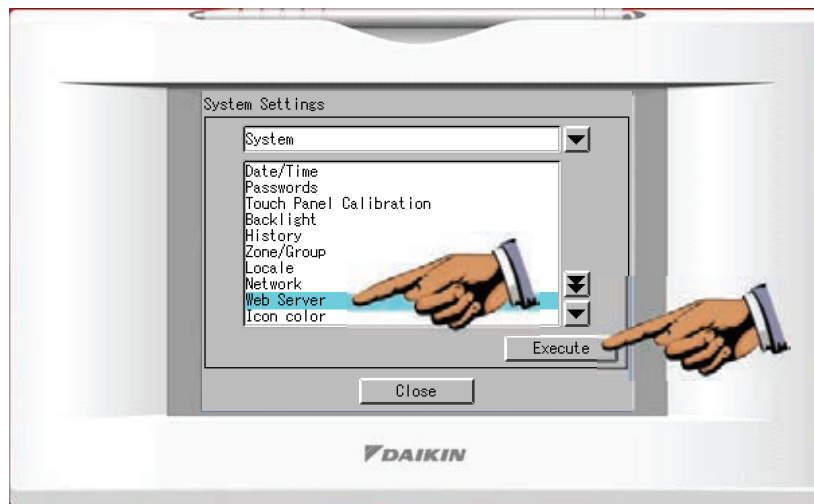

## Web Server Setting

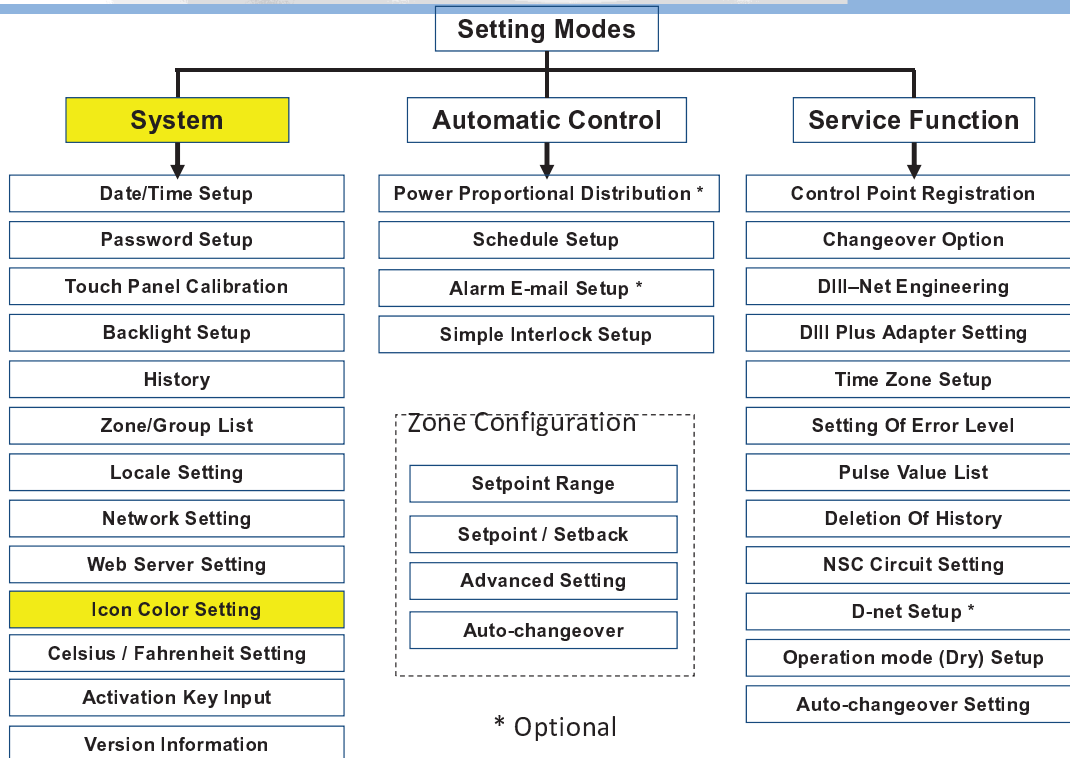
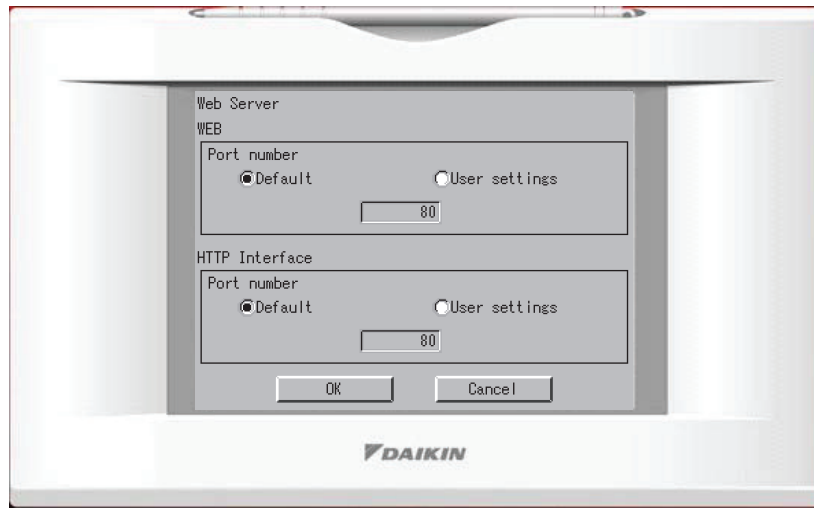

## Icon Color Setting



## Icon Color Setting

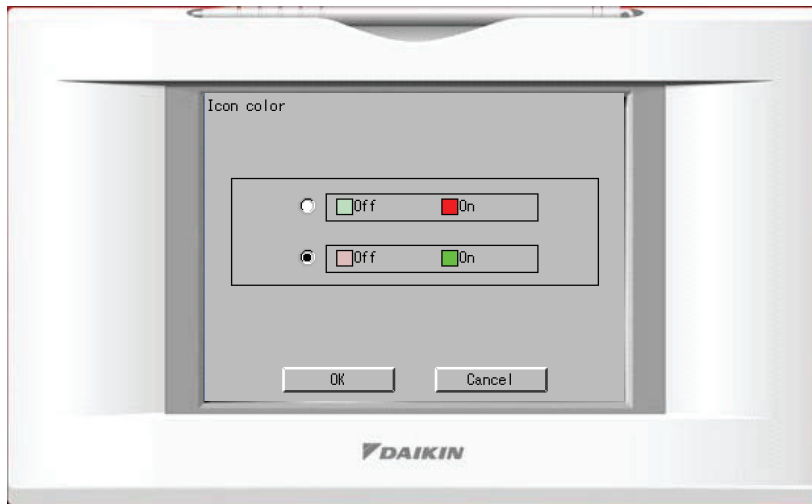

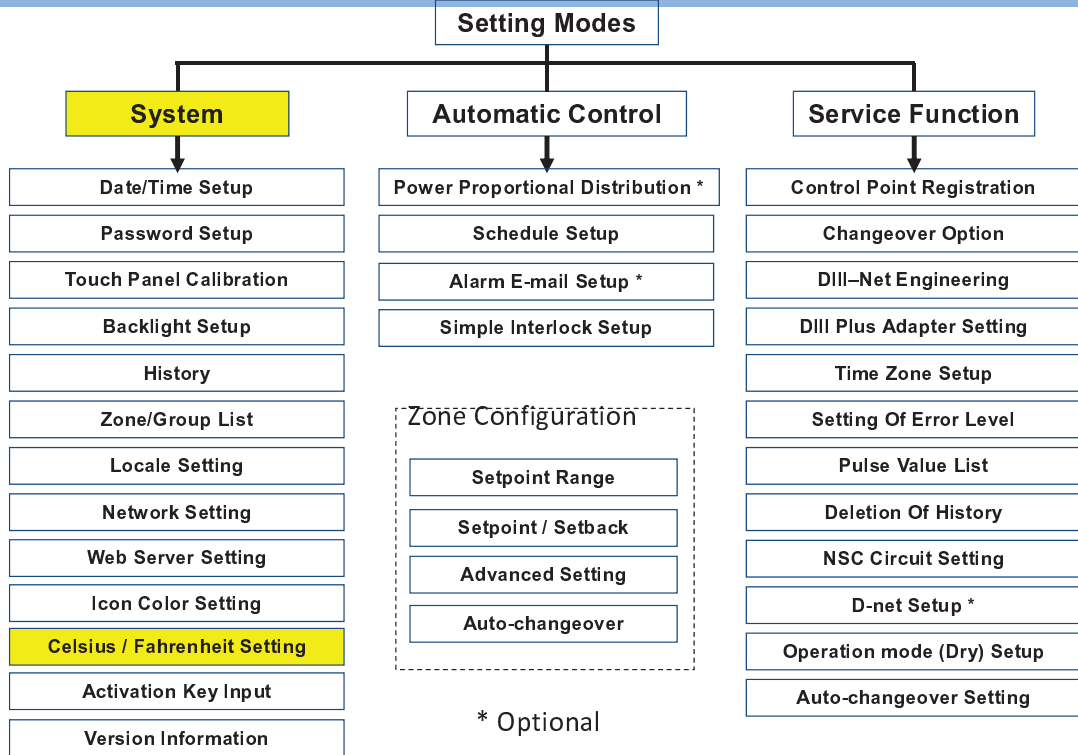

## Celsius / Fahrenheit Setting

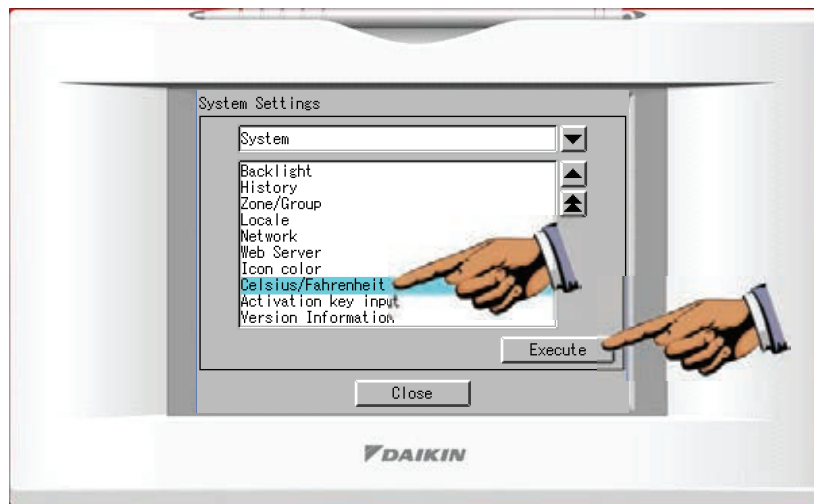



## Celsius / Fahrenheit Setting

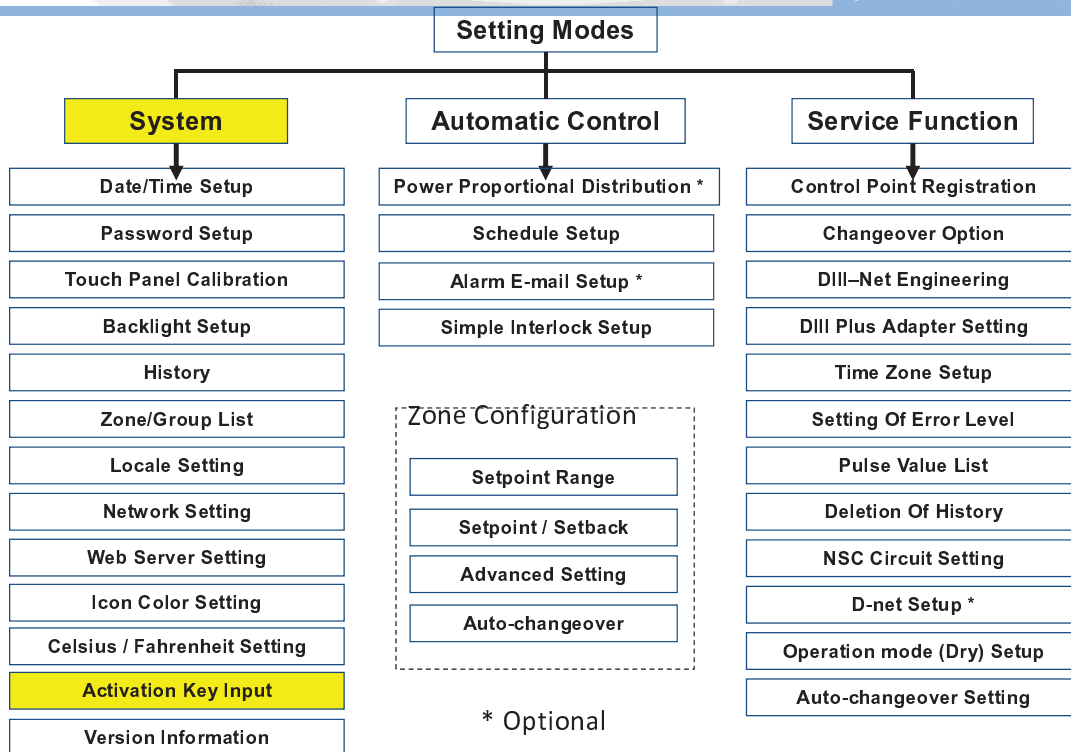
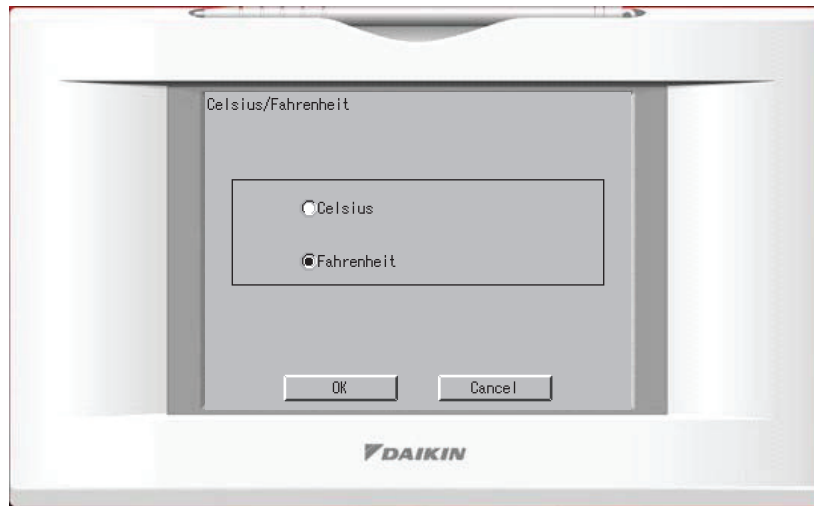

## Activation Key Input



## Activation Key Input

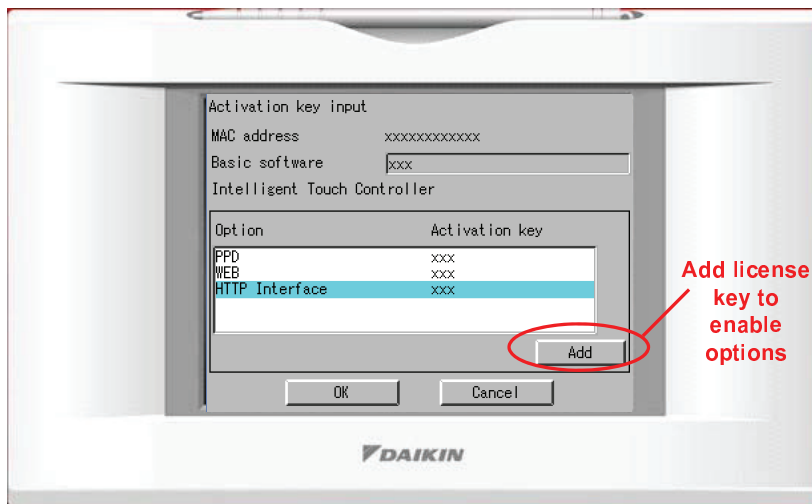

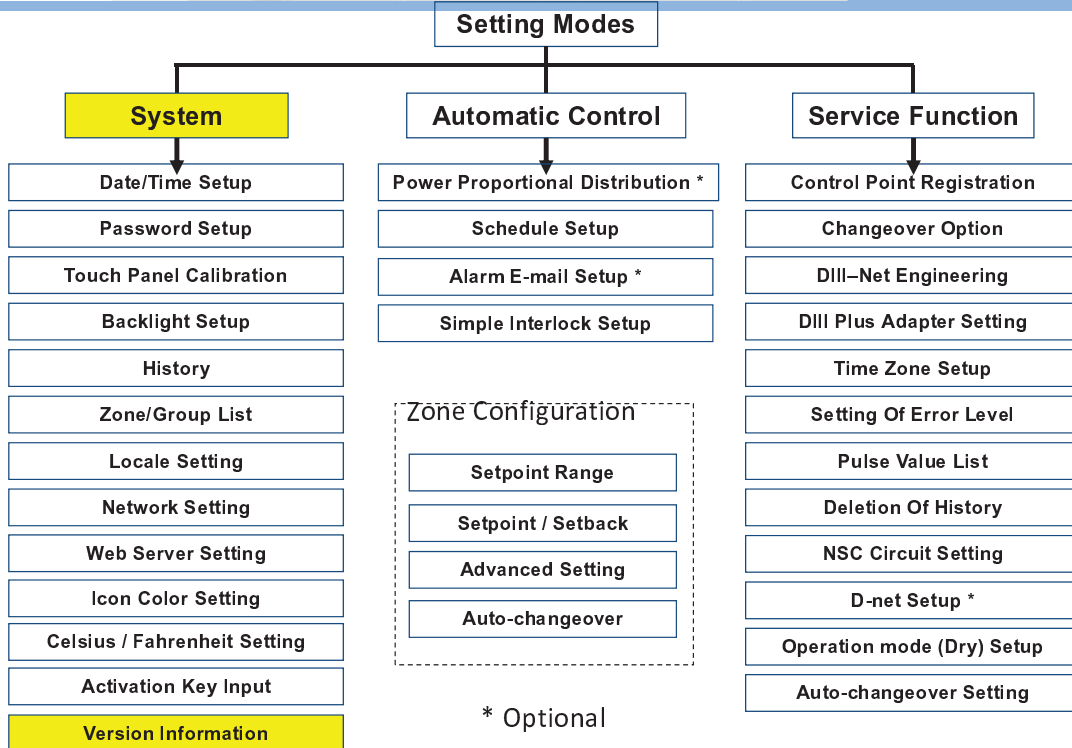

## Version Information

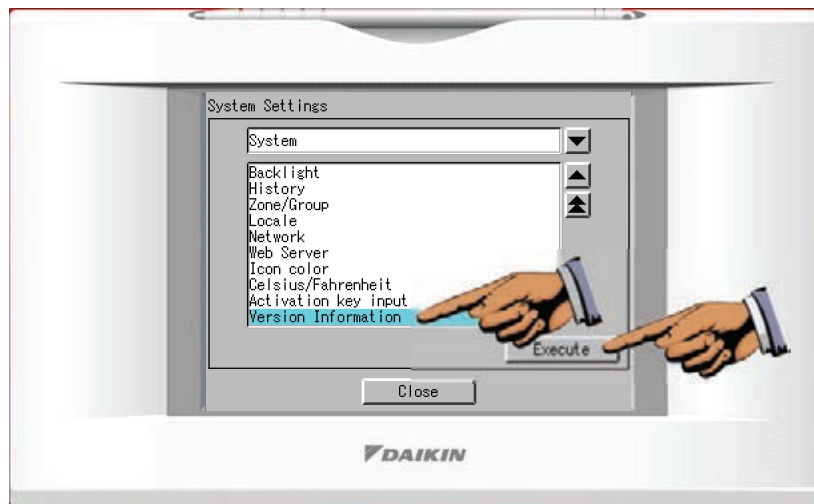

## Version Information

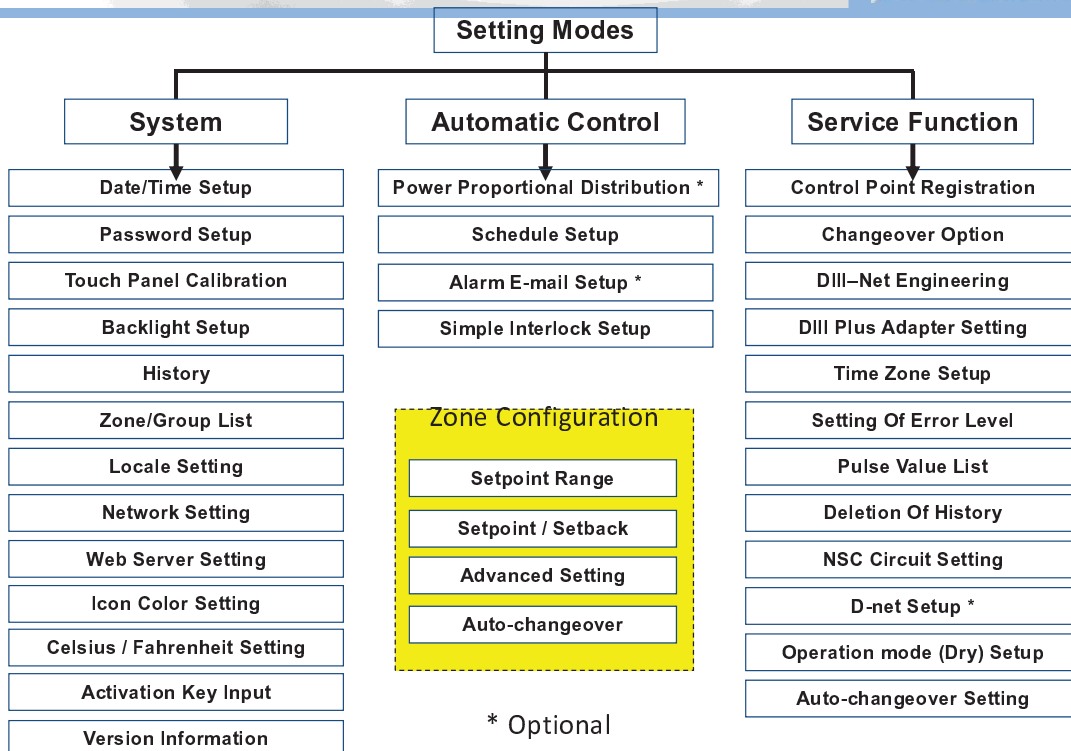

## Zone Configuration

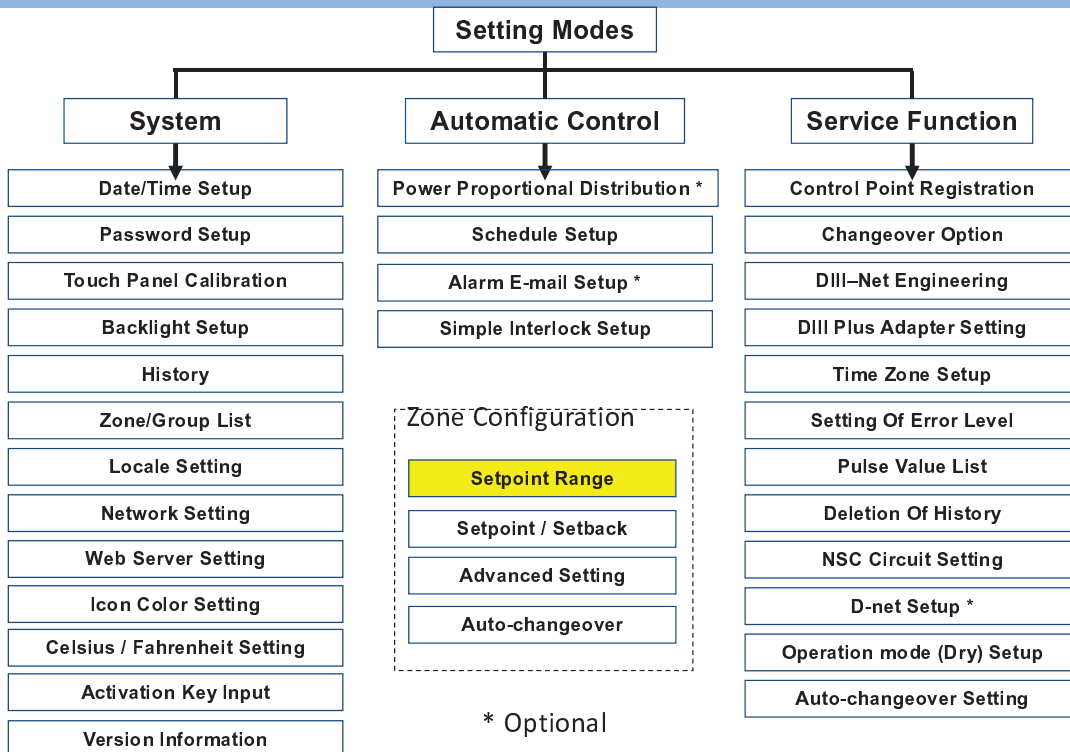
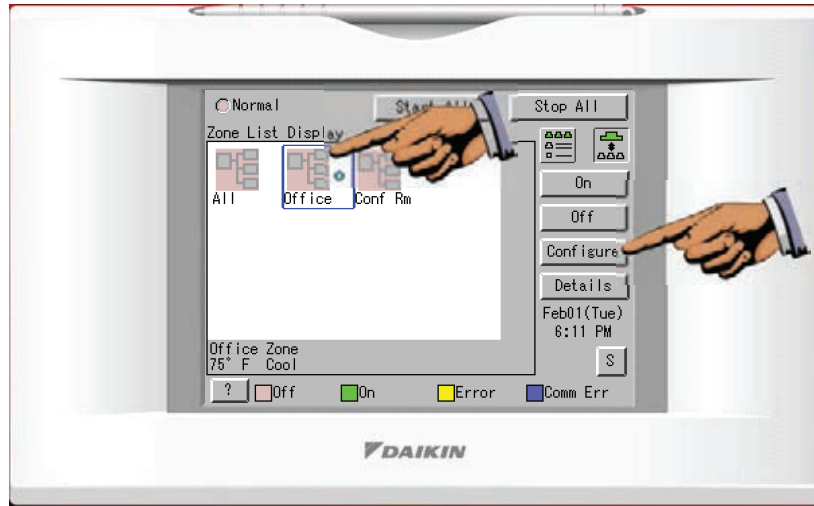

## Setpoint Range



## Setpoint Range

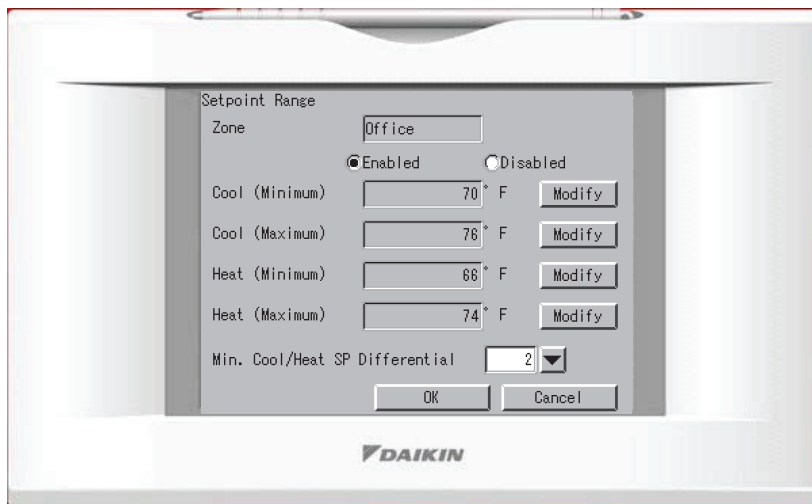

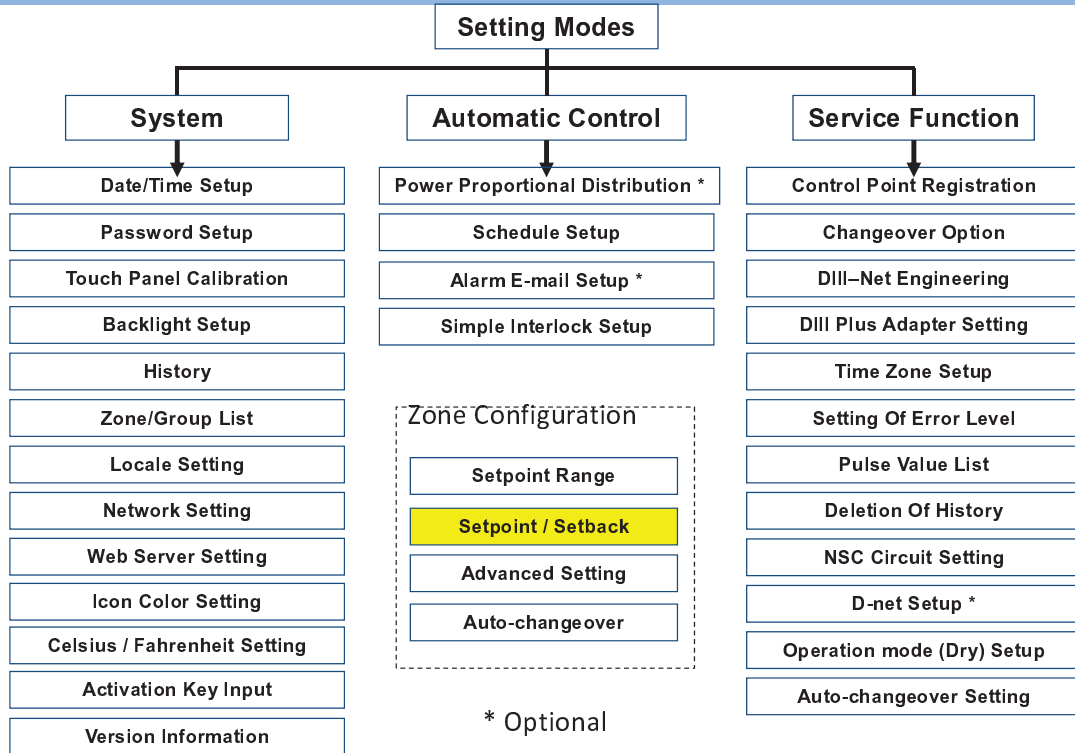

## Setpoint / Setback

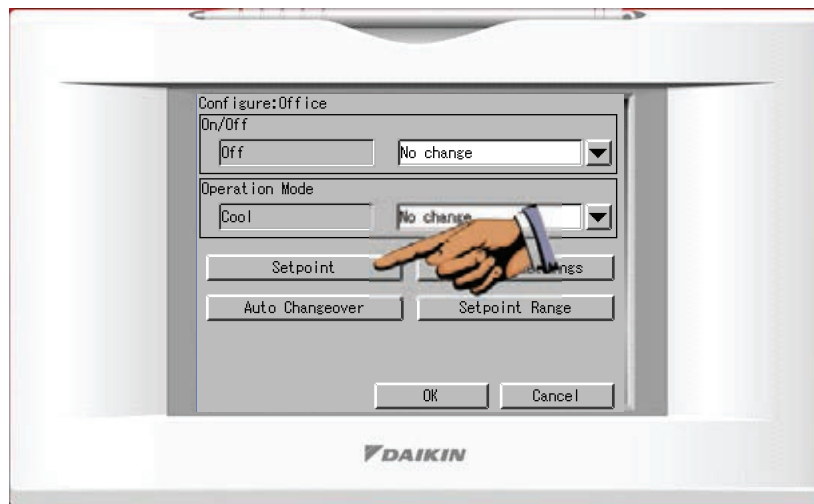

### Setpoint / Setback

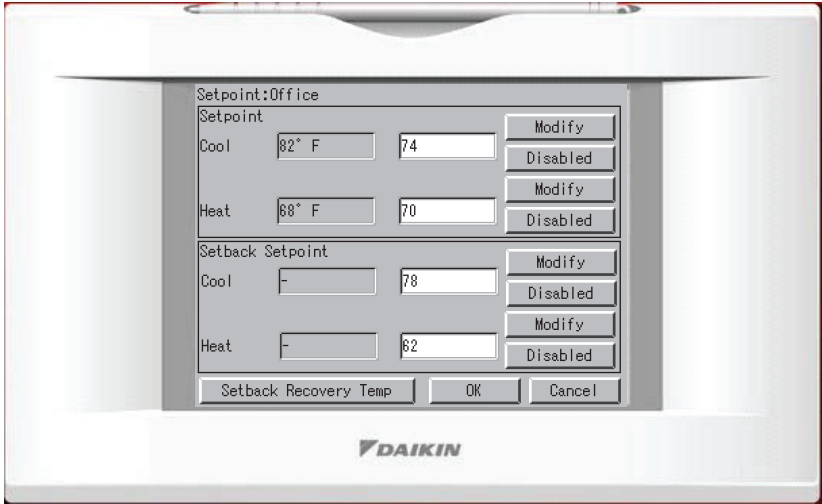

### Setpoint / Setback

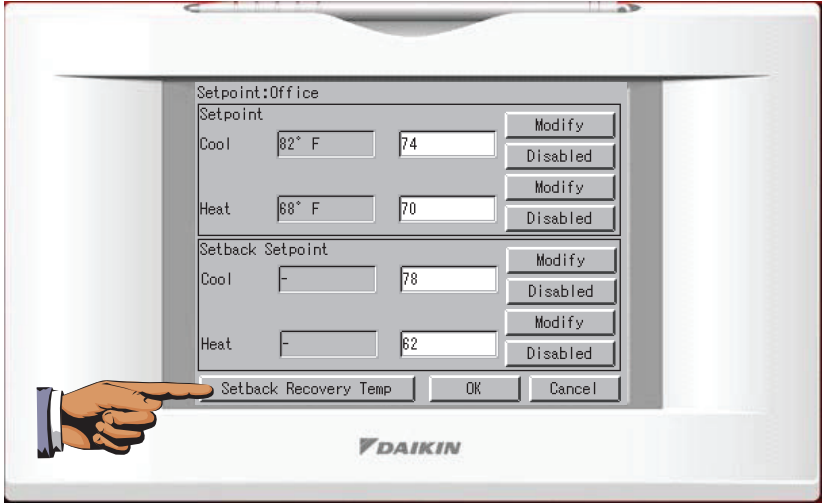



## Setpoint / Setback



## iTC V6 – Setpoint/Setback

- Independent Cooling and Heating Set-points
- Set-point Range Limit Function
- Independent Setback Set-points Outside of Occ. Set-point Range

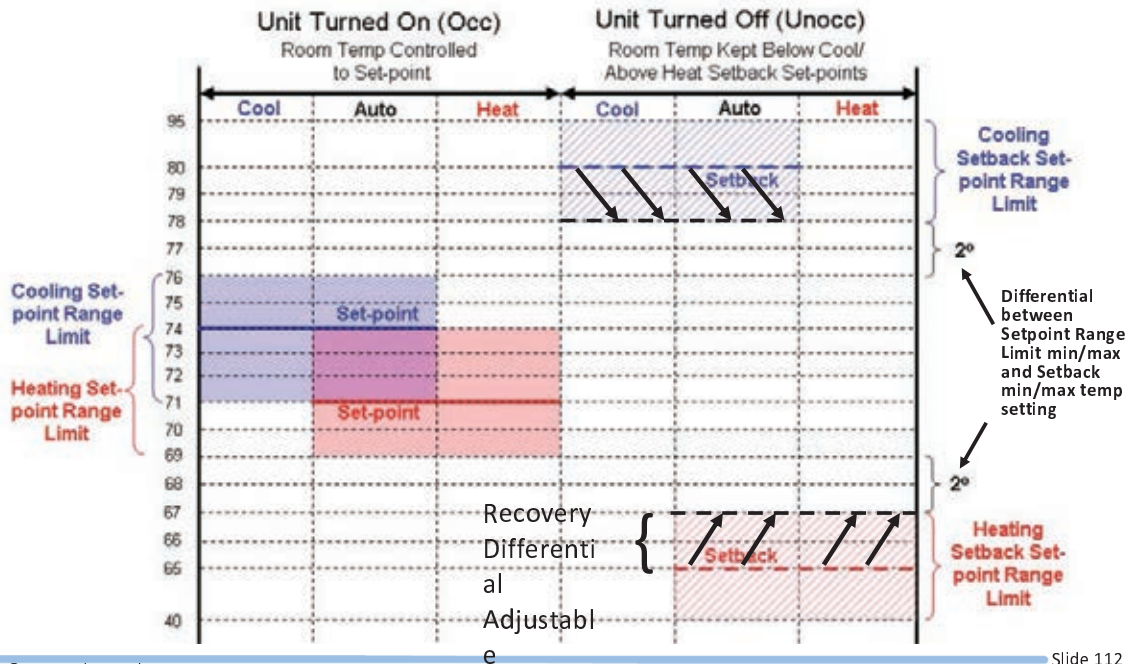

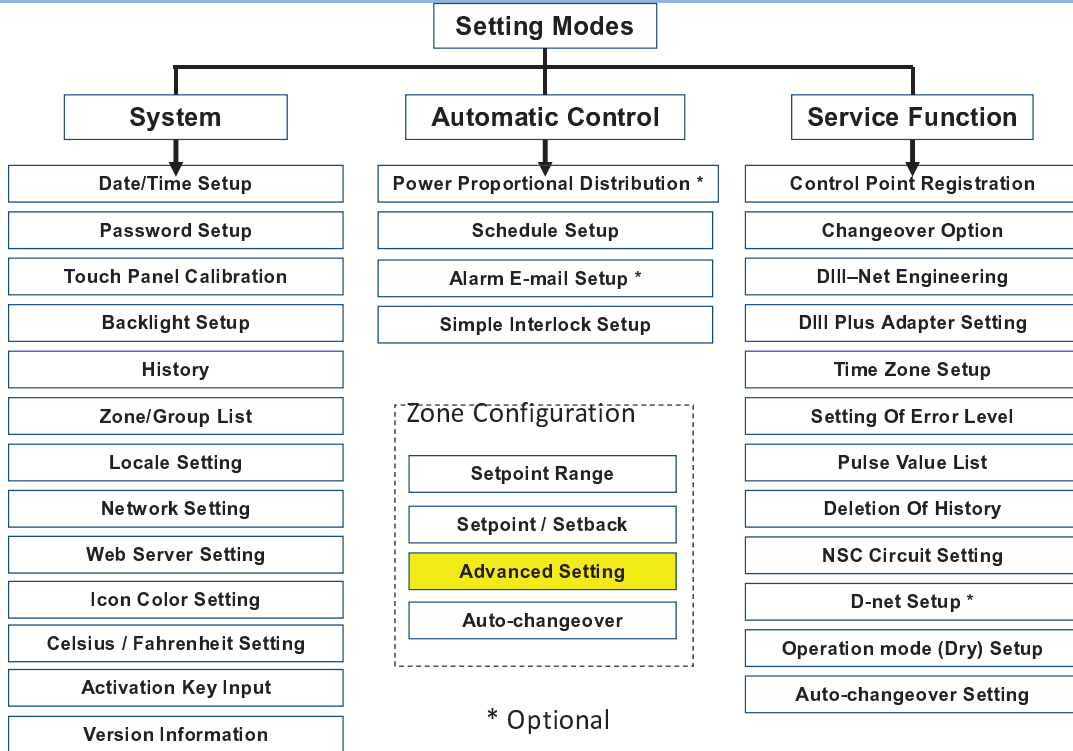

## Advanced Setting

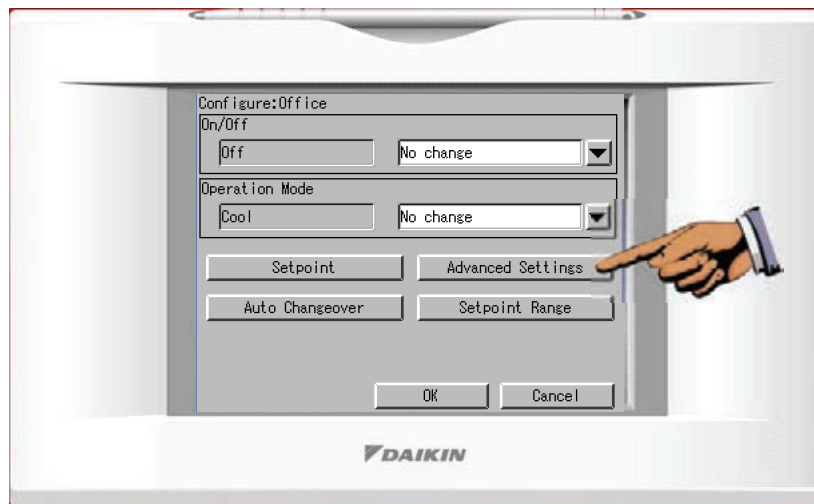

## Advanced Setting

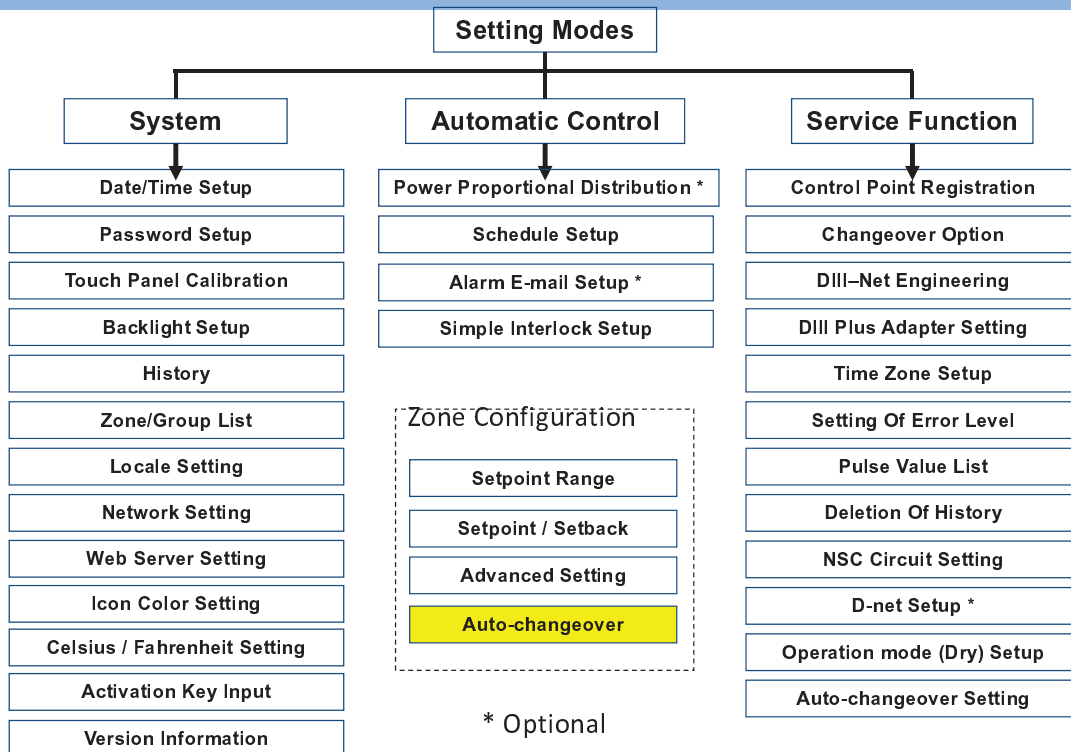

## Auto-changeover

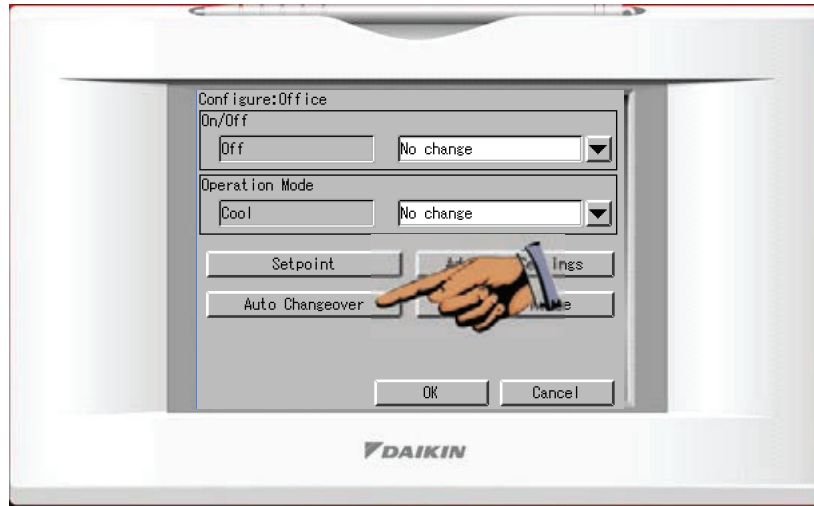

## Auto-changeover

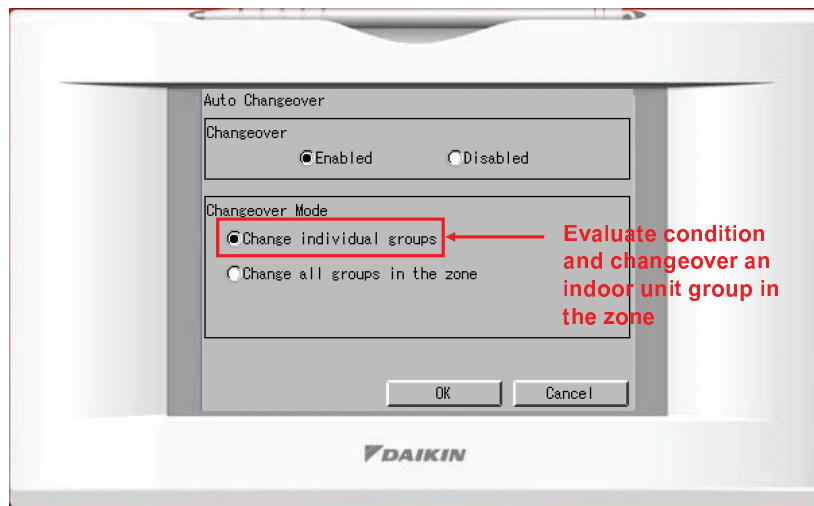

## Auto-changeover

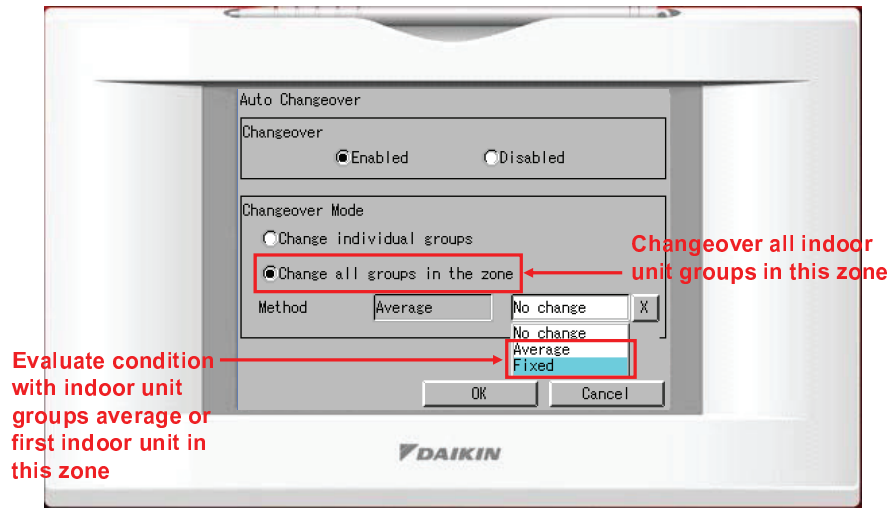

## iTC V6 – Auto-changeover

- iTC can manage Auto-changeover of indoor units in the Zone

Configuration Type	Changeover evaluated by	Changeover affects to	Good for	
			Heat Pump	Heat Recovery
<b>Individual</b>	Room temperature and setpoints of the individual indoor unit group in the Zone	Individual indoor unit group in the zone		✓
<b>Fixed</b>	Room temperature and setpoints of the representative unit (first registered unit) in the Zone	All indoor unit groups in the zone	✓	✓
<b>Averaging</b>	Room temperature and setpoints of the average of all indoor unit groups in the Zone		✓	✓

# iTC V6 – Auto-changeover



## Auto-changeover and Setpoint Differentials

- Changeover point  
To Cool:  
(RT >= CSP) &  
(RT >= Ave. of CSP & HSP + 2.7F)
- To Heat:  
(RT <= HSP) &  
(RT <= Ave. of CSP & HSP - 2.7F)

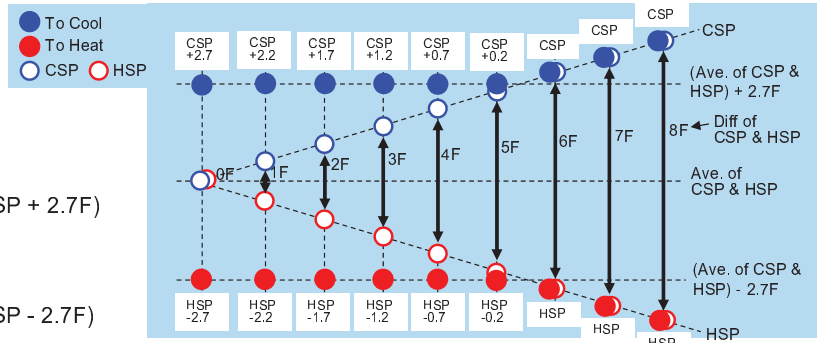

- 1 Hour Guard timer
  - Upon changeover, guard timer will prevent another changeover during this period.
  - Guard timer is ignored by a change of setpoint manually (from either iTC or Remote Controller) or by schedule.
  - 60 min as default, configurable to 15, 30 or 90 min (Service Settings Menu)

# Auto-changeover



## Example 1

### CASE 1)

When the difference between Cooling Setpoint (C\_SP) and Heating Setpoint (H\_SP) is less than 5.4° F (3.0° C).

- ① Change to Cool mode: Main room temp  $\geq$  Average of C\_SP & H\_SP + 2.7° F (1.5° C)
- ② Change to Heat mode: Main room temp  $\leq$  Average of C\_SP & H\_SP - 2.7° F (1.5° C)

**Example:** In case of C\_SP = 74° F and H\_SP = 70° F,

- ① Change to Cool mode at Main room temp  $\geq$  74.7° F  $\leftarrow (74 + 70) / 2 + 2.7$
- ② Change to Heat mode at Main room temp  $\leq$  69.3° F  $\leftarrow (74 + 70) / 2 - 2.7$

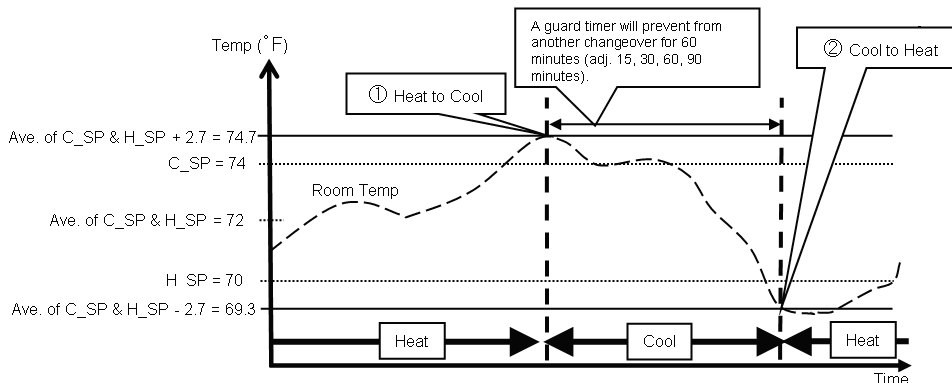

# Auto-changeover



## Example 2

### CASE 2)

When the difference between Cooling Setpoint (C\_SP) and Heating Setpoint (H\_SP) is equal to or greater than 5.4° F (3.0° C).

- ① Change to Cool mode: Main room temp  $\geq$  C\_SP
- ② Change to Heat mode: Main room temp  $\leq$  H\_SP

**Example:** In case of C\_SP = 76° F and H\_SP = 70° F,

- ① Change to Cool mode at Main room temp  $\geq$  76° F
- ② Change to Heat mode at Main room temp  $\leq$  70° F

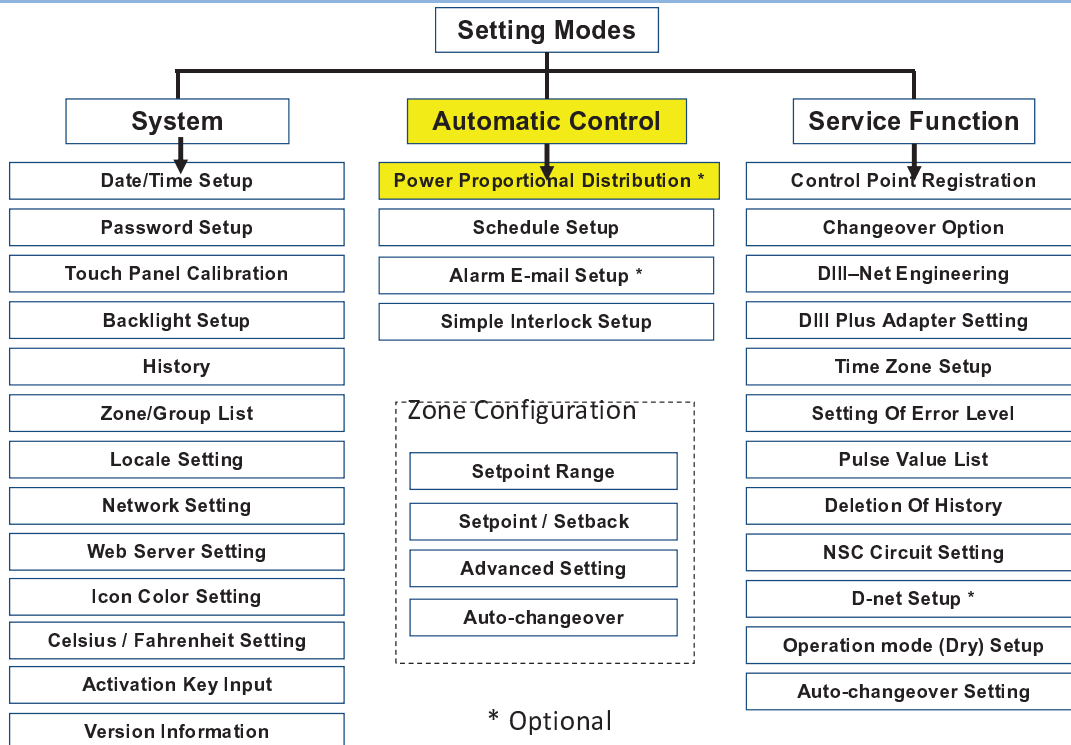
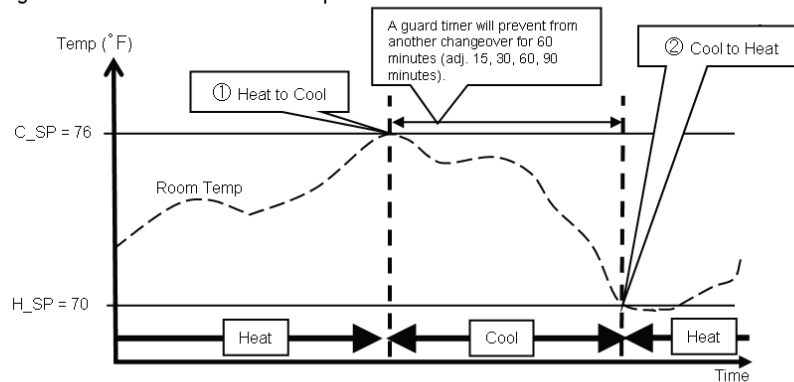

## Power Proportional Distribution (PPD)

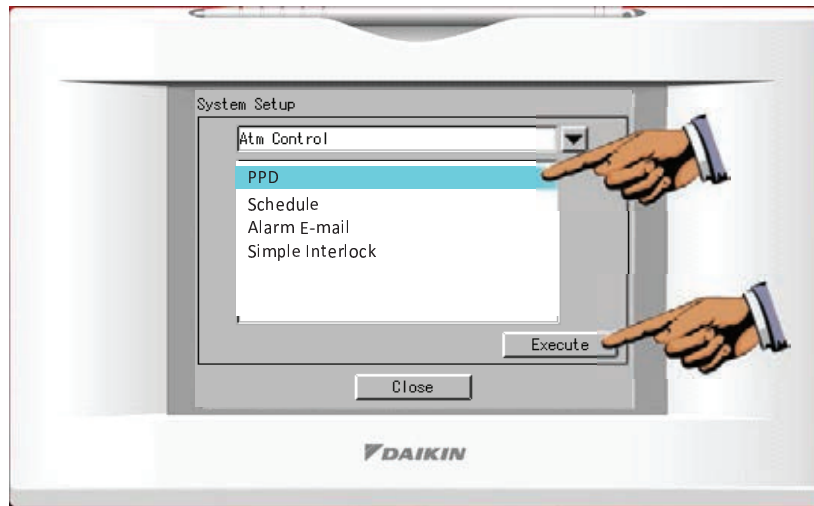

**PPD is available on the list after PPD commissioning**

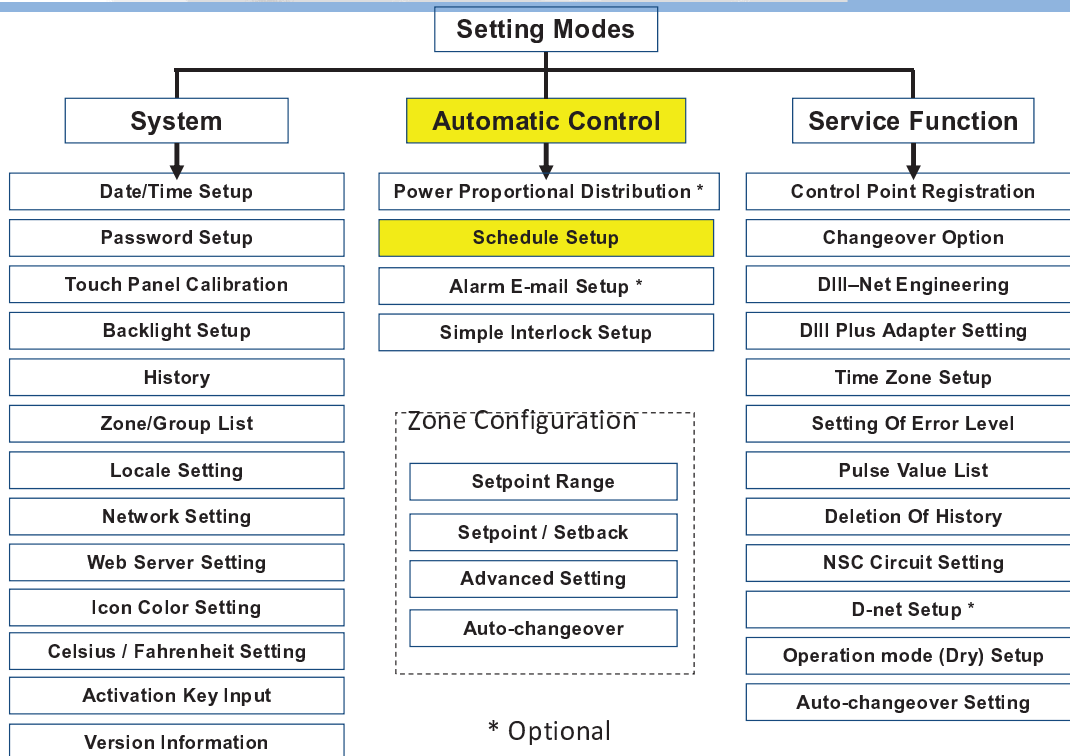



## Schedule Setup

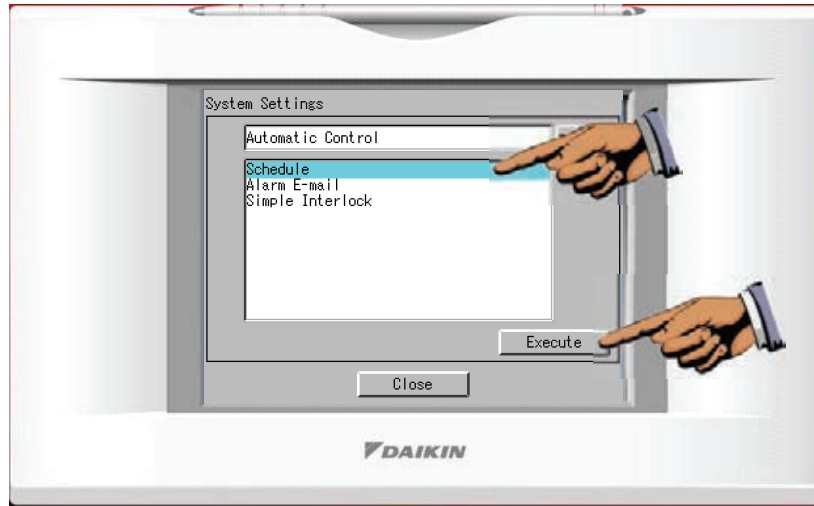

## Schedule Setup

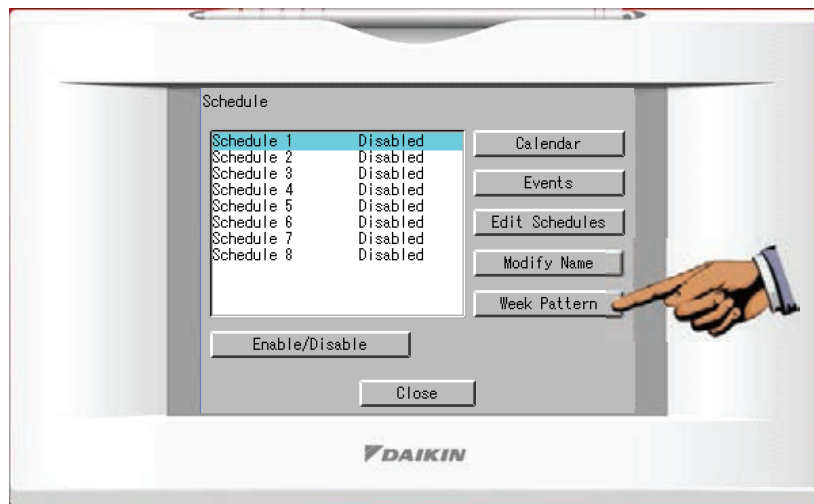

### Schedule Setup

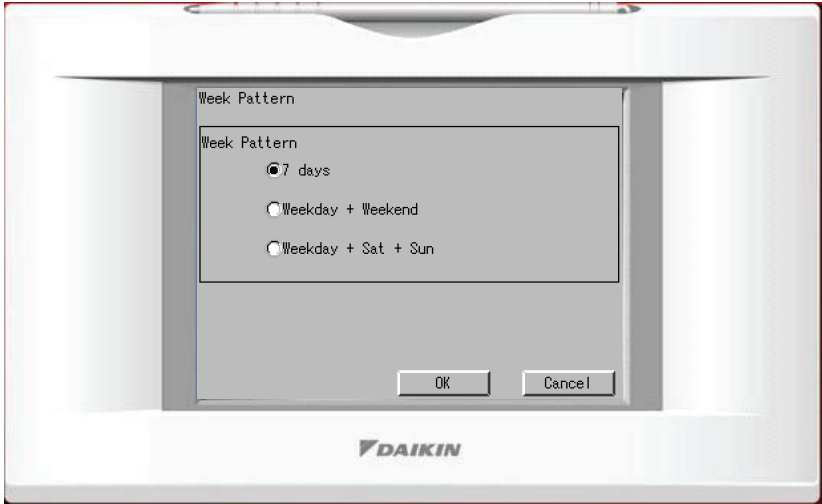

### Schedule Setup

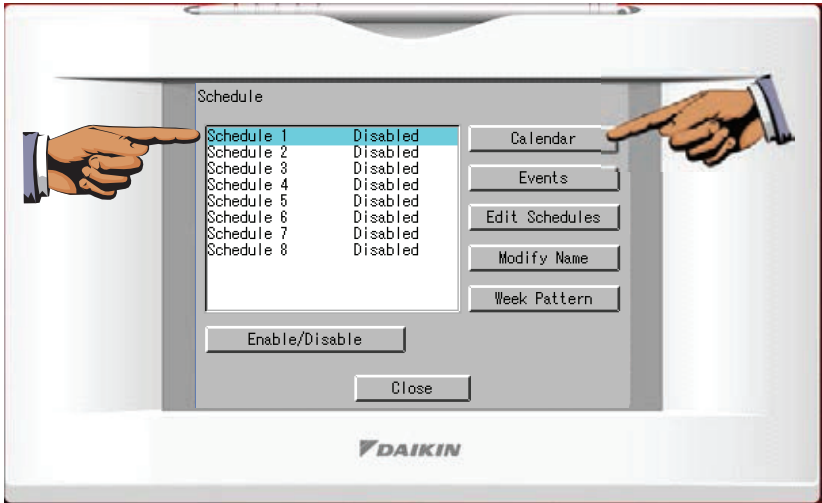

### Schedule Setup

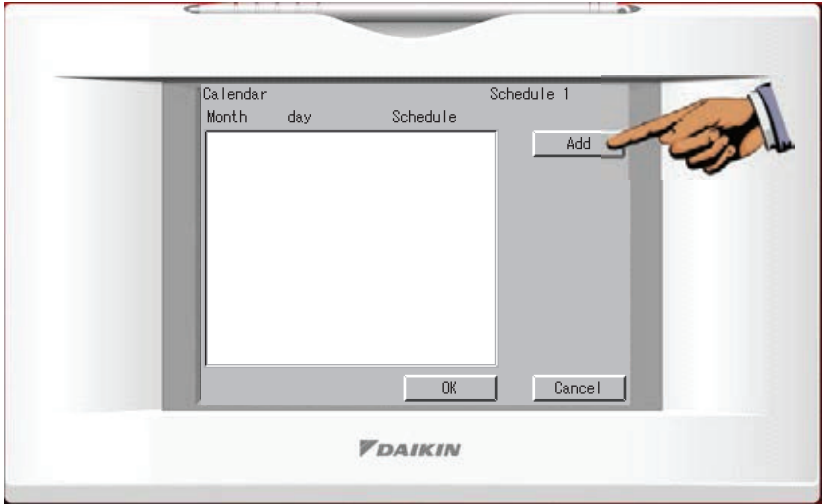

### Schedule Setup

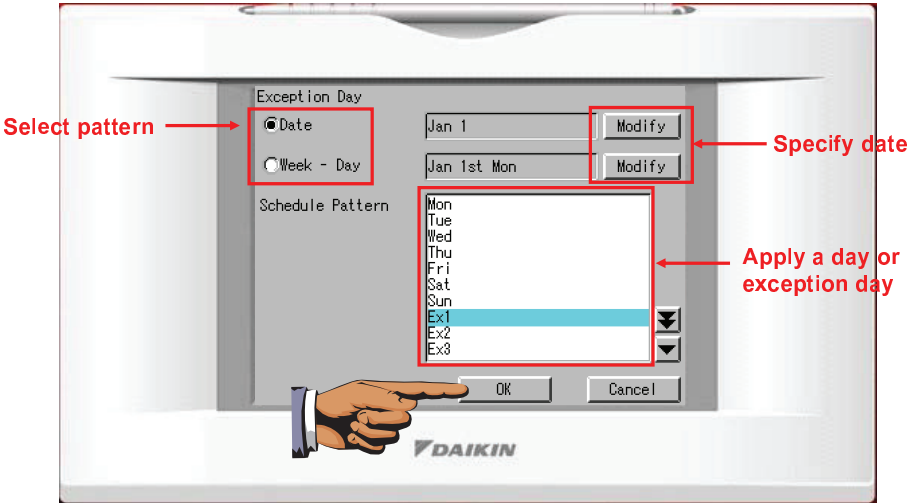

### Schedule Setup

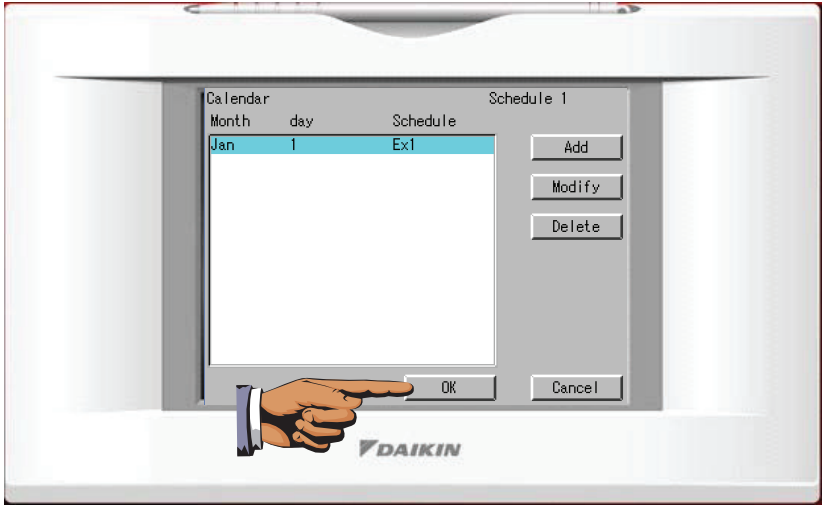

### Schedule Setup



## Schedule Setup

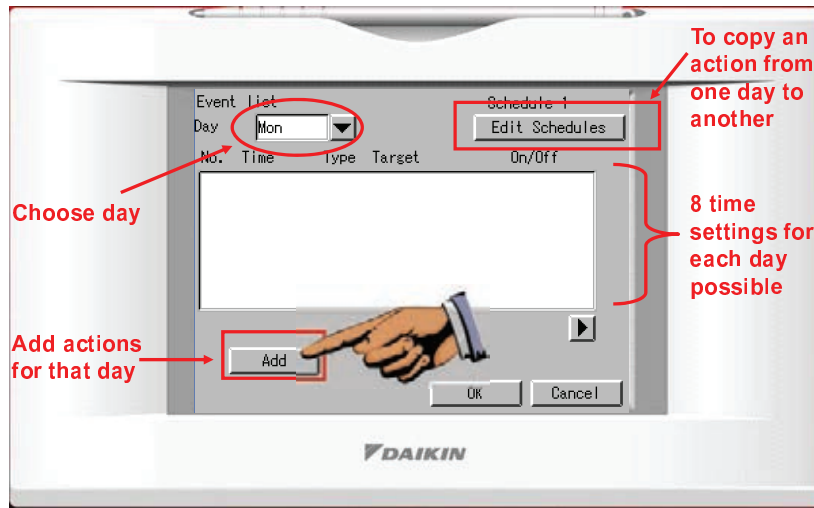

## Schedule Setup

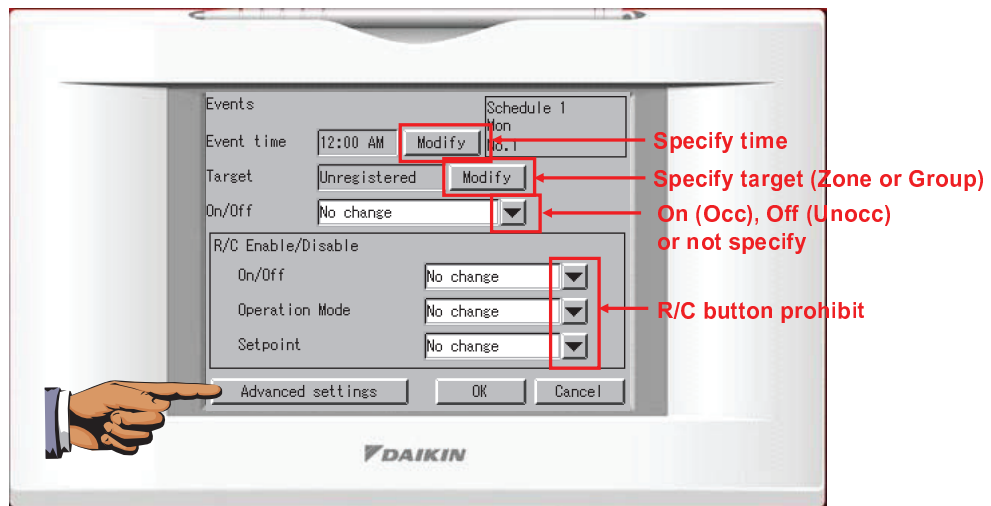

## Schedule Setup

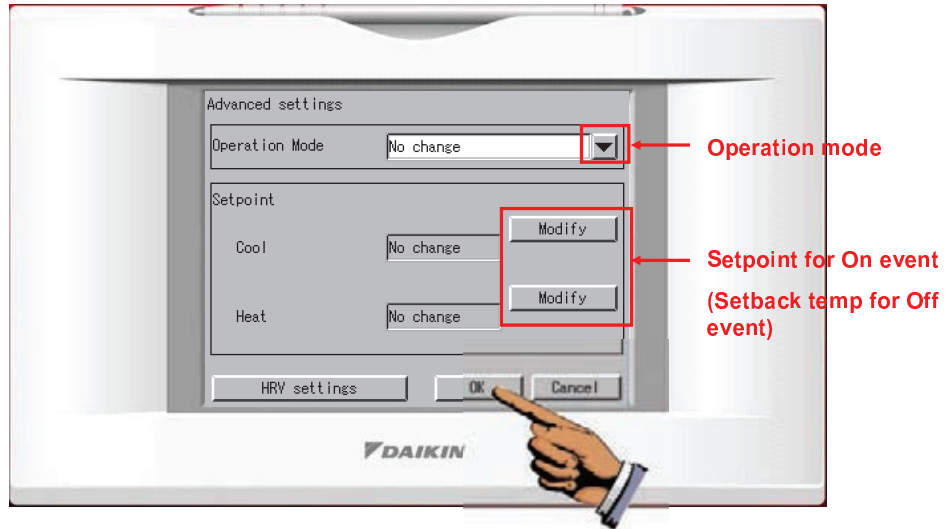

## Schedule Setup

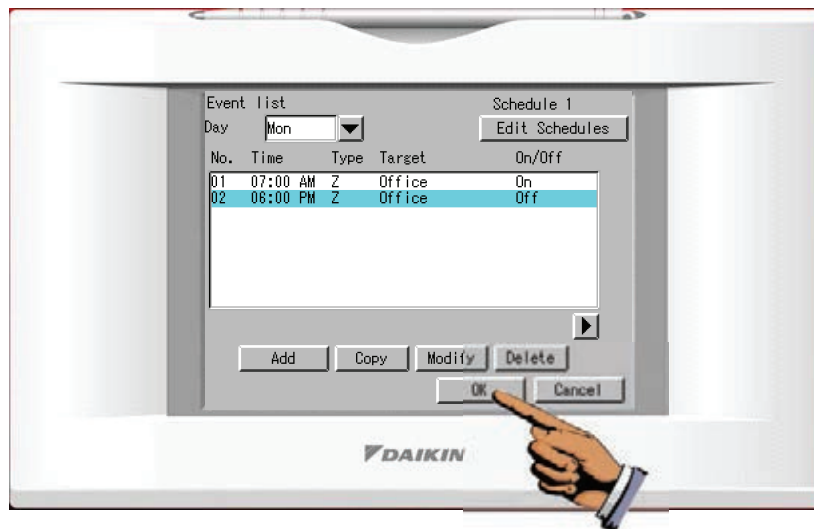

## Schedule Setup

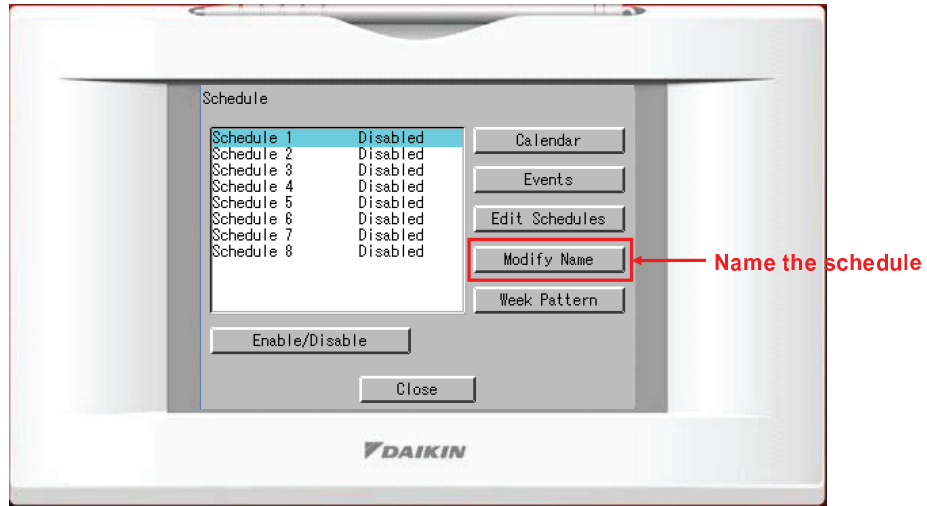

## Schedule Setup

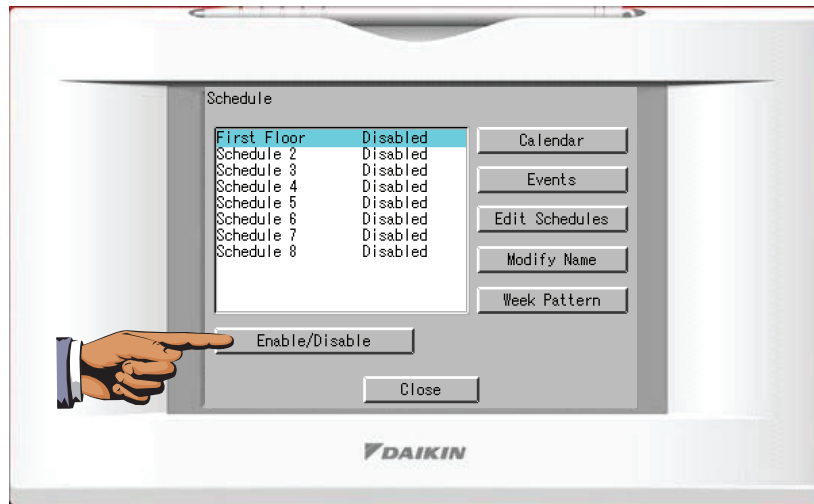

## Schedule Setup

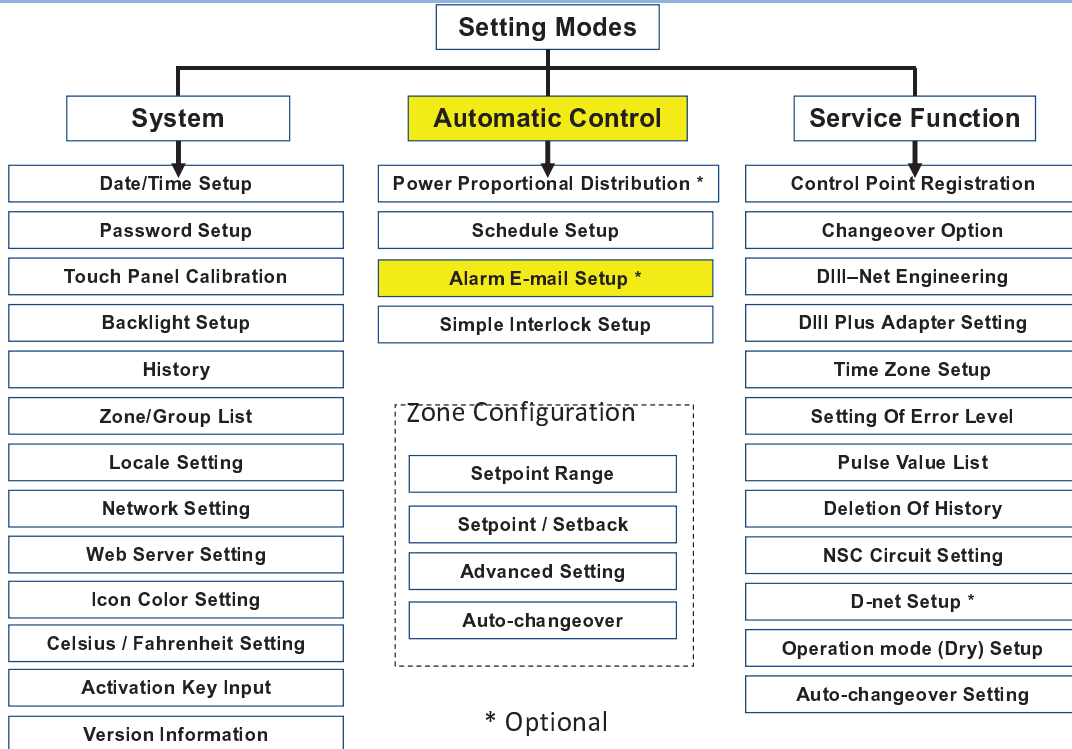
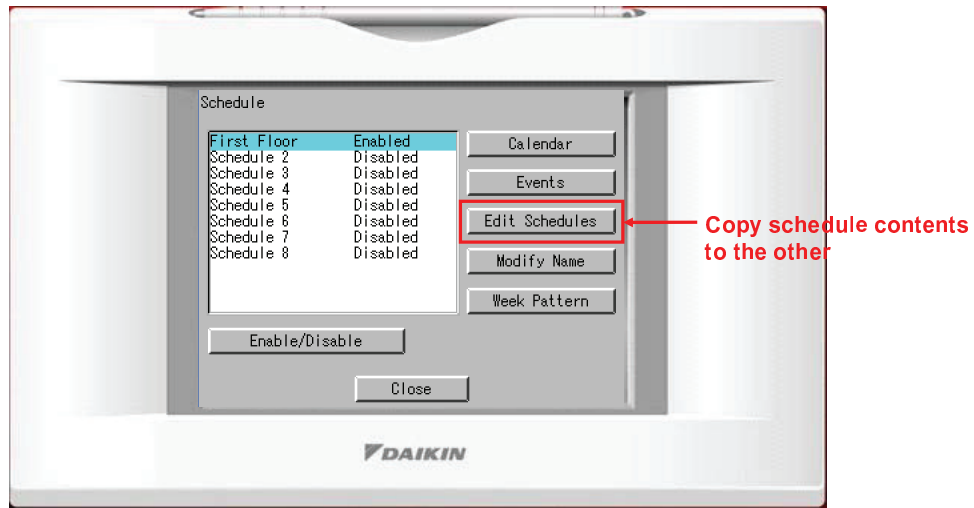



## Alarm E-mail Configuration

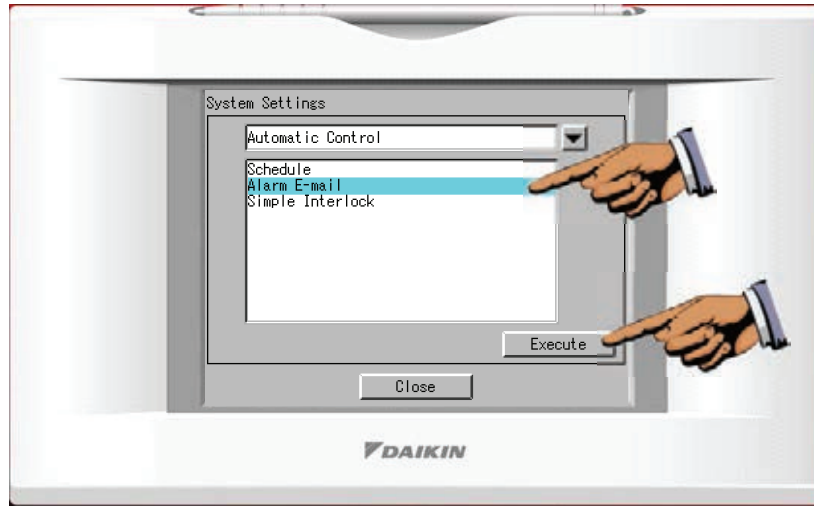

**Alarm E-mail function is available when Web option is activated**

## Alarm E-mail Configuration

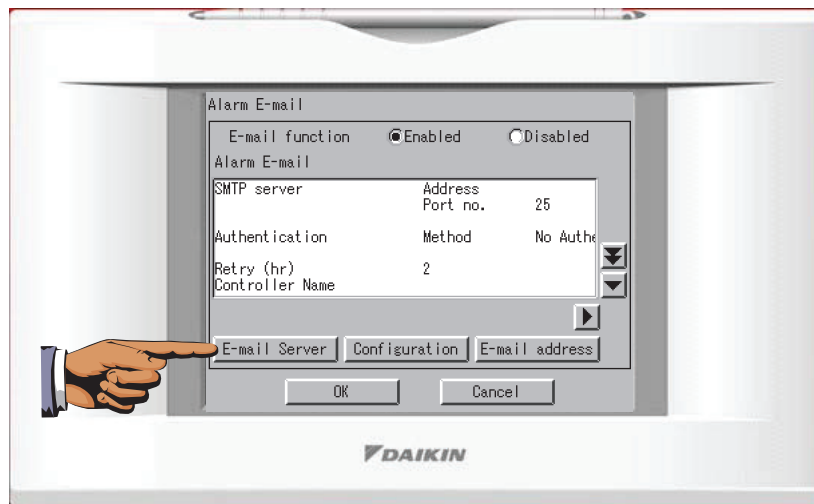

## Alarm E-mail Configuration

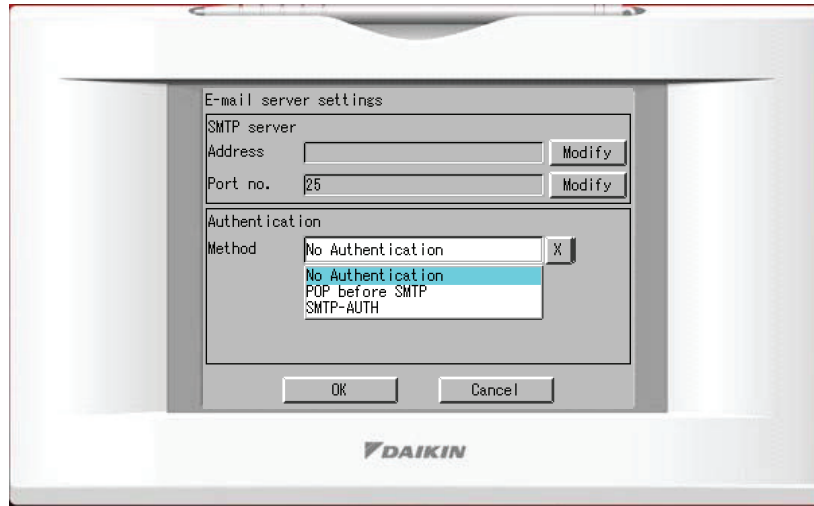

## Alarm E-mail Configuration

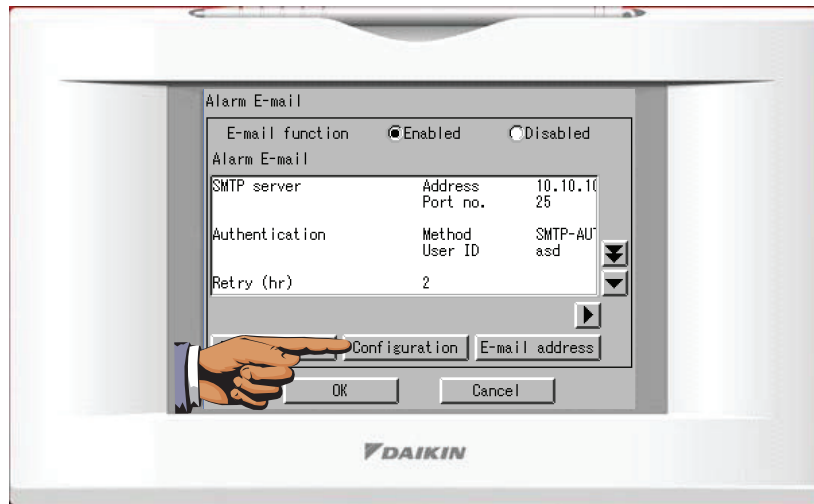

## Alarm E-mail Configuration

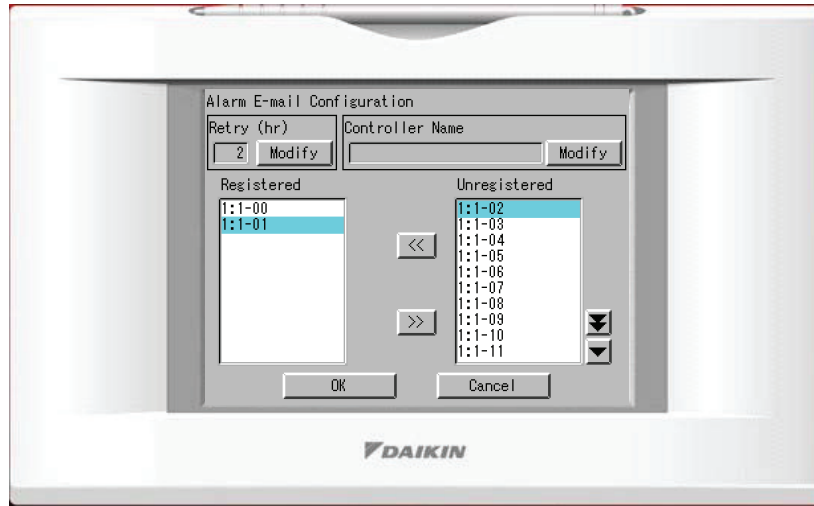

## Alarm E-mail Configuration

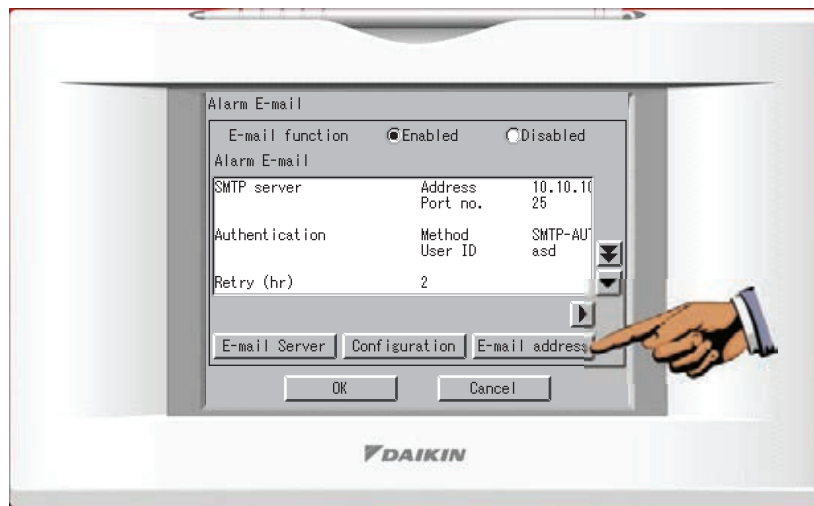

## Alarm E-mail Configuration

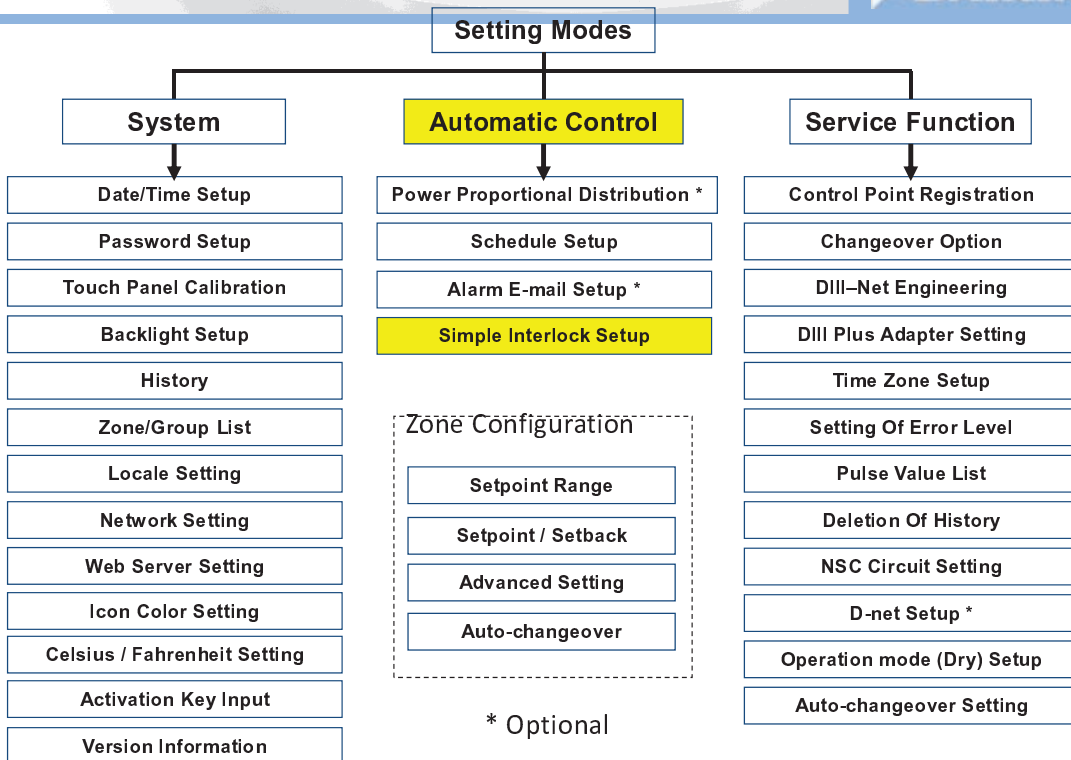
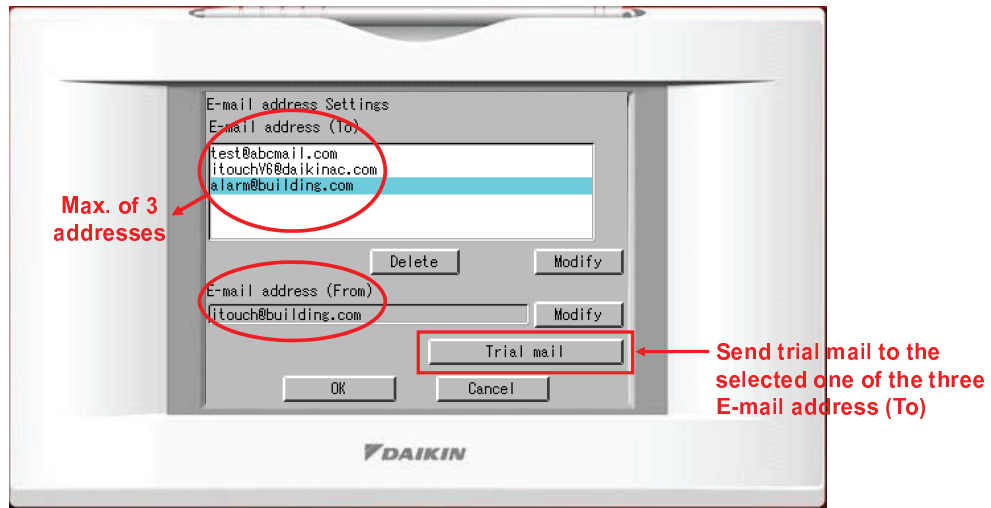

# iTouch Interlock Function



## Monitor and Control ancillary equipment via Interlock

- Create an interlock to start and stop a outside air unit serving Daikin indoor units
  - The following example requires the outside air fan to operate while at least one of several Daikin indoor unit is in operation.
    - FIRST CONDITION: WHEN EITHER 1-00 OR 1-01 IS TURNED ON, 1-02 (OA FAN) WILL BE STARTED
    - SECOND CONDITION: WHEN BOTH 1-00 AND 1-01 ARE TURNED OFF, 1-02 (OA FAN) WILL BE STOPPED

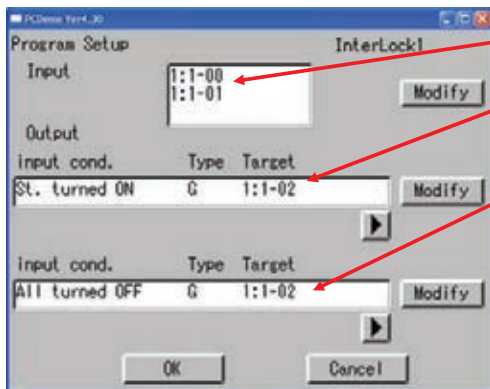

Daikin indoor units served by the outside air fan.

Instruction to start OA fan when either indoor units 1-00 or 1-01 are started.

Instruction to stop the OA fan when all registered units are stopped.



## Simple Interlock Setup

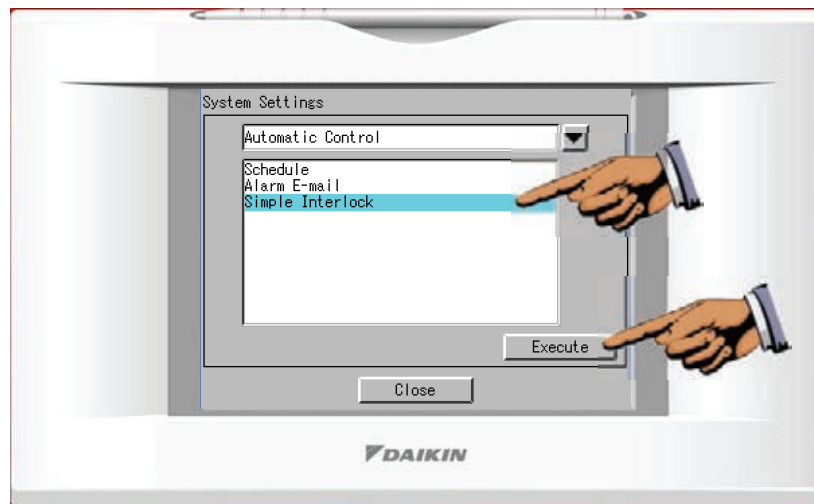

## Simple Linkage Setup

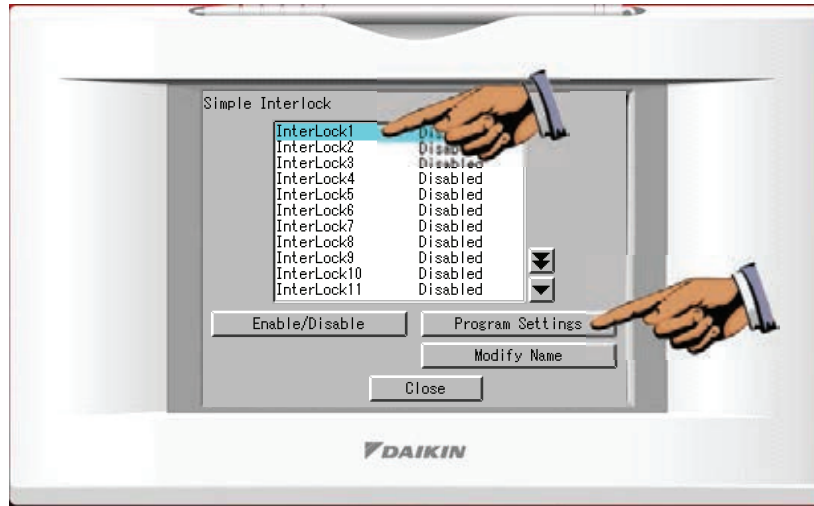

## Simple Interlock Setup

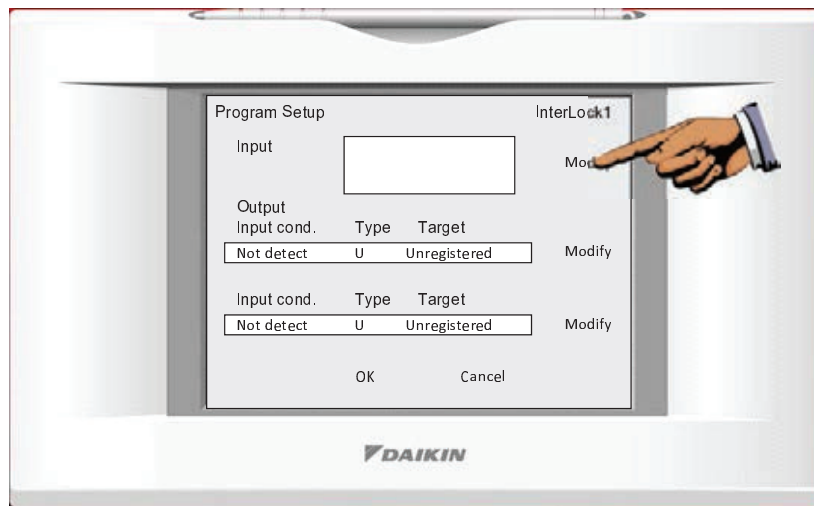

### Simple Interlock Setup

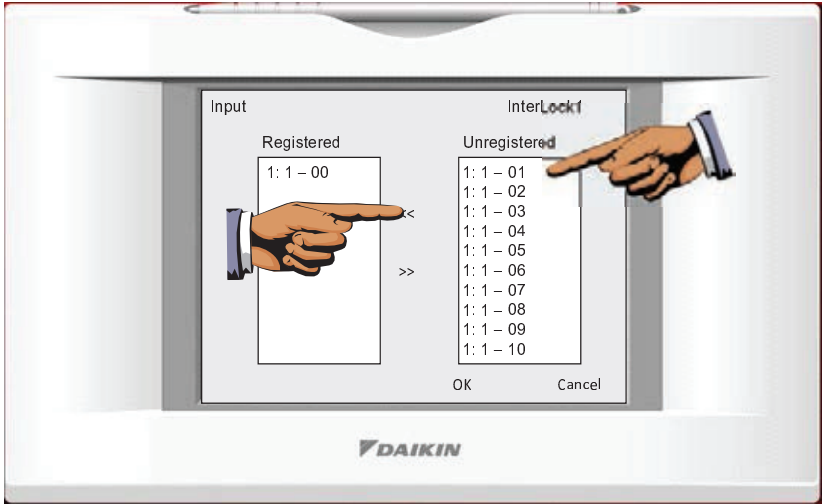

### Simple Interlock Setup

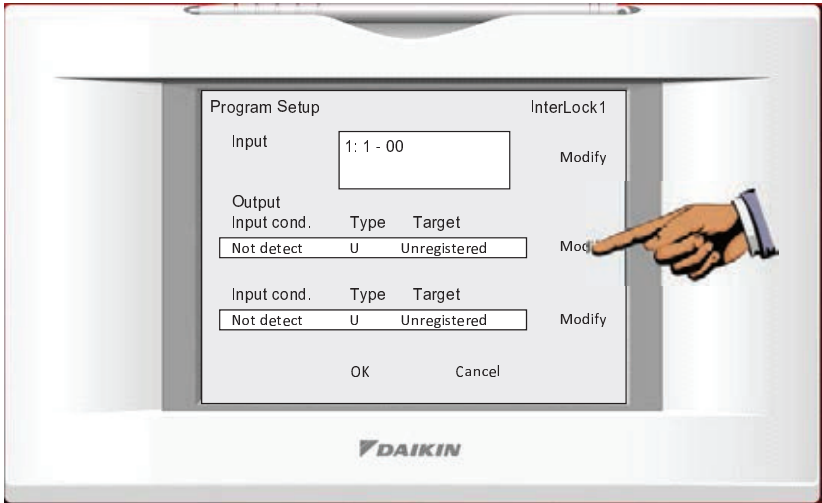

### Simple Interlock Setup



### Simple Interlock Setup





### Simple Interlock Setup

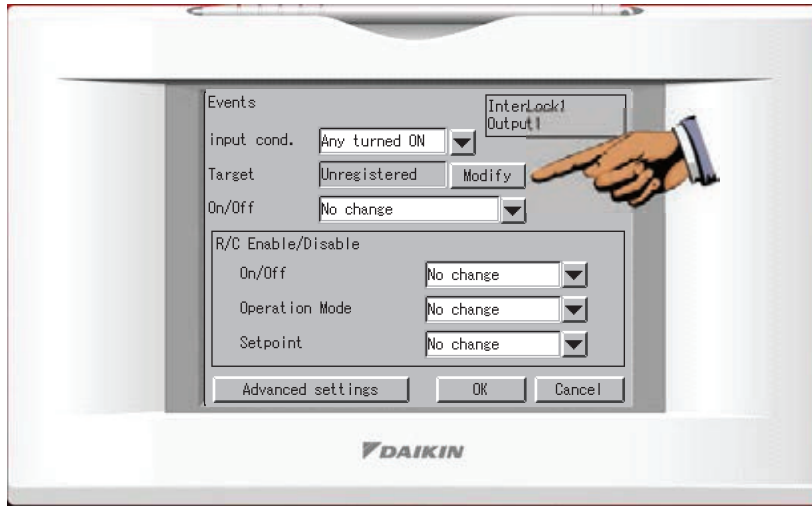

### Simple Interlock Setup

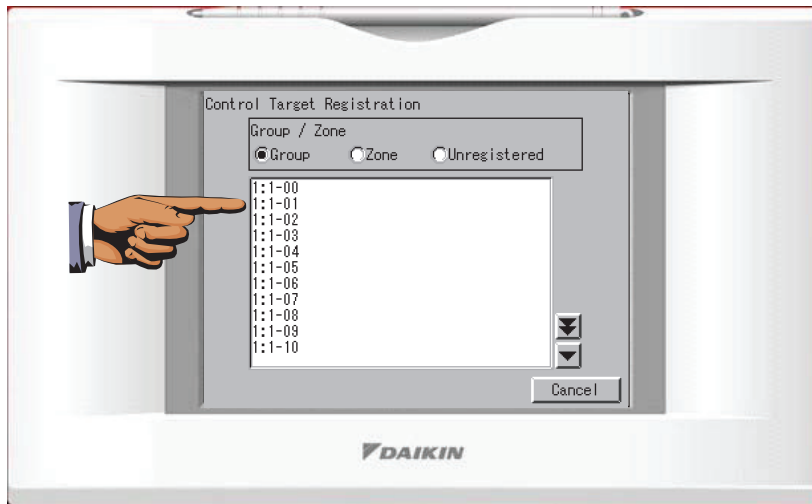

### Simple Interlock Setup



### Simple Interlock Setup

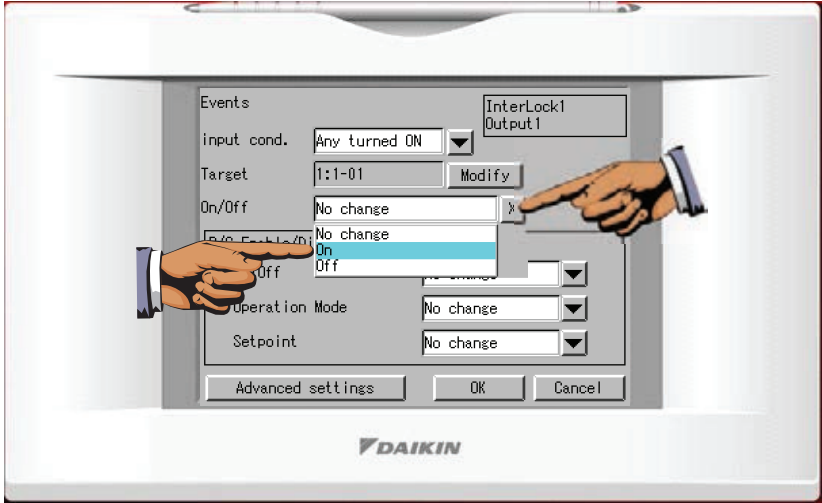

### Simple Interlock Setup



### Simple Interlock Setup

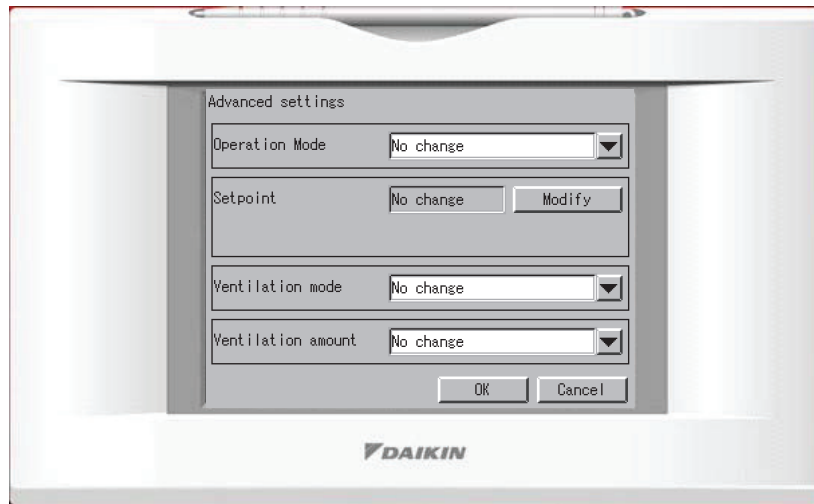

## Simple Interlock Setup

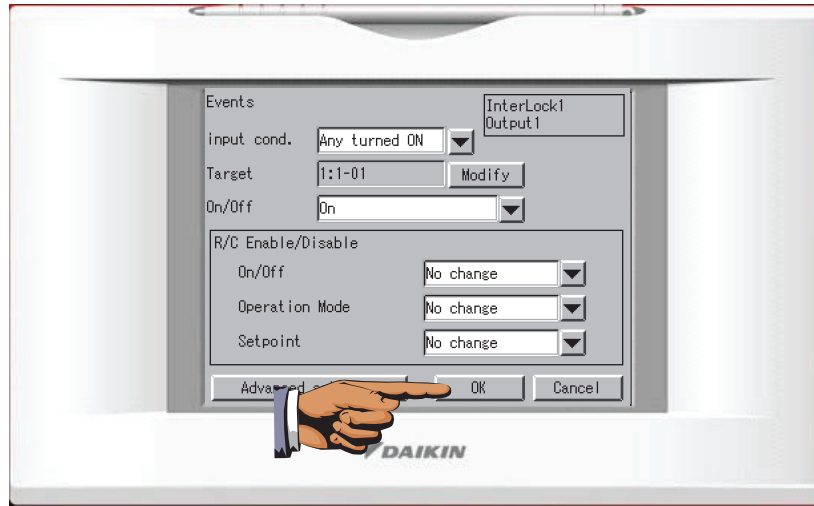

## Simple Interlock Setup

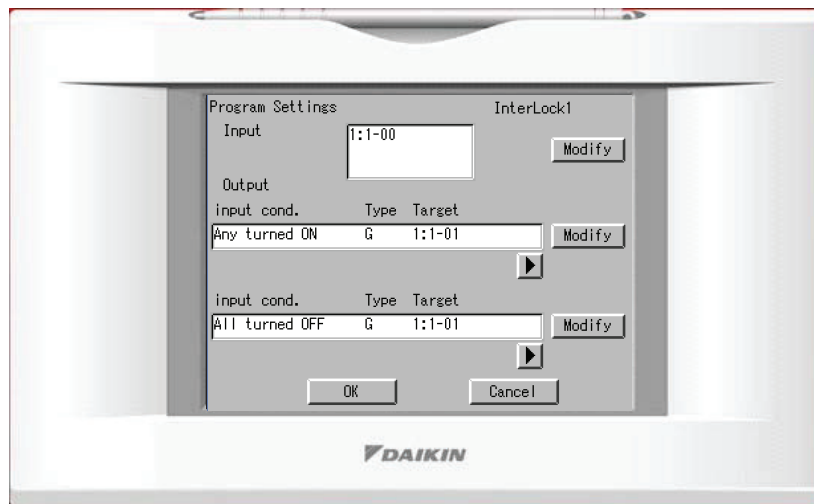

## Simple Interlock Setup

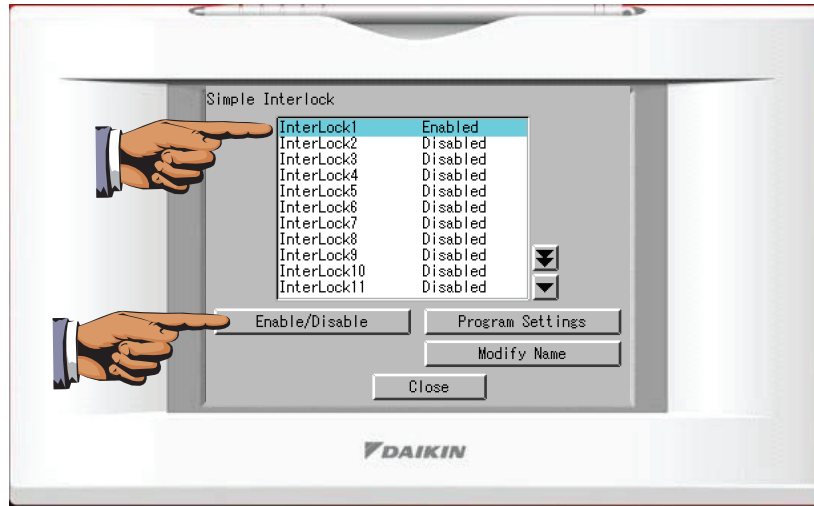

## Simple Interlock Setup

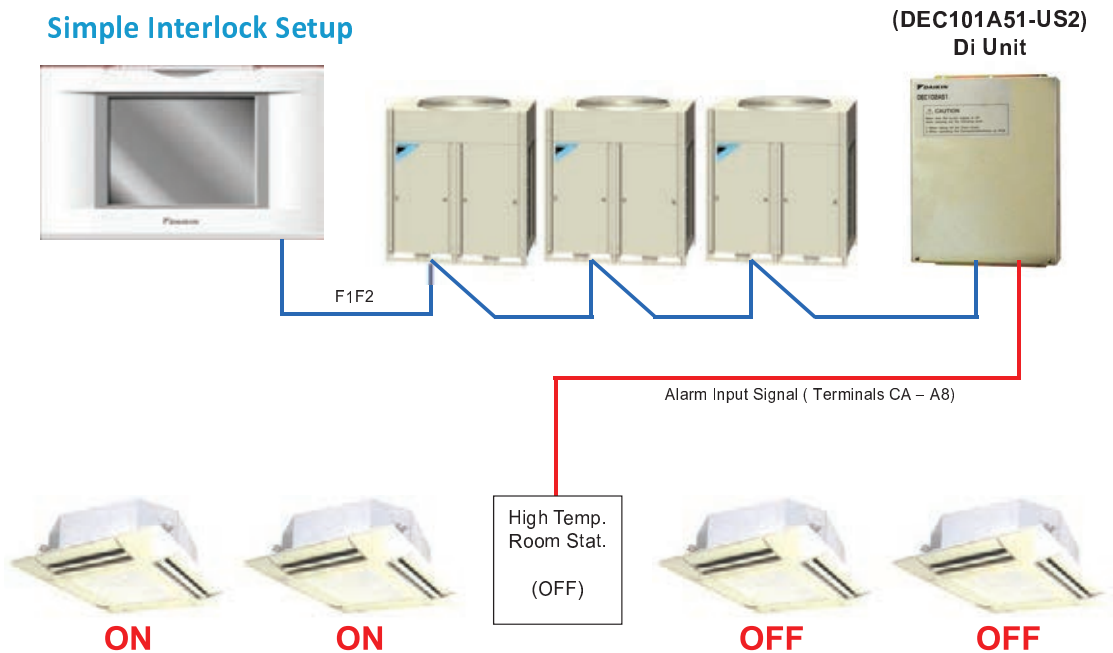

### Simple Interlock Setup

(DEC101A51-US2)  
Di Unit

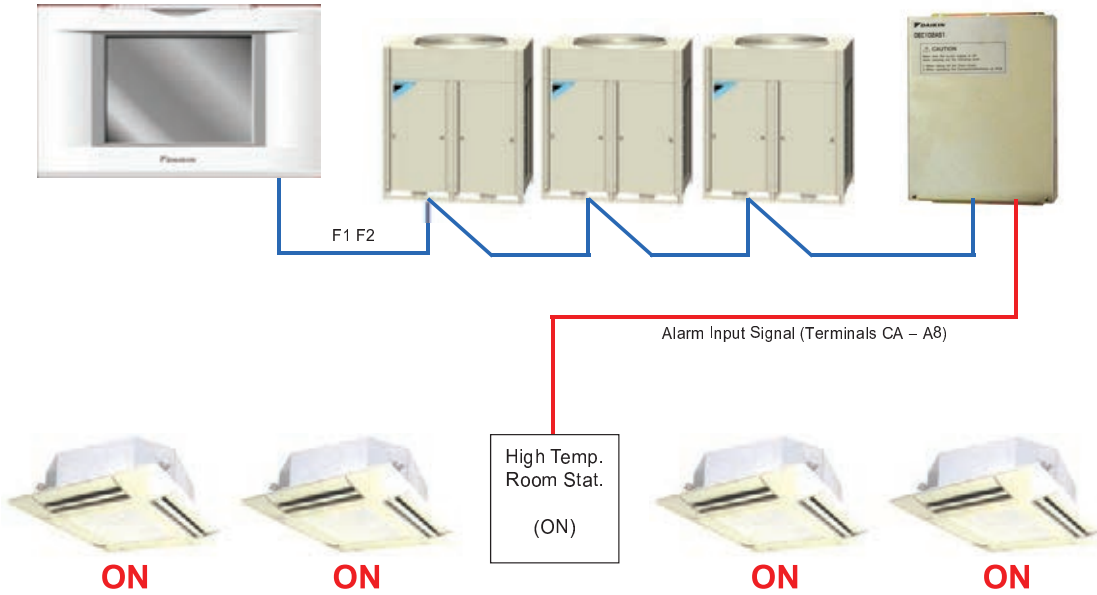

### Simple Interlock Setup

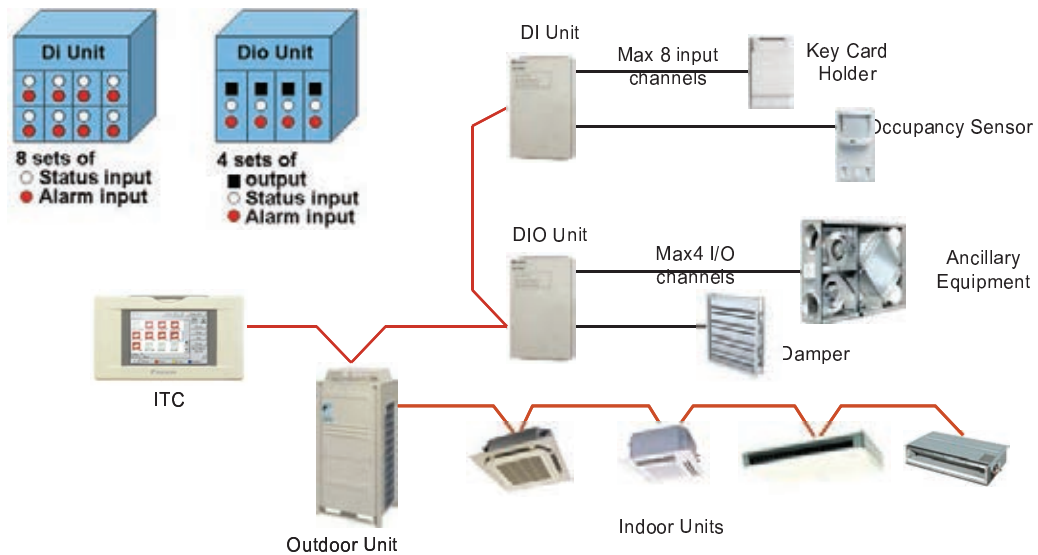

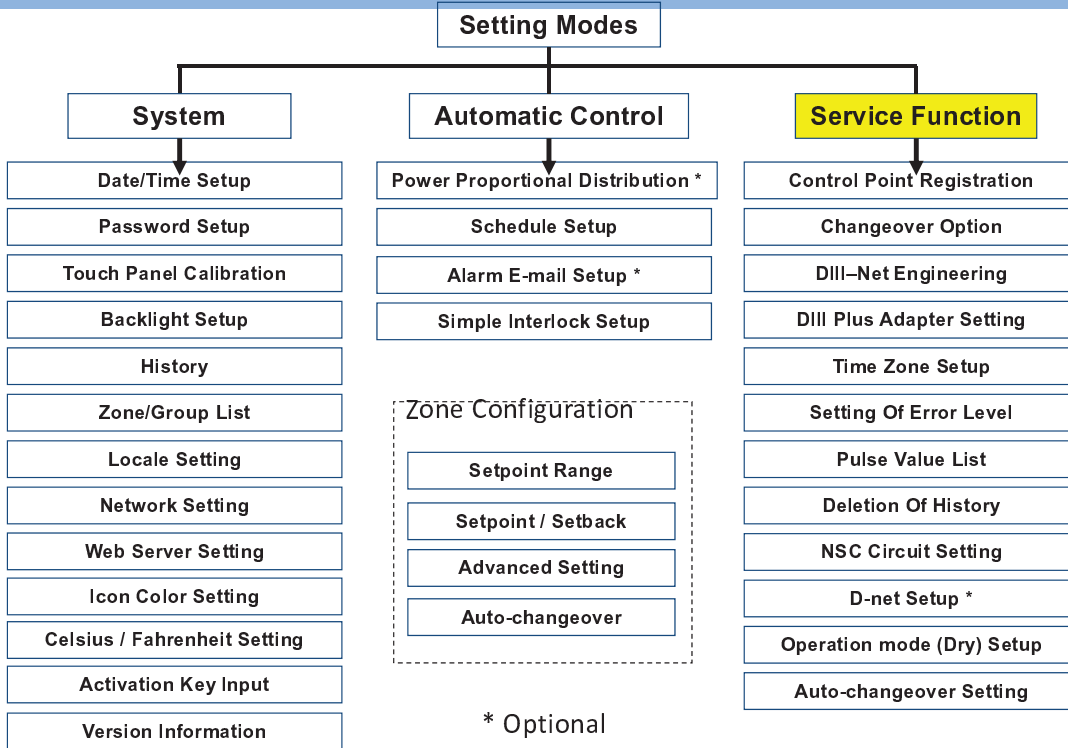

### How To Access The Service Function Menu

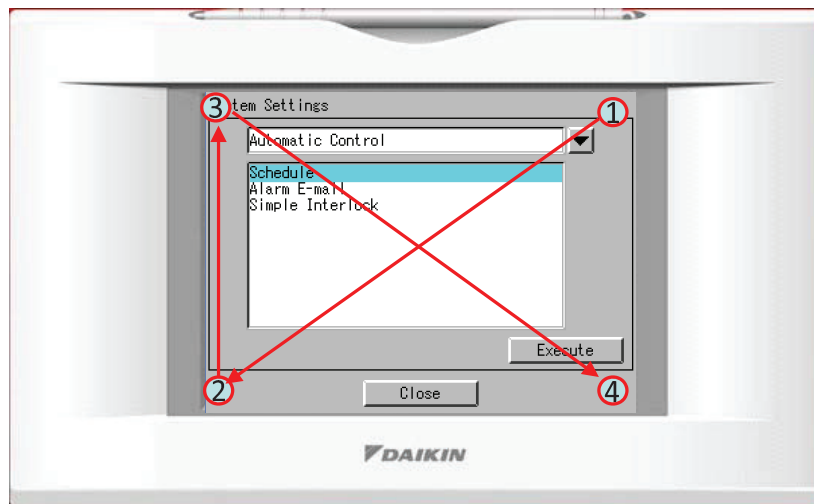

## How To Access The Service Function Menu

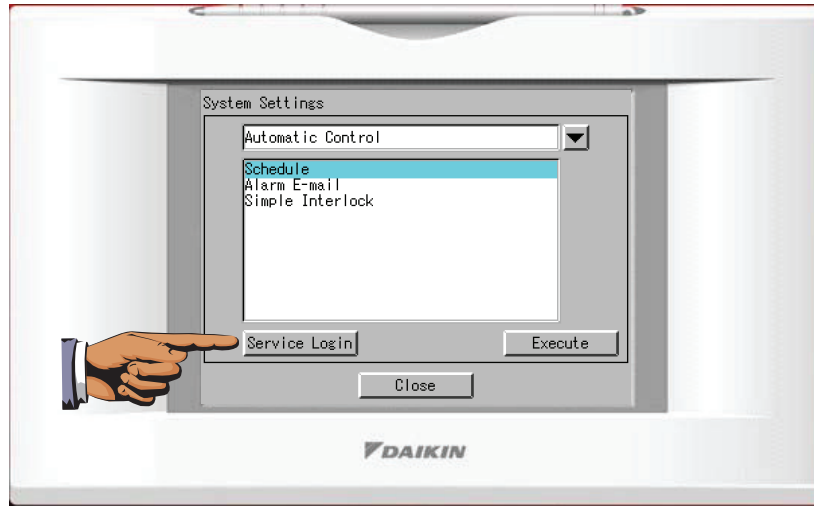

## How To Access The Service Function Menu





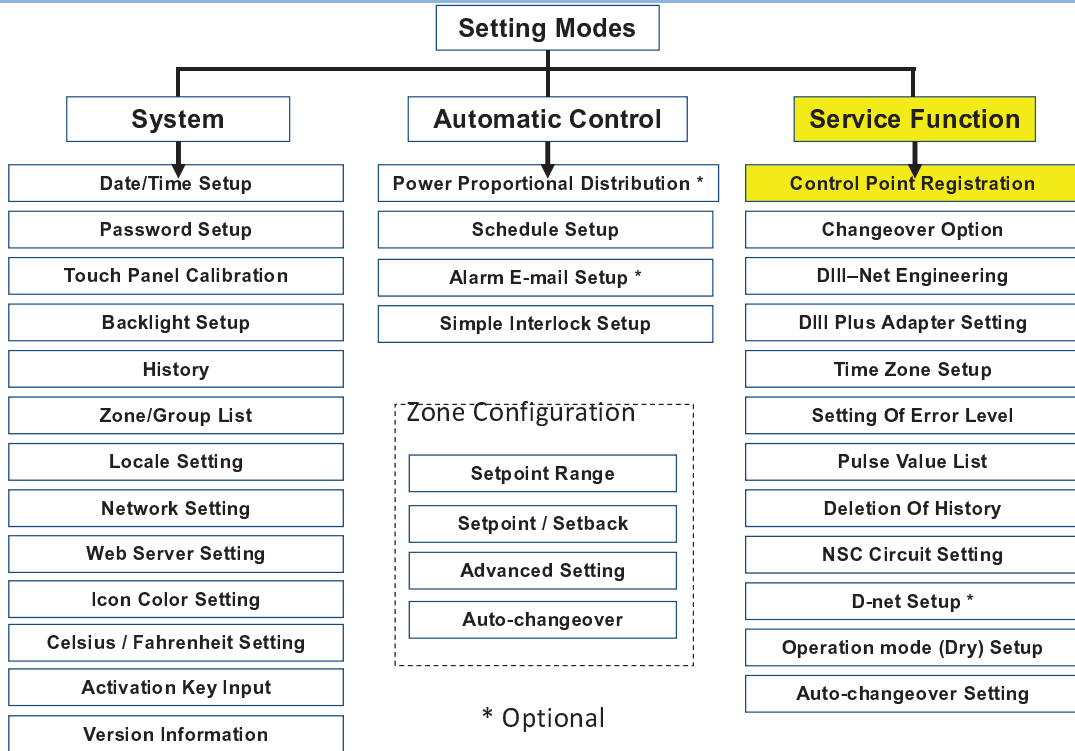

## Control Point Registration

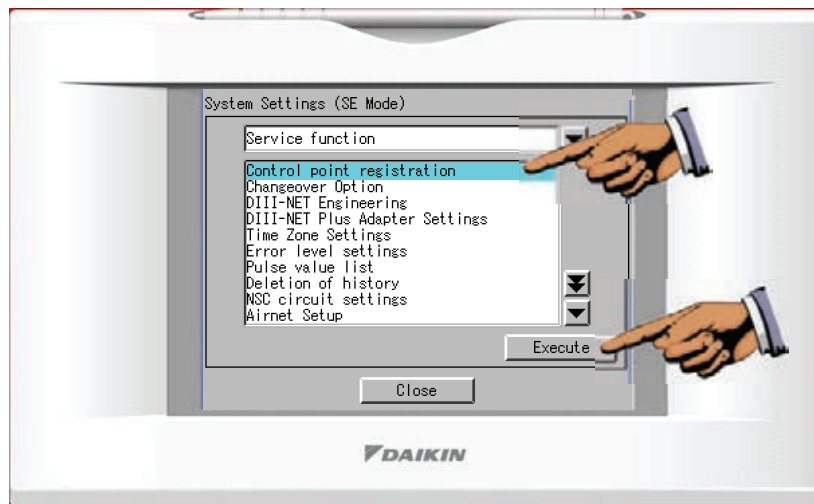

## Control Point Registration

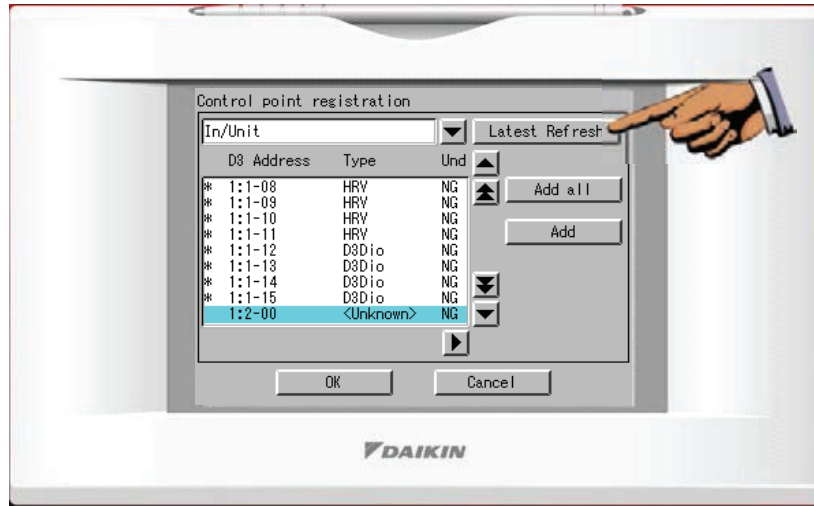

## Control Point Registration

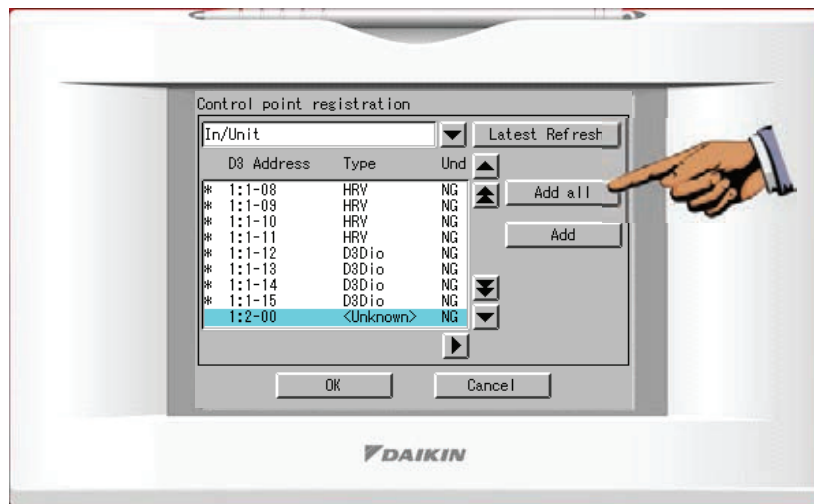

## Control Point Registration

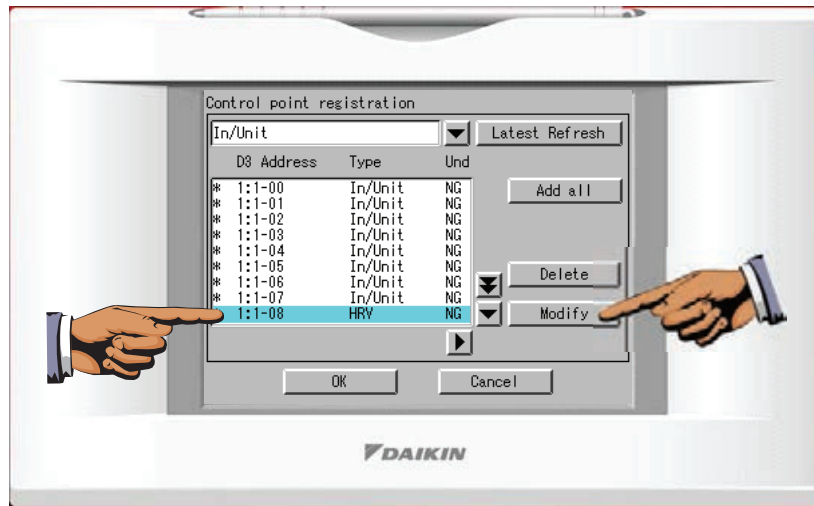

## Control Point Registration

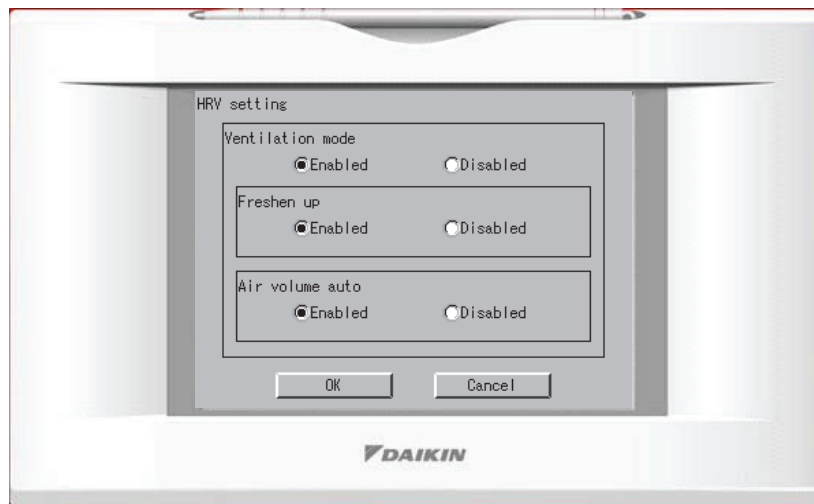

## Control Point Registration



**DO NOT USE!**

## Control Point Registration

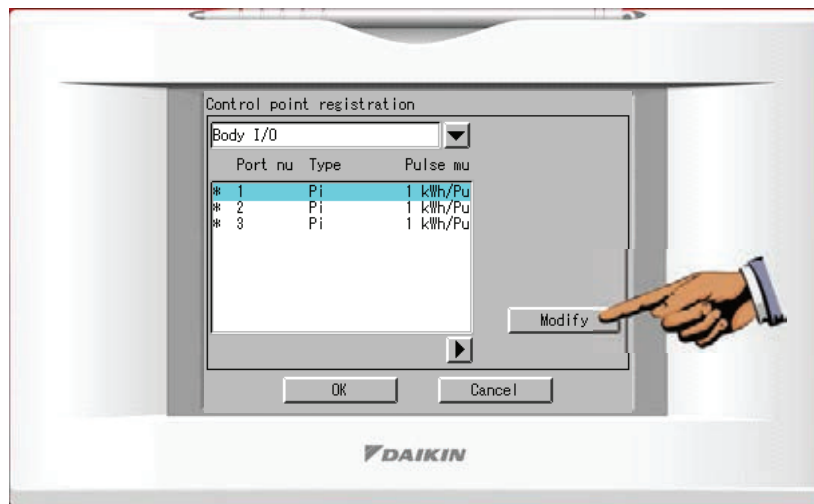

## Control Point Registration

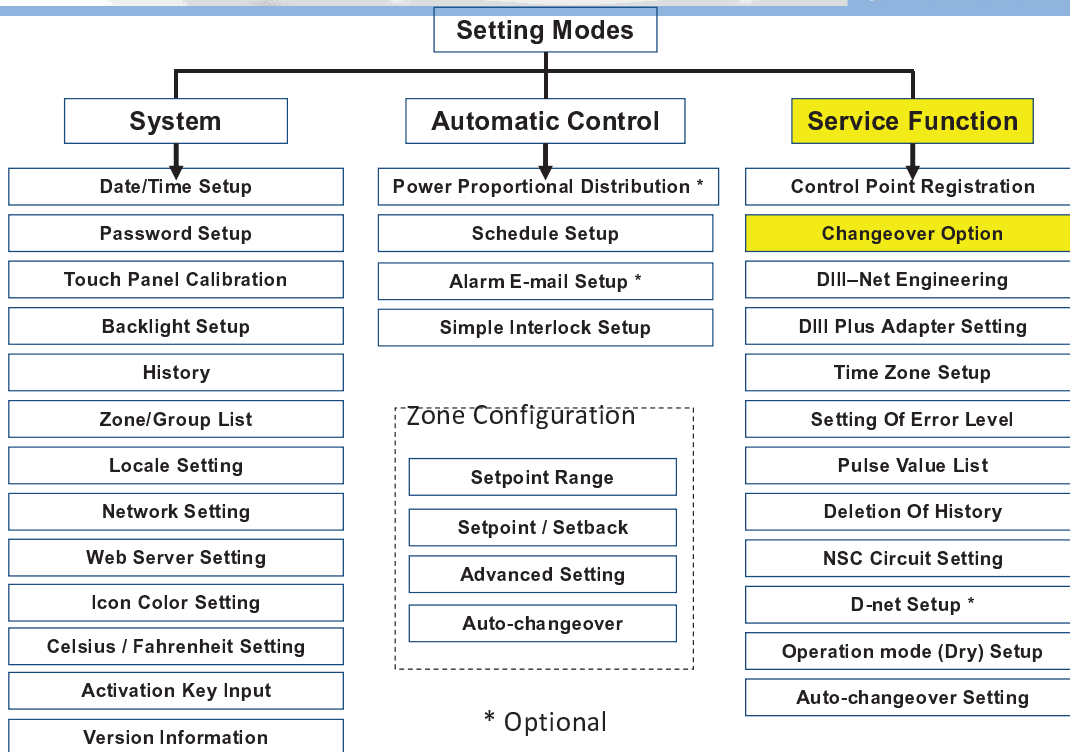

## Changeover Option

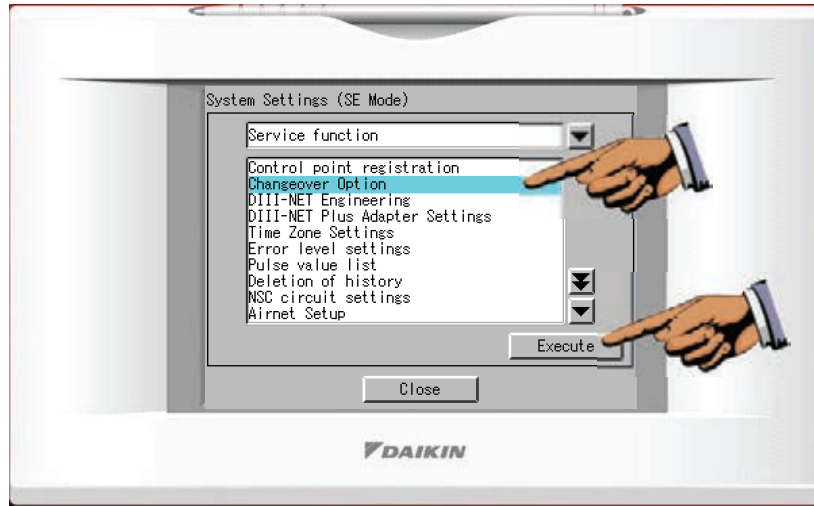

## Changeover Option (if indoor unit group is a master of Changeover)



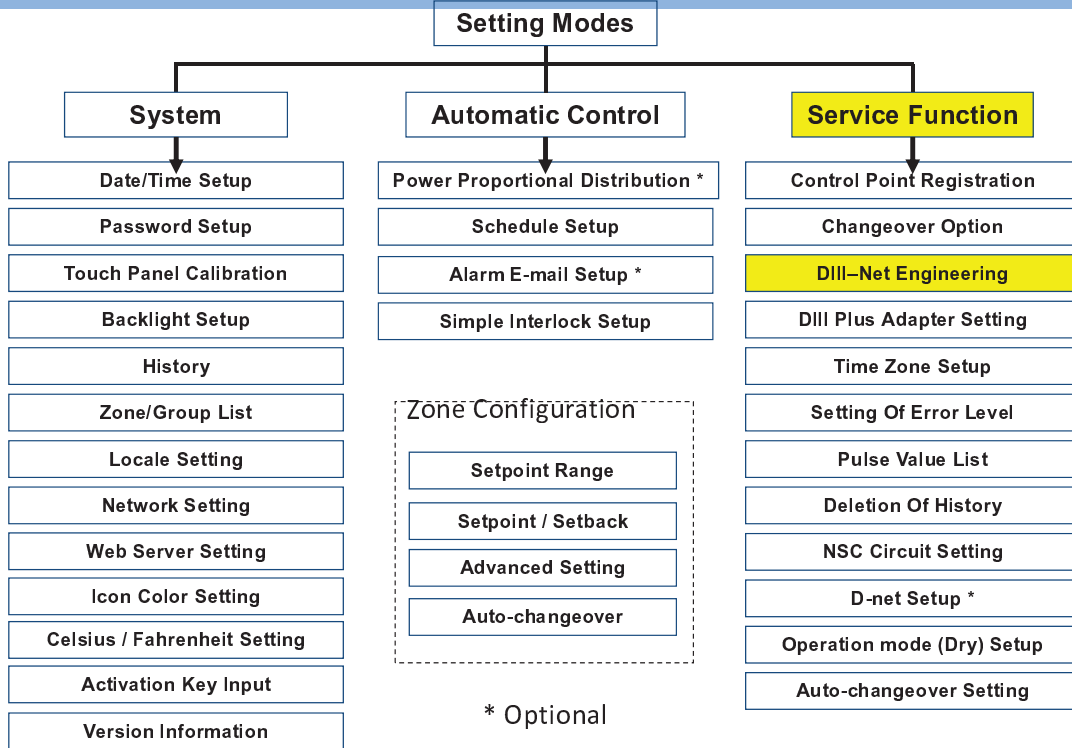

## DIII-Net Engineering

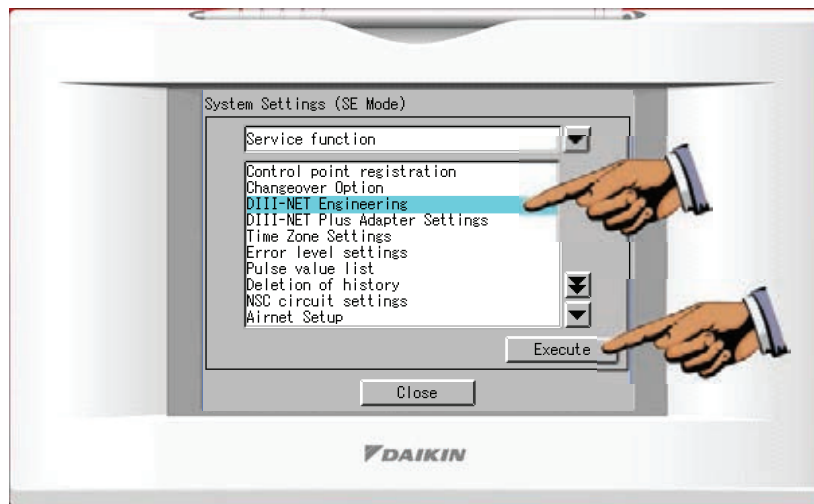

## DIII-Net Engineering

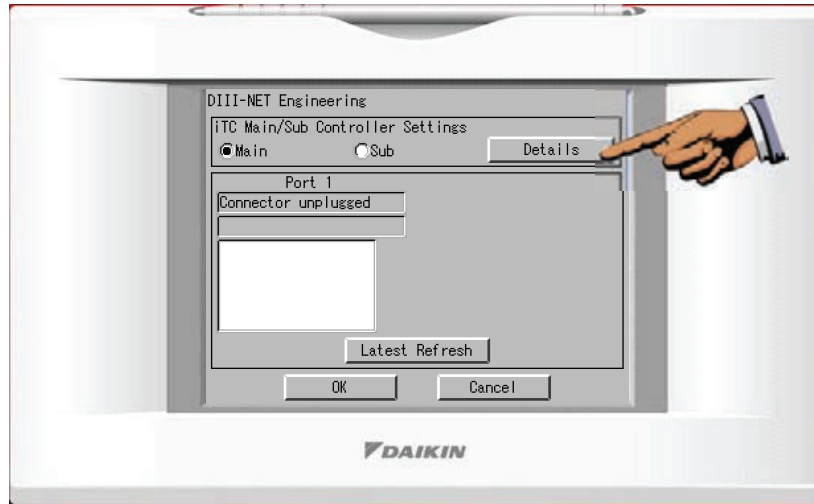

**When two ITC's are connected to the same F1F2 wiring loop (DIII-Net line), one of the controllers must be made in to a sub controller**

## DIII-Net Engineering



**With Enabled, Setpoint Range Limitation would be available on iTouch Controller even when there is a higher level controller connected to the DIII-Net system such as the BACnet / LON Interfaces**



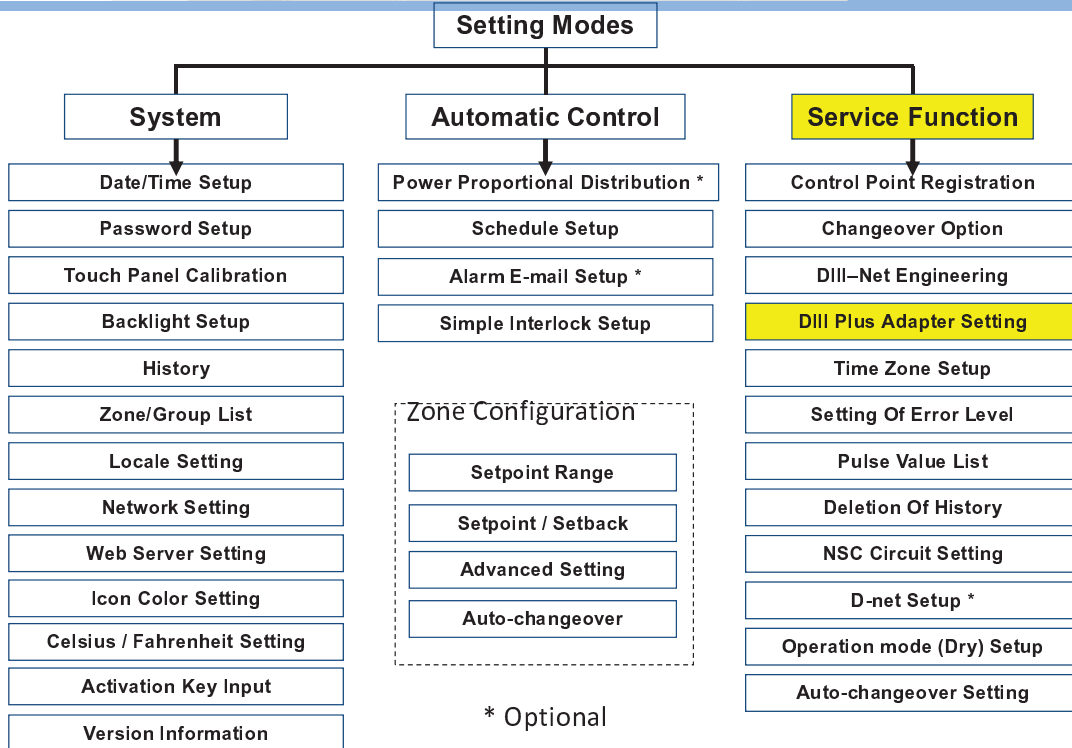

## DIII Plus Adapter Setting

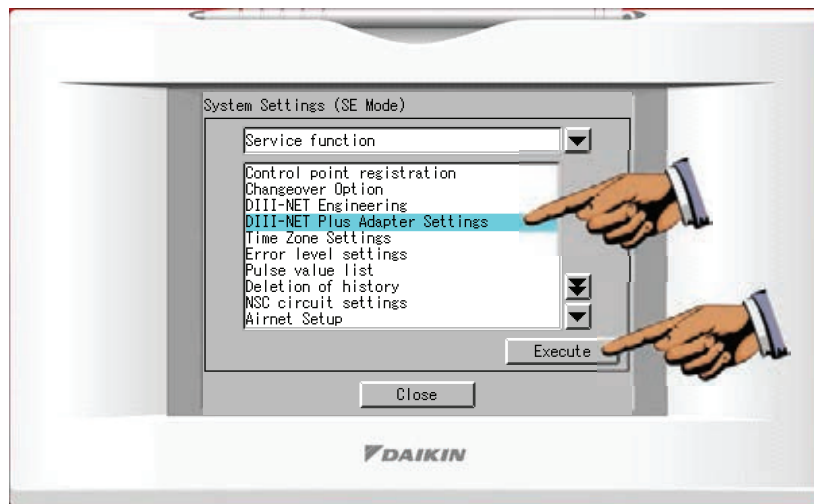

## DIII Plus Adapter Setting

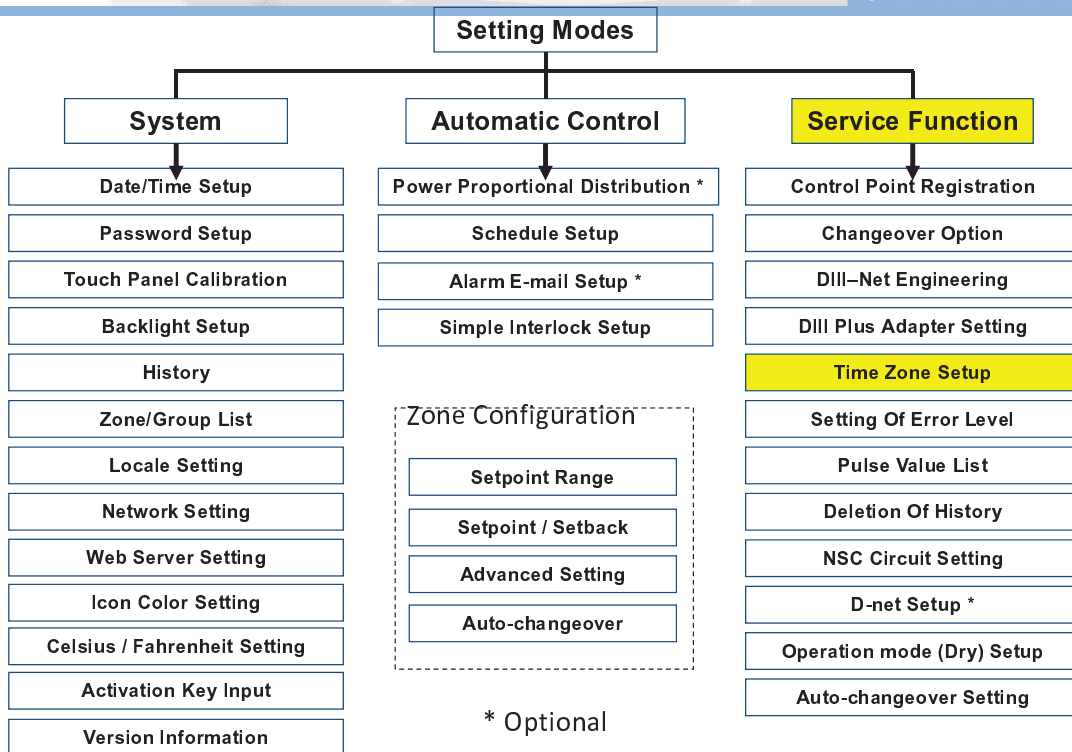

## Time Zone Setup



## Time Zone Setup

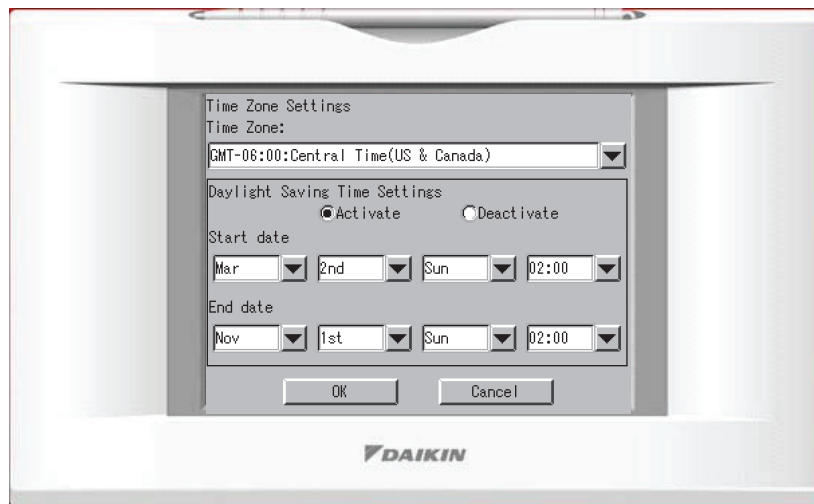

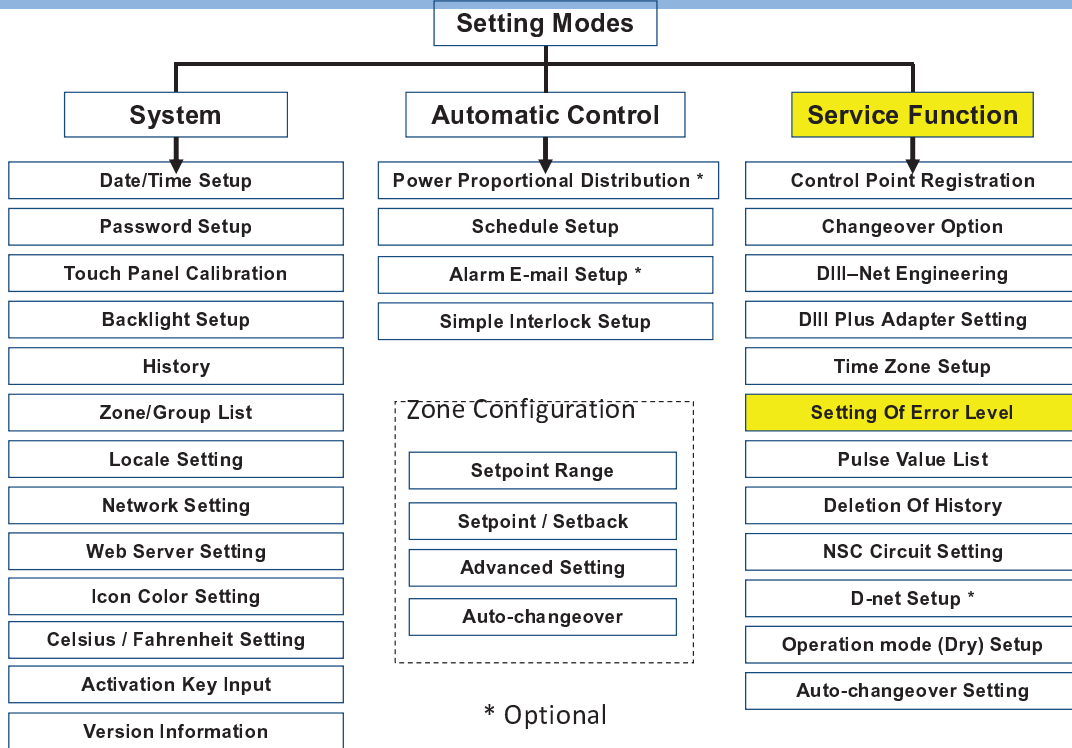

## Setting Of Error Level

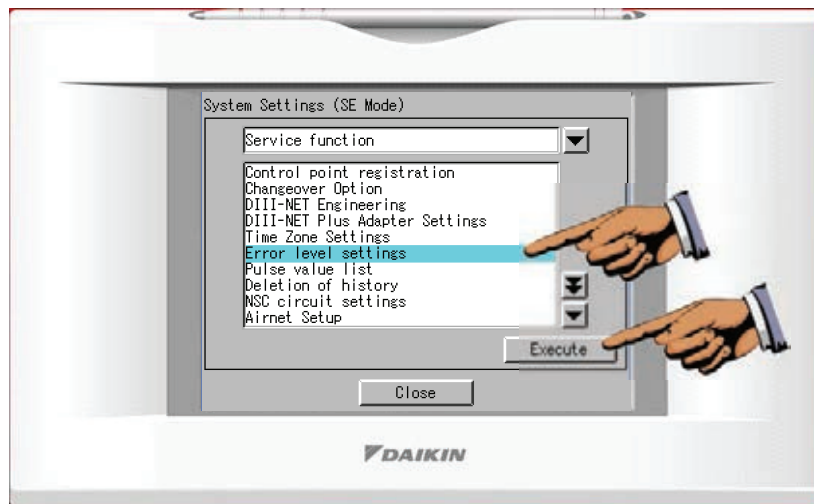

## Setting Of Error Level

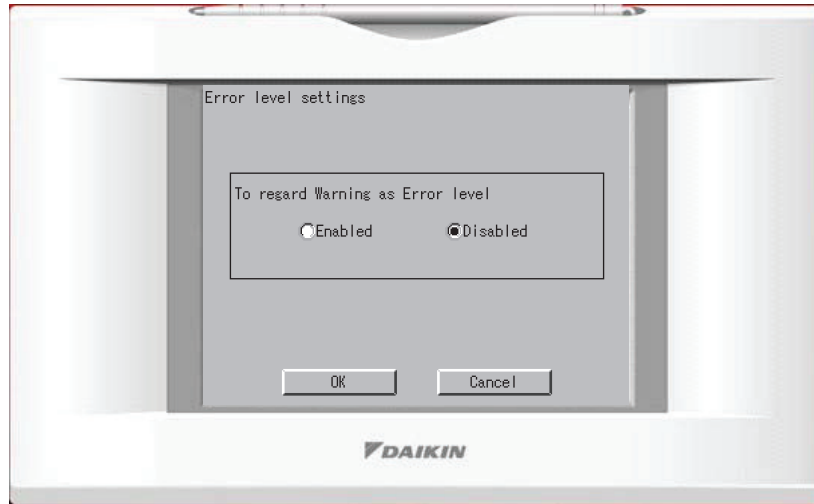

This can be set in the case where an error occurs that does not stop the units operation (A7). We can decide as to whether the fault is displayed on the ITC or not

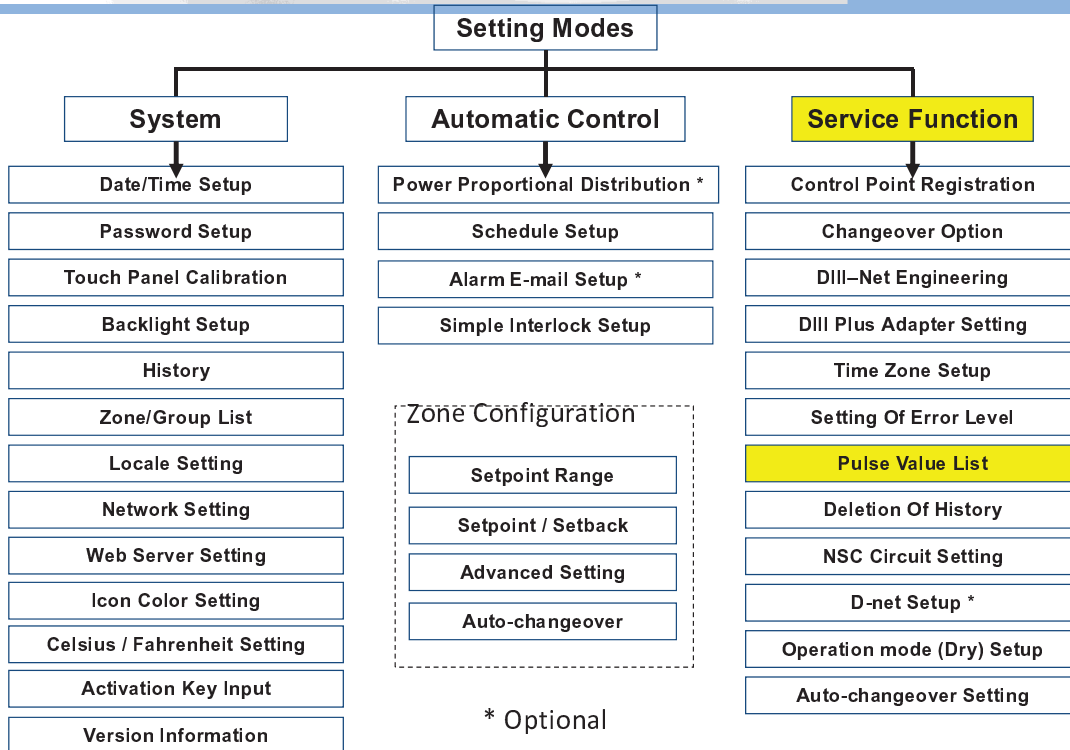

## Pulse Value List

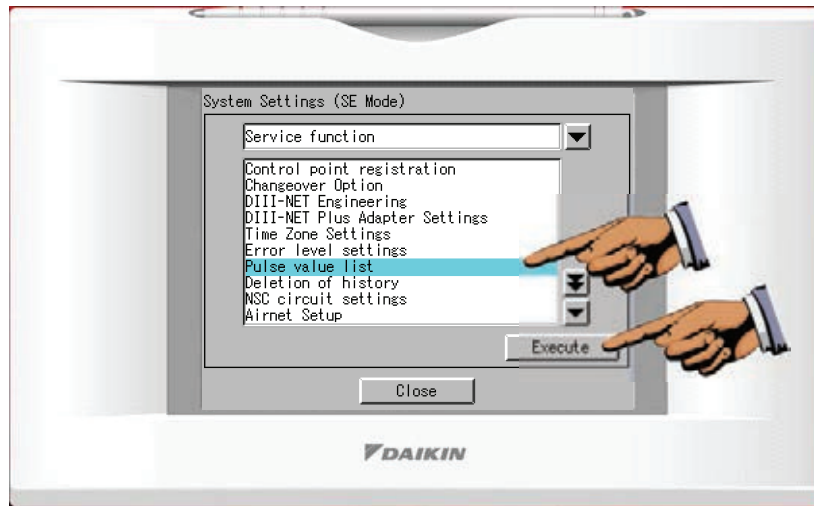

## Pulse Value List

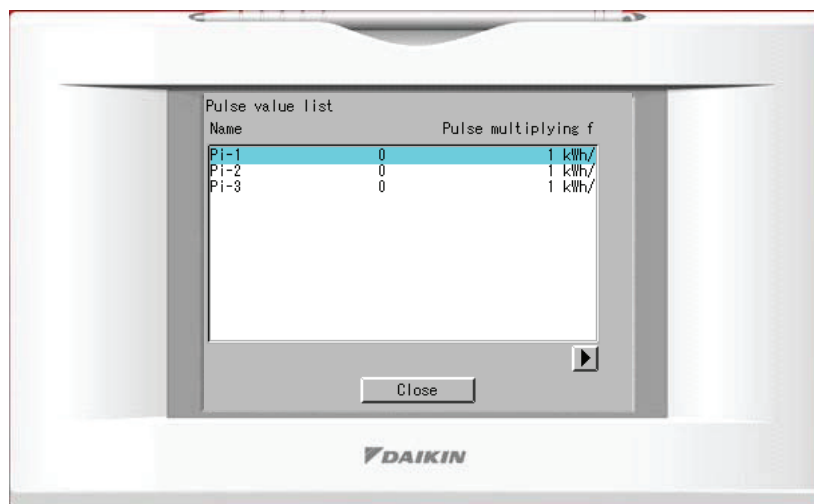

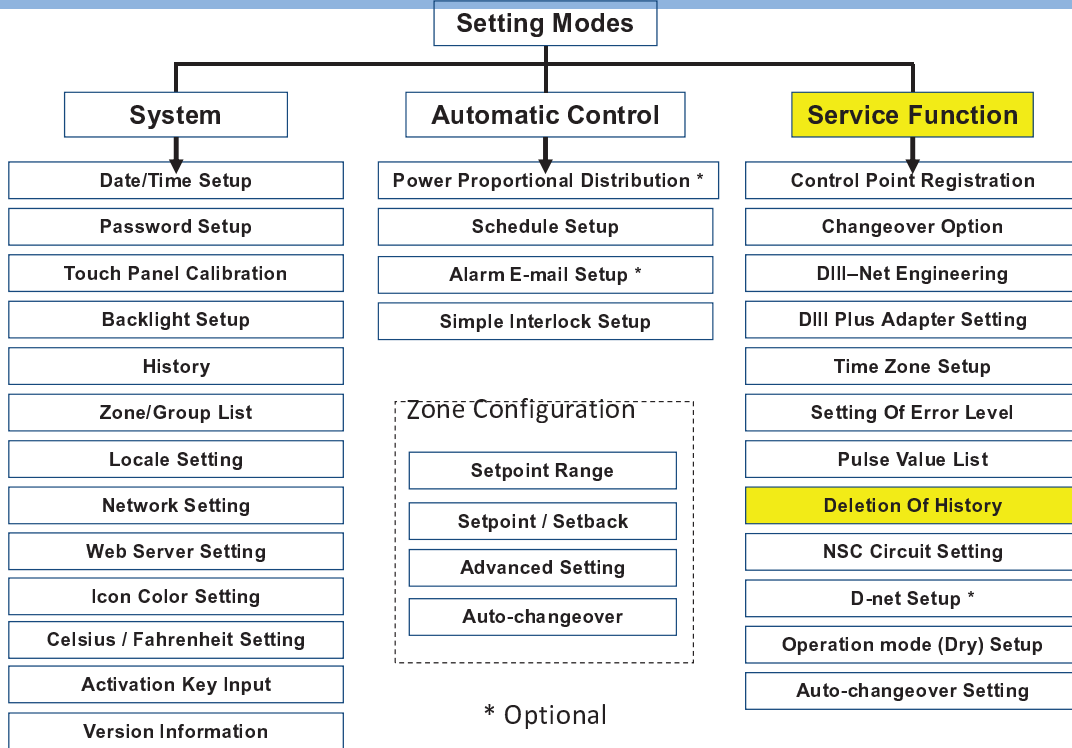

## Deletion Of History

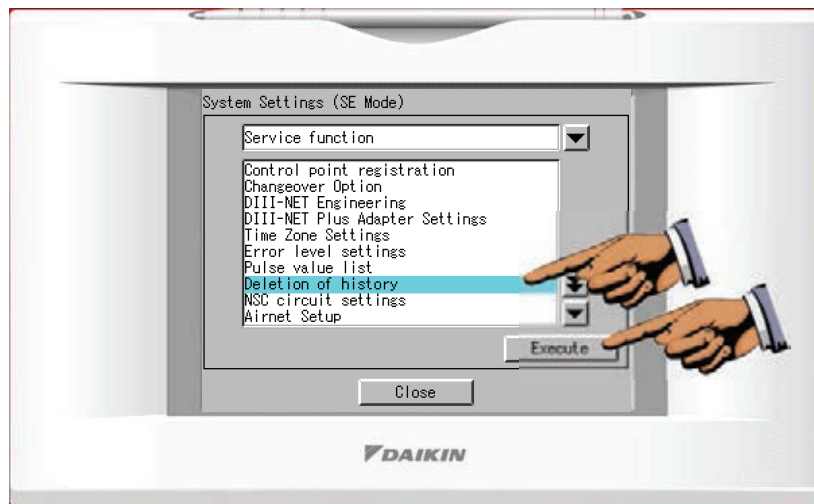

## Deletion Of History

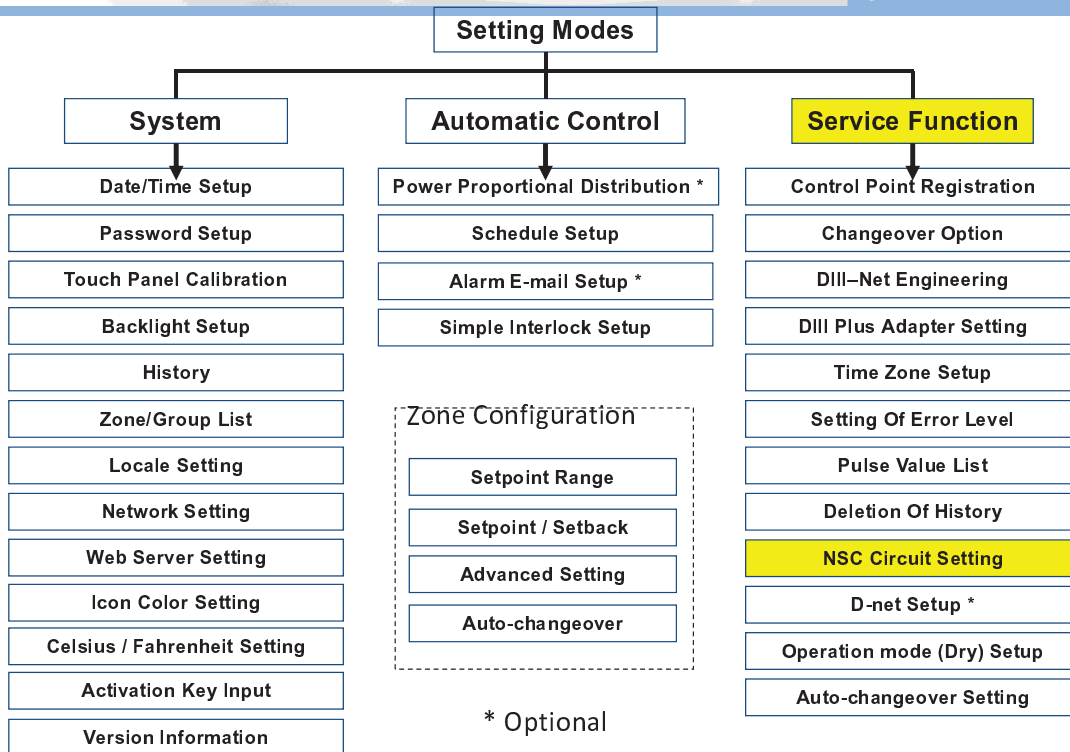
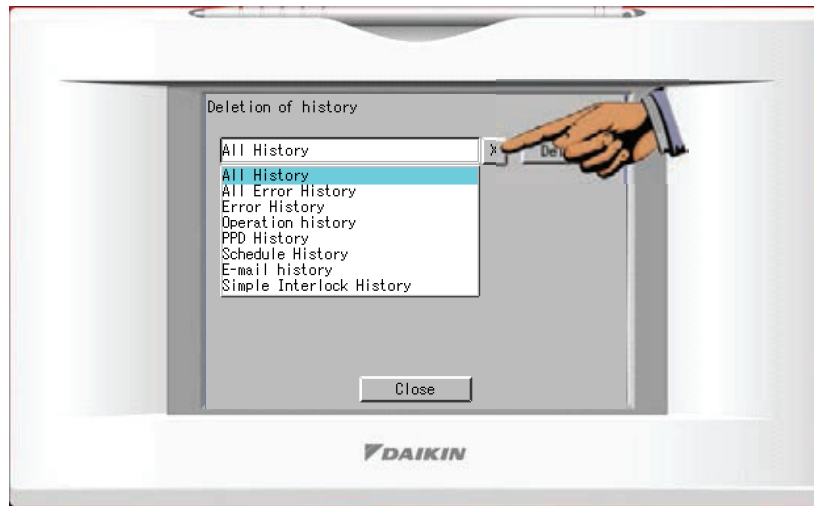



## NSC Circuit Setting

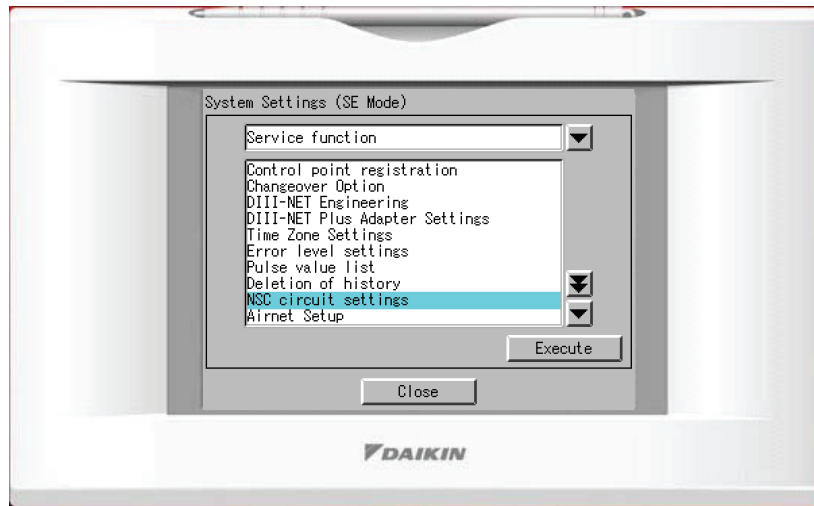

**DO NOT USE! - Use Ethernet connection for D-Net, see Network setting in System menu**

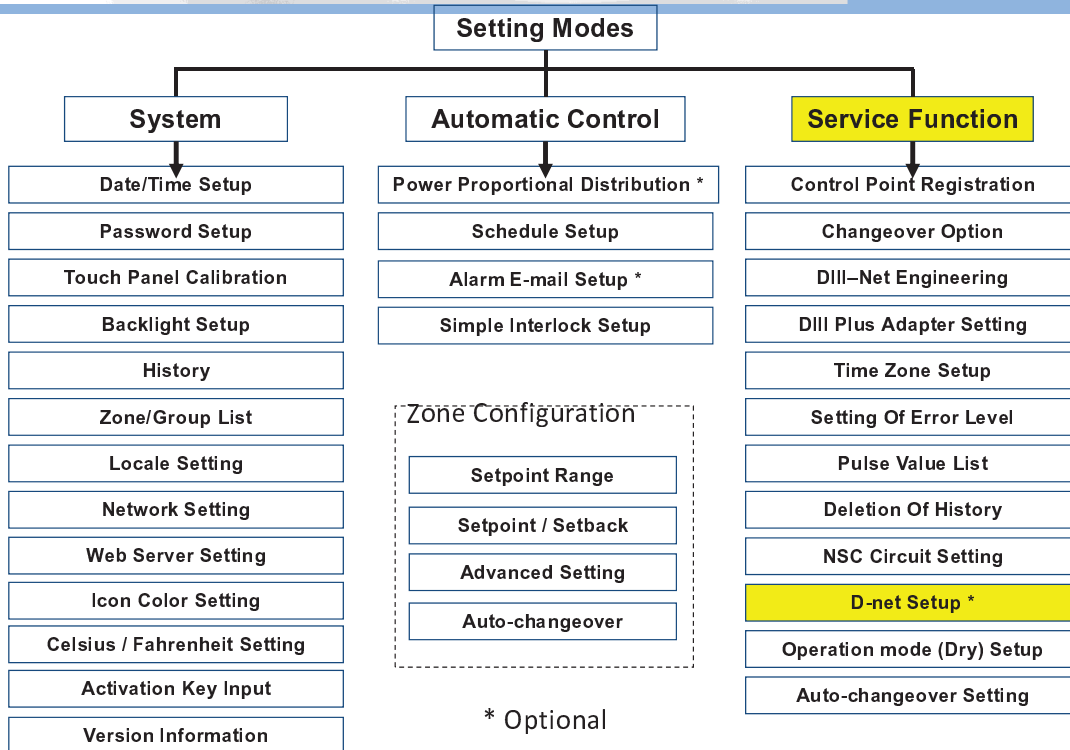

## D-net Setup

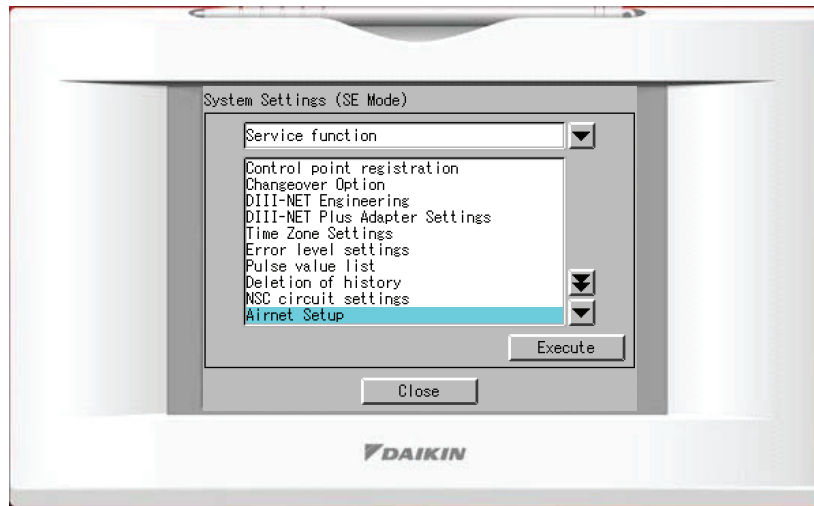

**Ask DACA Technical Service Dept**

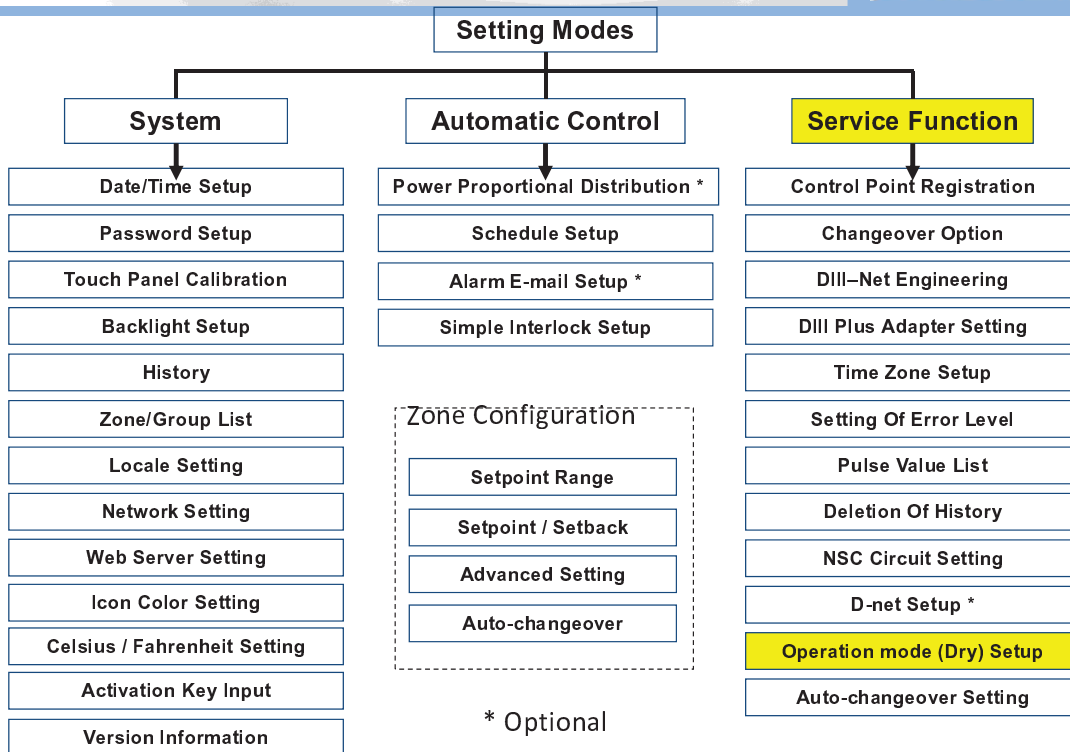

## Operation mode (Dry) Setup

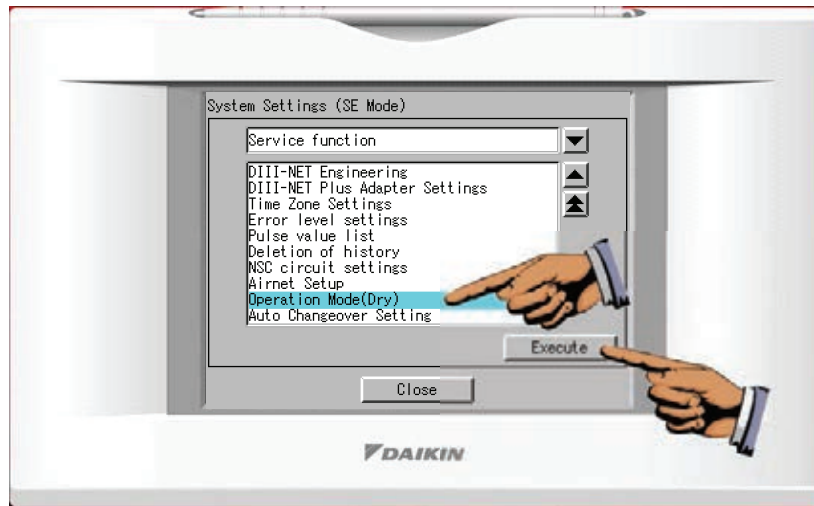

## Operation mode (Dry) Setup



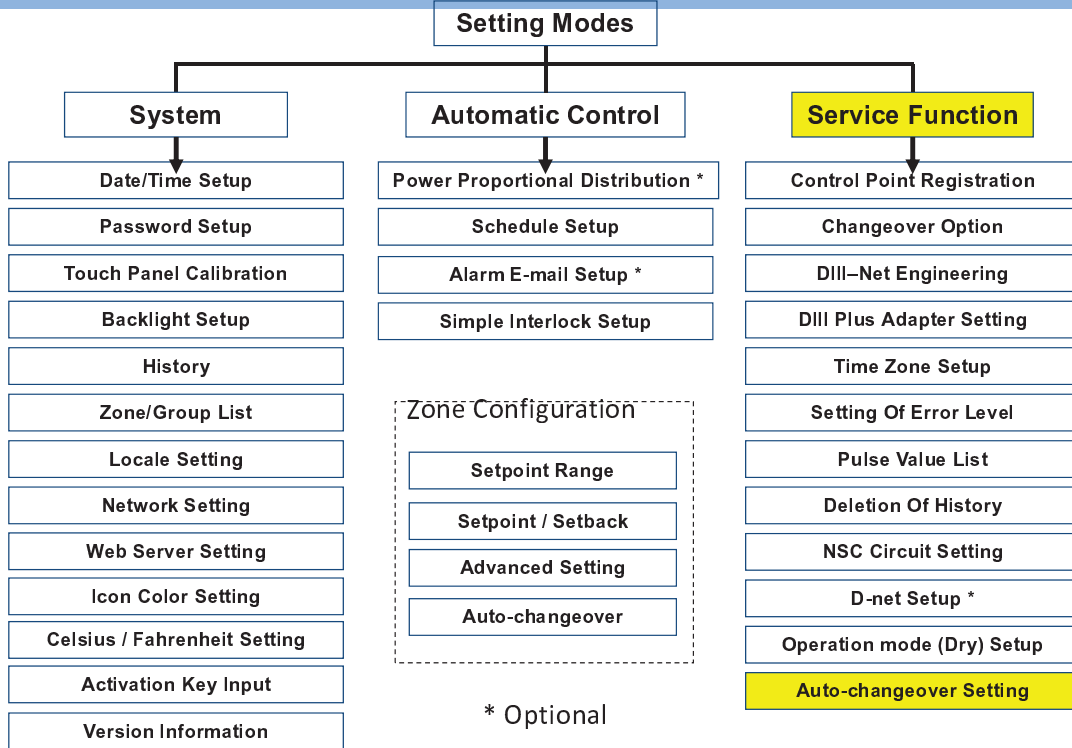

## Auto-changeover Setting

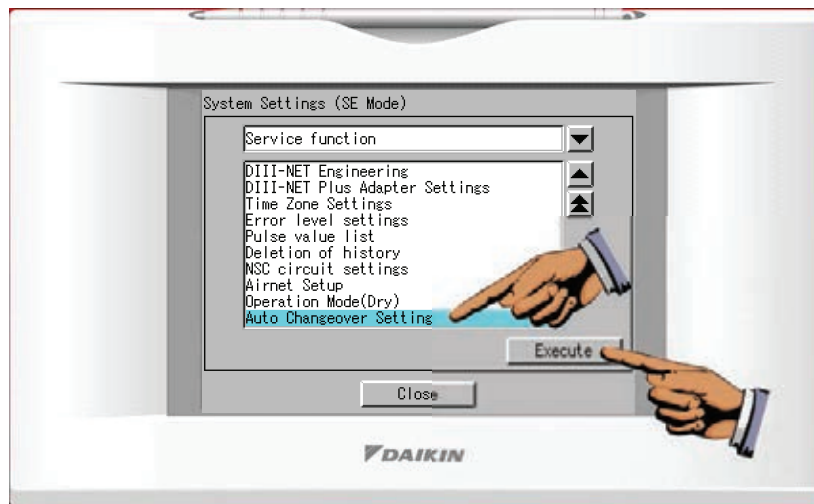

## Auto-changeover Setting

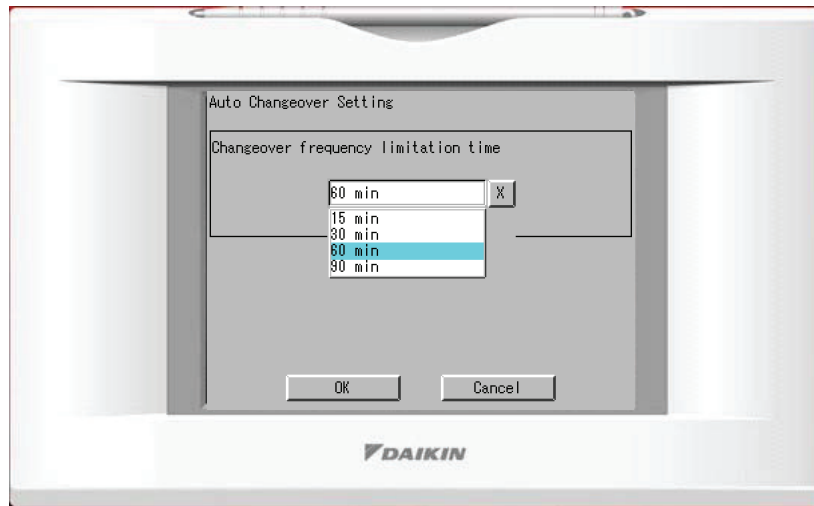

## Preset Tool – System Configuration, Backup, and Restore

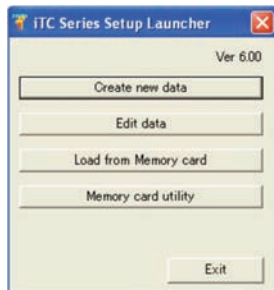

- Create New Data – For pre-engineering a job before visiting the jobsite.
  - Edit data – To edit pre-engineered configuration data which has already been created.
  - Memory Card Utility – To create files used to make system backups and restores.
- \* See Preset Tool Operation Manual for Instructions

\*Always make a backup of the latest system configuration before leaving the jobsite!



COMFORT FOR LIFE

*Thank You*



COMFORT FOR LIFE

**BACnet Interface - DMS502B71**

**Setup and Commissioning**



# BACnet Interface



## Combination Allowances



	Central Controller	Unified On/Off	Schedule Timer	iTouch Controller	iTouch Manager	BACnet Interface	LON Interface
Central Controller		OK	OK	OK	OK	OK	OK
Unified On/Off	OK		OK	OK	OK	OK	OK
Schedule Timer	OK	OK		NO	NO	NO	NO
iTouch Controller	OK	OK	NO		NO	OK	OK
iTouch Manager	OK	OK	NO	NO		OK	OK
BACnet Interface	OK	OK	NO	OK	OK		NO
LON Interface	OK	OK	NO	OK	OK	NO	



## Daikin's BACnet Interface – A Protocol Translator

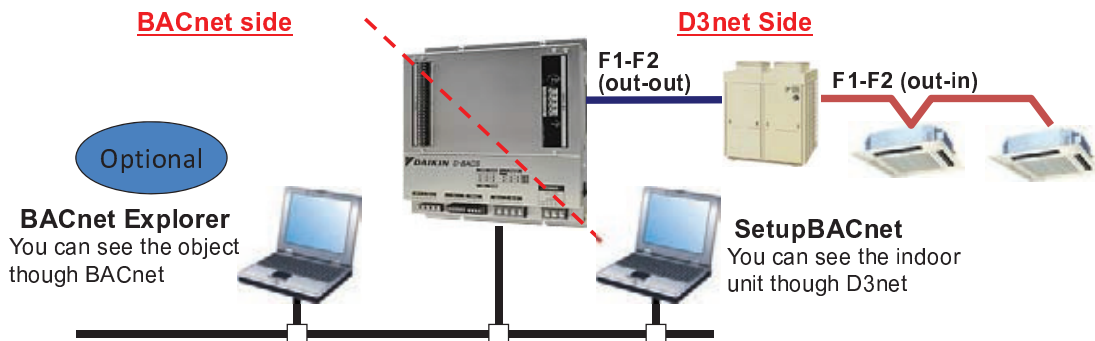



# BACnet / VRV Architecture

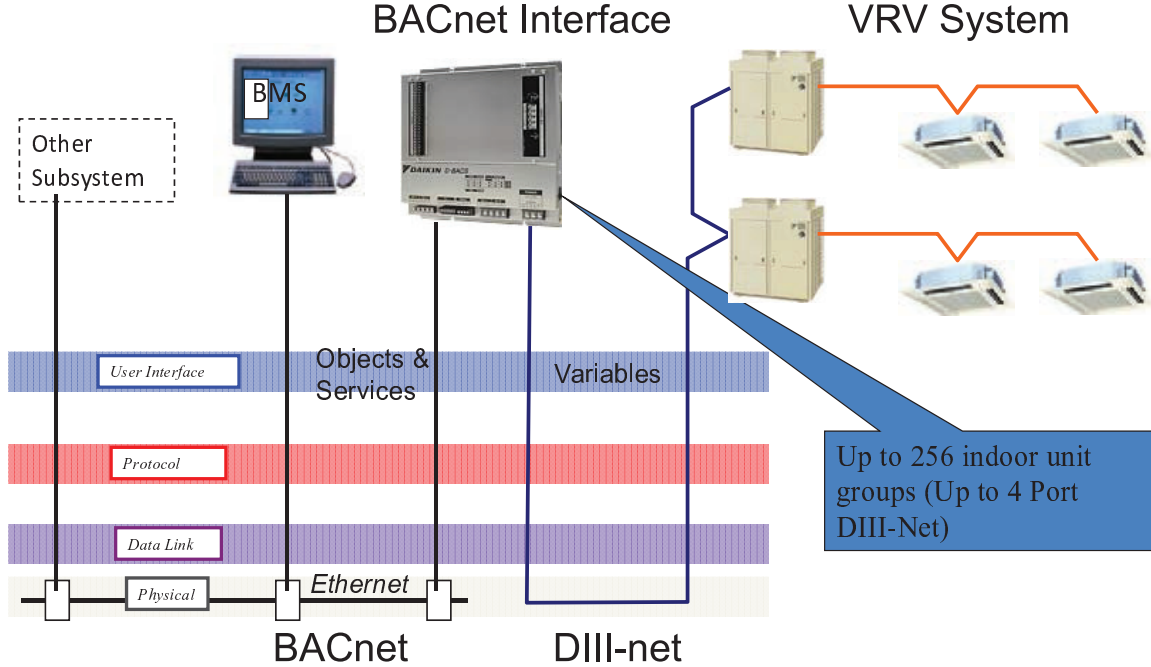

# BACnet Protocol Overview

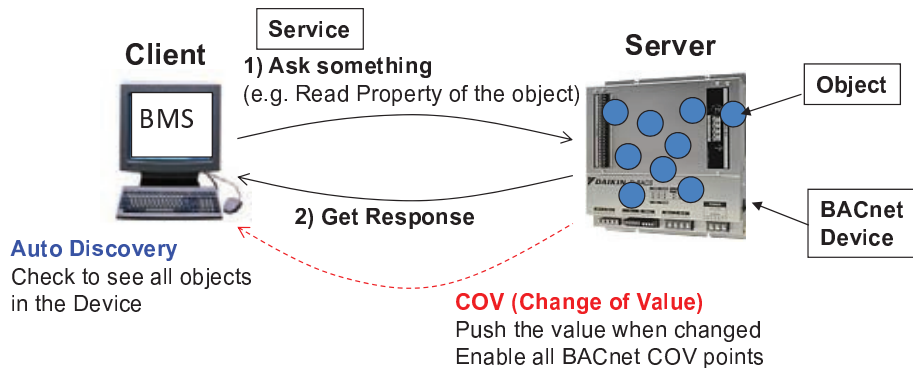

## Supporting BACnet Integration Tasks

	iTouch Controller iTouch Manager	LON Interface	BACnet Interface
<b>Establish Point List</b> (each project)		Nothing (Just send XIF file)	(Create Point List) * Auto Discovery feature becoming commonplace instead of the point list
<b>Unit Addressing</b>	Same as right	Same as right	Assign group address to indoor units
<b>Setup and Configuration</b> (each project)	Set up (Partial List) <ul style="list-style-type: none"> <li>• Group Name Assignments</li> <li>• Zone Configuration</li> <li>• Limits Setting</li> <li>• Schedule Programming</li> </ul>	Set up <ul style="list-style-type: none"> <li>• Enable Battery Backup</li> </ul>	Set up (setupBACnet tool) <ul style="list-style-type: none"> <li>Instance Number</li> <li>IP Addressing / Network Settings</li> <li>Time and Date Setting / Time Zone</li> </ul>
<b>Commissioning</b> (each project)	Check Daikin System (iTC + VRV system)	Check Daikin System (LON GW + VRV system) <ul style="list-style-type: none"> <li>• Daikin DIII net configuration only</li> </ul>	Check Daikin System (BACnet Interface + VRV system) Daikin DIII-Net configuration only

## BACnet Interface External Appearance

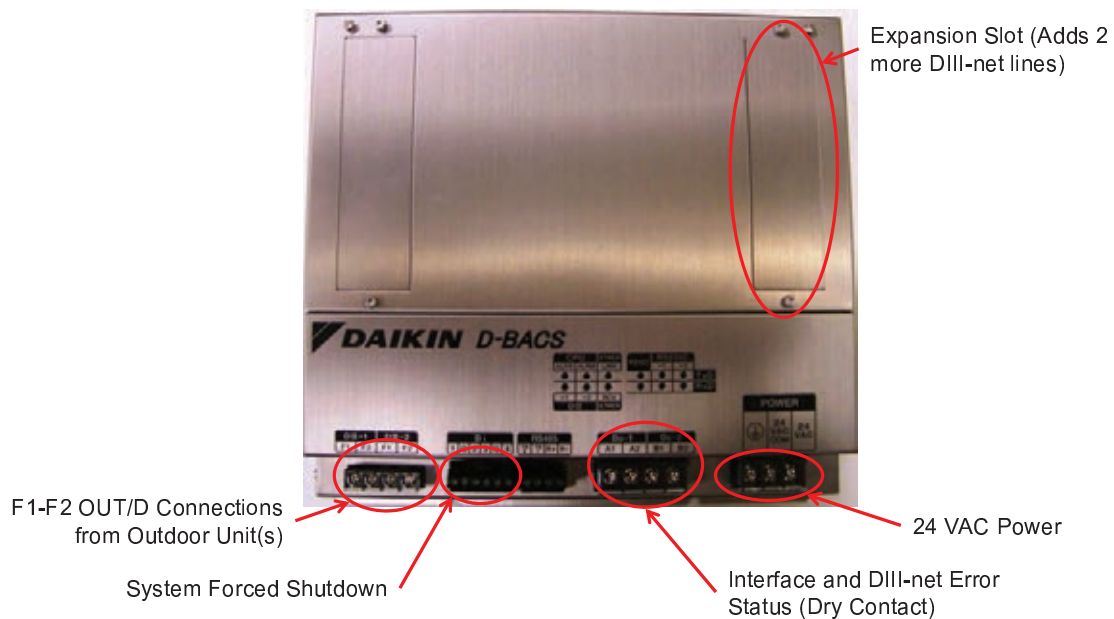

# BACnet Interface External Appearance

Serial Connection  
(Necessary when  
Ethernet IP address  
is unknown)



Left Side

Ethernet Port

Power Switch



Right Side

Backup Battery Switch  
(Communications ports will  
not operate when this  
switch is off and an error  
will generate).

## Set Group Addressing – BRC1E71/72



- When a multi zone controller is connected, group address setting is available in Service Settings

- Push any key to activate backlight
- Hold Cancel button for 4 seconds to enter Service Settings Menu

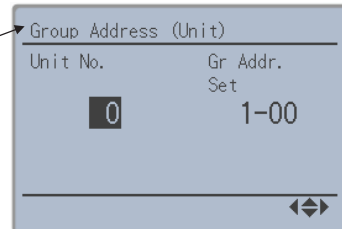
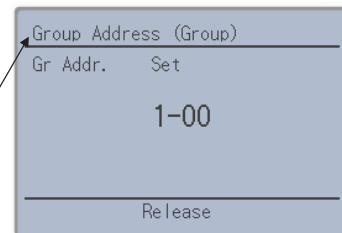
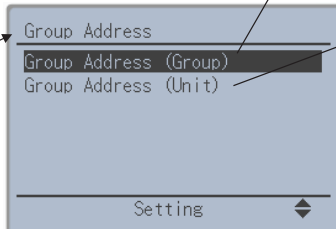
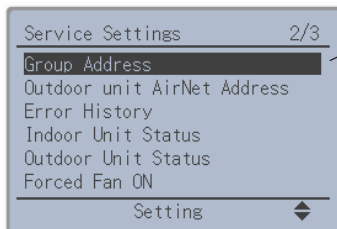

# Group Addressing – BRC2A71

Open the cover of the controller and you can see the setting switches of BS 6 to 10



- **Simplified remote controller**
- Group No. setting by simplified remote controller.
  1. Remove the cover of remote controller.
  2. While in normal mode, press the [BS6] BUTTON (field set) to enter the FIELD SET MODE.
  3. Select the mode No. [00] with [BS2] BUTTON (temperature setting ▲) and [BS3] BUTTON (temperature setting ▼).
  4. Select the group No. with [BS9] BUTTON (set A) and [BS10] BUTTON (set B). (Group Nos. increase in the order of 1-00, 1-01.....1-15, 2-00,.....4-15. However, the unified ON/OFF controller displays only group No. set within the range of control.)
  5. Press [BS7] BUTTON (set/cancel) to set group No.
  6. Press [BS6] BUTTON (field set) to return to the NORMAL MODE.

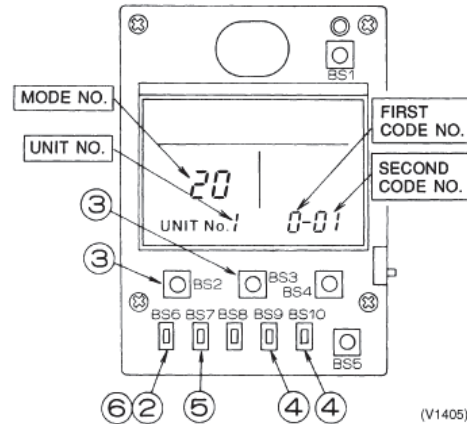

(V1405)

# Group Addressing – BRC1D71

When applying a Daikin “Multi-zone Controller” such as an BACnet, i-Touch Controller, i-Manager or Centralized Controller to the VRV system, indoor unit group addressing must be done manually. This establishes each groups identity. This programming is accomplished utilizing the Daikin remote controller.

1. Press and hold the TEST **1** button for 5 seconds to enter the programming mode.
2. Display should indicate mode 00 with the current group assignment as 1-01. Available address are 1-00 to 1-15, 2-00 to 2-15 3-00 to 3-15, 4-00 to 4-15.
3. The word “GROUP” should be flashing. If not, press the SCHEDULE **2** button.
4. Using the TIME **3** buttons, set the desired address.
5. Once the desired address has been set, press the SCHEDULE **2** button to confirm the new address.
6. Press the TEST **1** button to exit programming mode.



## Local Area Network

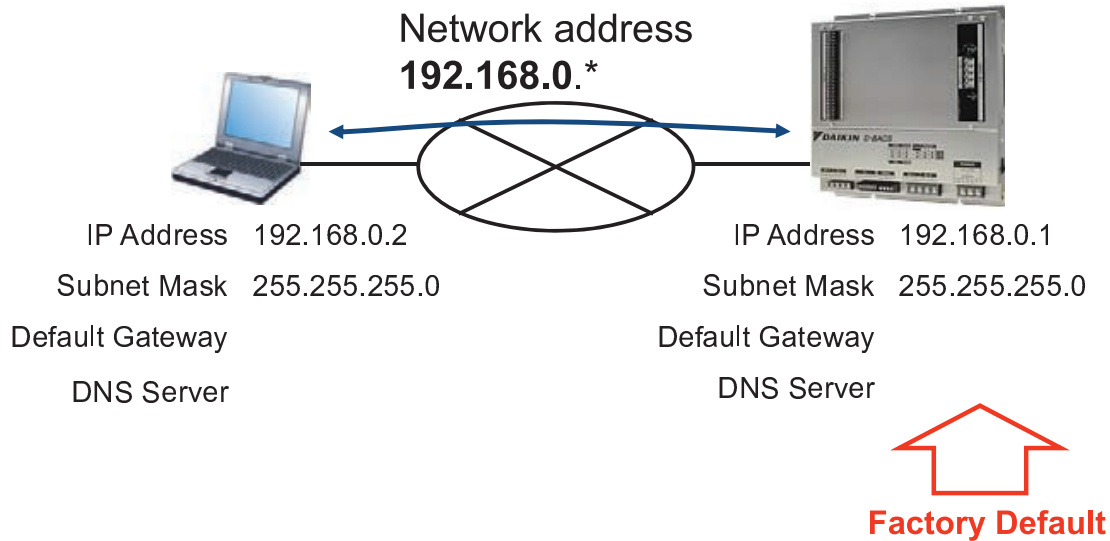

## BACnet Configuration

### Before you Connect your Laptop

- ✓ Instance Number
- ✓ New Static IP Address of BACnet Interface
- ✓ New Subnet Mask Number of BACnet Interface
- ✓ New Default Gateway Address of BACnet Interface
- ✓ IP Address of BBMD if Gateway is on different Subnet

# BACnet Configuration

**Option 1 : Laptop using “Cross Over” cable to Ethernet port**

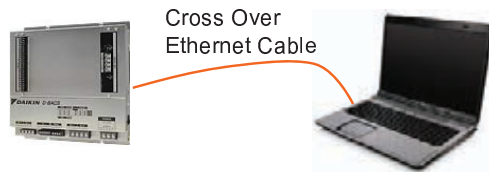

**Option 2 : Laptop using two straight cables and a hub or switch to Ethernet port**

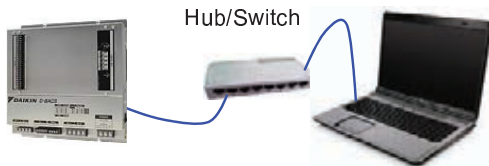

**Option 3 : Laptop using “Cross Over” serial cable to RS232C-1 port**

(DLS-CABLE-9PIN)

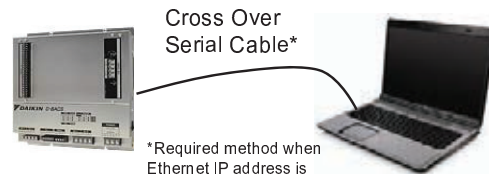

\*Required method when Ethernet IP address is unknown.

# BACnet Configuration

## Computer Set Up

After connecting the laptop to the BACnet Interface, open up the “Local Area Connection” by going to Start -> Settings -> Network Connections -> Local Area Connection.

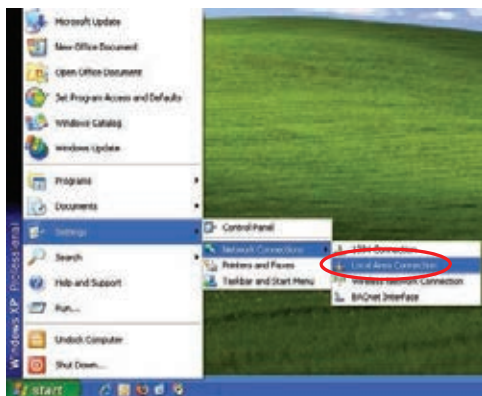

When the “Local Area Connection Status” popup displays, click on the “Properties”.

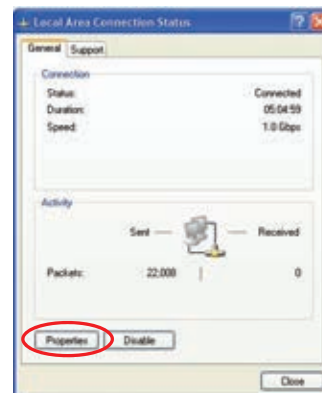

# BACnet Configuration

## Computer Set Up

When the "Local Area Connection Properties" windows pops up, scroll down to "Internet Protocol (TCP/IP)" and highlight, and click "Properties".

Click on "Use the following IP address:" and enter 192.168.0.2 for the IP address and 255.255.255.0 for the Subnet mask if it does not fill in automatically, then click "OK".

Click "OK". After a brief period, you should be connected.

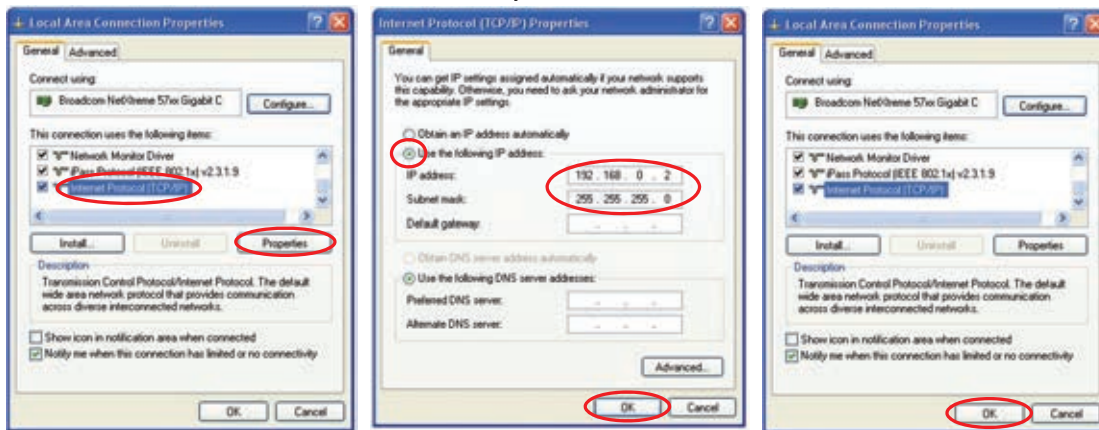

# BACnet Configuration

## Sourcing and Installing the setupBACnet Configuration Software

- Consult Daikin AC Tech Support for BACnet setup software.
- Commission checklist will be required.

E-mail: [techsupport@daikinac.com](mailto:techsupport@daikinac.com)



SetupToolForBACnetGatewayVer6.201

**DAIKIN AC** (American) Inc.  
1545 Wilshire Blvd, Suite 115  
Culver City, CA 90230 USA  
TEL: 888-DAIKIN FAX: 310-206-1038  
www.daikinac.com

**Controls Pre-Commissioning Checklist**  
BACnet, Lowvoltage

Purchase Order Number: \_\_\_\_\_ Contractor: \_\_\_\_\_

**1 - TO DO CRITICAL**

MAC Address: \_\_\_\_\_ Software ID: \_\_\_\_\_

Single Location or not: \_\_\_\_\_ Power to Front End: Yes  No

Number of Floors: \_\_\_\_\_ Floor Size (sq ft): \_\_\_\_\_ Number of Buildings: \_\_\_\_\_

Building Type: \_\_\_\_\_ Number of HVAC Units: \_\_\_\_\_

Main System (select one): \_\_\_\_\_ Number of VAV Units: \_\_\_\_\_

Number of Chilled Water: \_\_\_\_\_ Number of Cooling Coils: \_\_\_\_\_

# Other Building (Name, Type, School, etc.): \_\_\_\_\_

**WEB OPTION**

Web Software ID: \_\_\_\_\_ Remote Stack Address: \_\_\_\_\_

IP Address (select one): \_\_\_\_\_ Primary DNS Address: \_\_\_\_\_

Secondary DNS Address: \_\_\_\_\_

Activation Code: \_\_\_\_\_

PPD Option: Yes  No

PPD Software: \_\_\_\_\_ MAC Address: \_\_\_\_\_

Brand of KW Meters: \_\_\_\_\_ Model of KW Meter: \_\_\_\_\_

Number of KW Meters: \_\_\_\_\_ Activation Code: \_\_\_\_\_

**BACNET: Yes  No**

MANUFACTURER OF FRONT END SYSTEM: \_\_\_\_\_

IP Address: \_\_\_\_\_

Default Gateway Address: \_\_\_\_\_

Instance Number: \_\_\_\_\_

Subnet Mask: \_\_\_\_\_

Power to BACnet: Yes  No

**LOWVOLTAGE: Yes  No**

MANUFACTURER OF FRONT END SYSTEM: \_\_\_\_\_

Power to Lowvoltage: Yes  No

I hereby certify that all items on this list have been checked, and that all information is correct.  
I further verify that the job is ready for commissioning. I realize that if upon arrival to the commissioning the job is not ready for start up, that I will be subject to additional fees as described in the Daikin Policies and Procedures Guide.

Contractor Signature: \_\_\_\_\_  
Date: \_\_\_\_\_

Control - 1 - Ver. ELEC

# BACnet Configuration

## BACnet Interface Set Up

Locate the folder that has your BACnet GW Service Tool software.

Once you open this folder double click on the icon "SetupBACnet.exe".

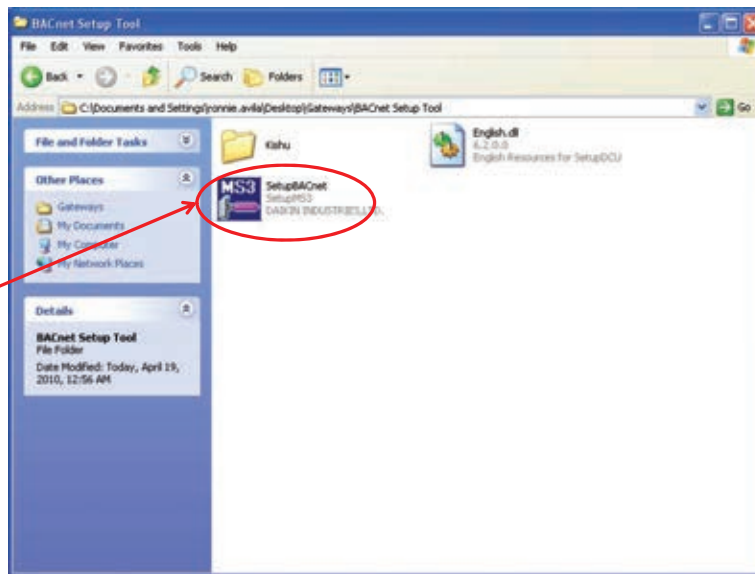

# BACnet Configuration

## BACnet Interface Set Up

Change the IP Address to:  
192.168.0.1 (Factory Default)  
Then click "OK"

**NOTE:** When connecting to the BACnet Interface via the RS232C, use IP address 192.168.3.1.

A null modem must be configured in the PC to utilize the serial connection.

This is useful if the primary device IP address and / or subnet mask is unknown.

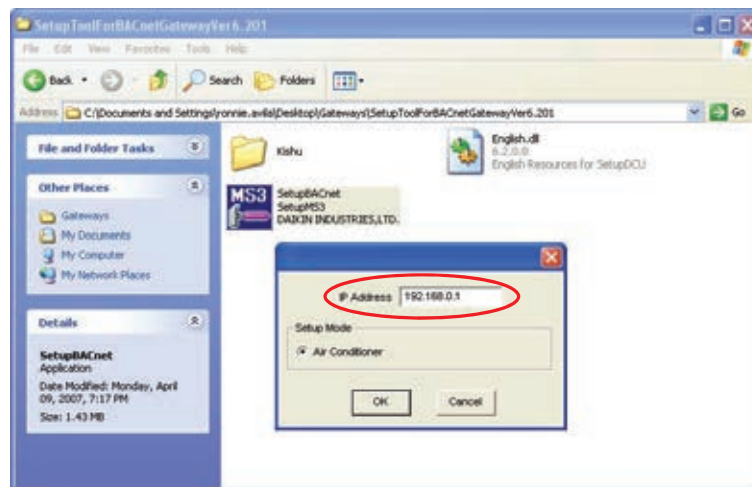



# BACnet Configuration

## BACnet Interface Set Up

If this window appears something was connected or entered wrong. Click "OK" and check you connections and then your IP address inputs, then try again.

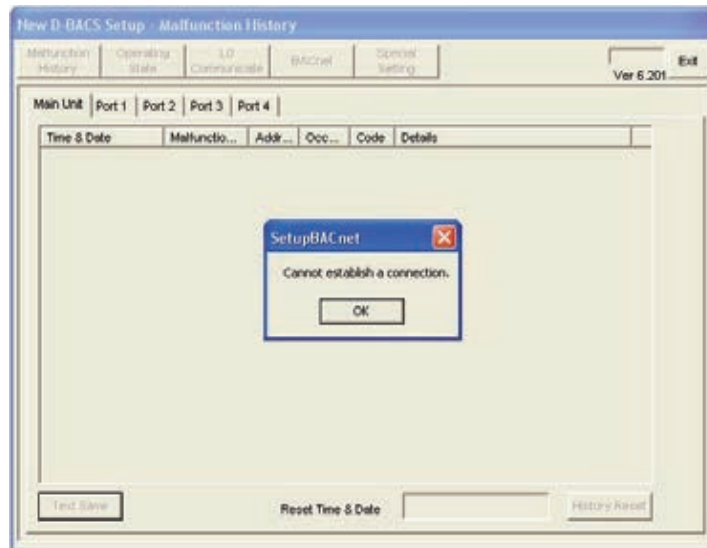

# BACnet Configuration

## BACnet Interface Set Up

This window appears if you are connected properly.

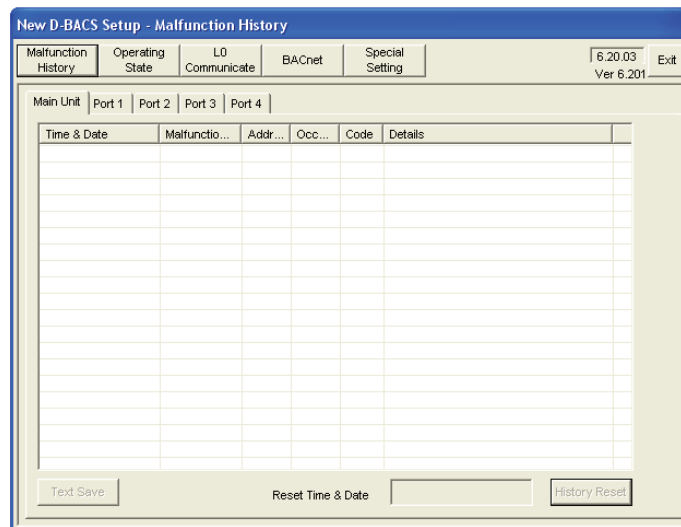

# BACnet Configuration

## BACnet Interface Set Up

### Operating State

Click on "Operating State"

You should see all your indoor unit groups listed.

Click on "Aircon Control"

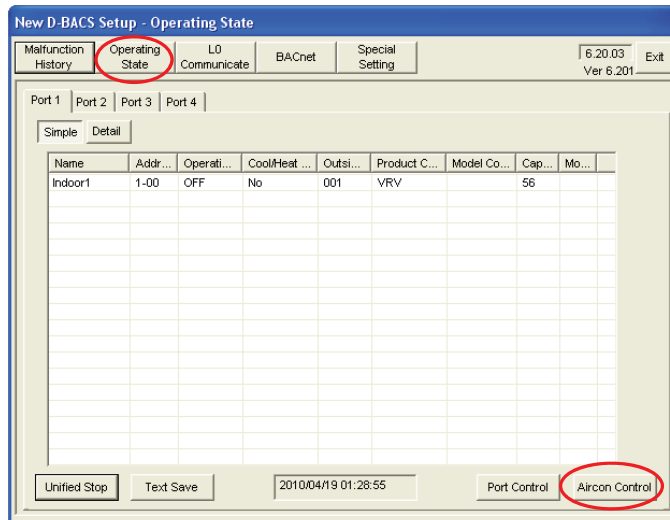

# BACnet Configuration

## BACnet Interface Set Up

### Aircon Control

Start and stop each indoor unit individually to ensure that the group addresses relate to the proper equipment designations within the building automation system.

**NOTE:** Communication through the Setup Tool is NOT BACnet and does not ensure communication through the BMS.

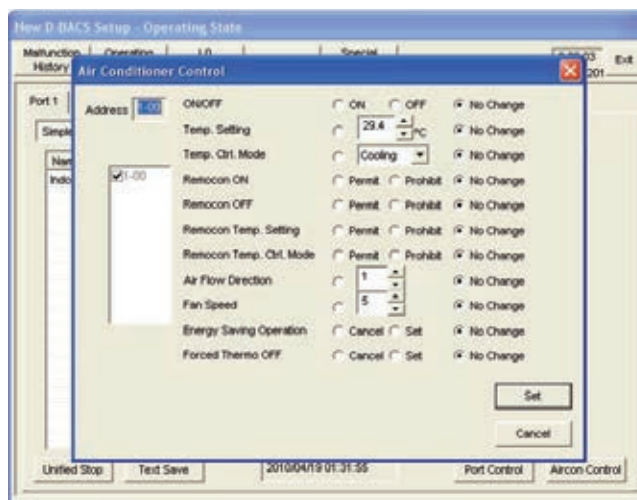

# BACnet Configuration

## BACnet Interface Set Up

### Instance Number

Select the "Instance" tab.

Changes will not take effect until the BACnet Interface's power is cycled off and back on.

Instance Number should be within 0 to 4,194,303 (3FFFFFF<sub>Hex</sub>)

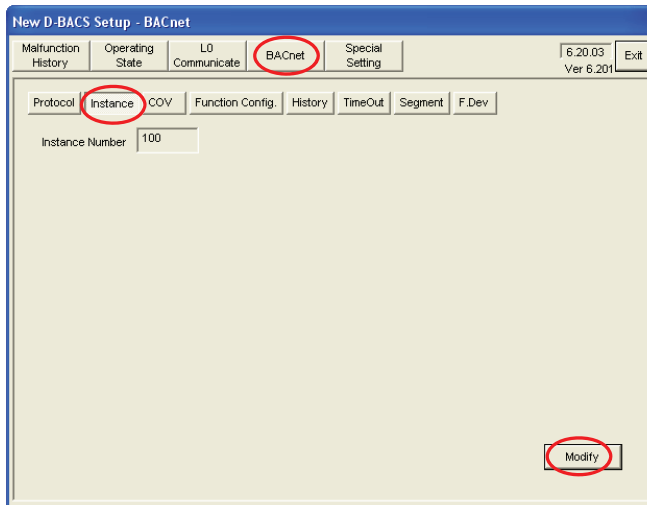

# BACnet Configuration

## BACnet Interface Set Up

### Change of Value (COV)

Select the "COV" tab.

Click the "Modify" button to enable COV for each point

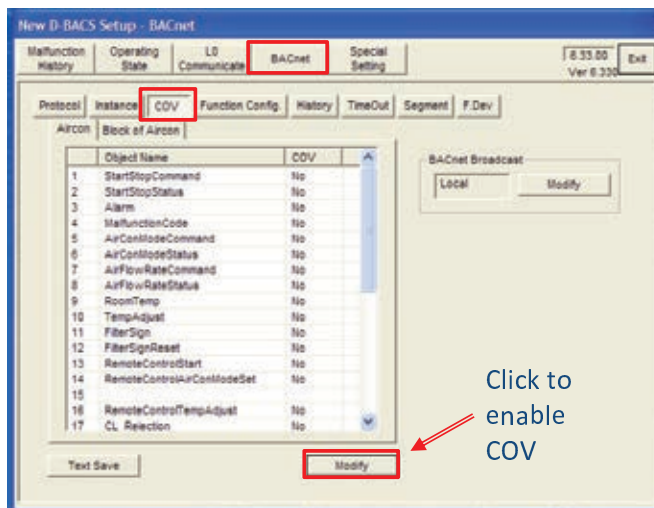

# BACnet Configuration

## Change of Value (COV)

- Click the check box for each point to enable the COV
- Click "Set" to save changes after all COVs have been enabled

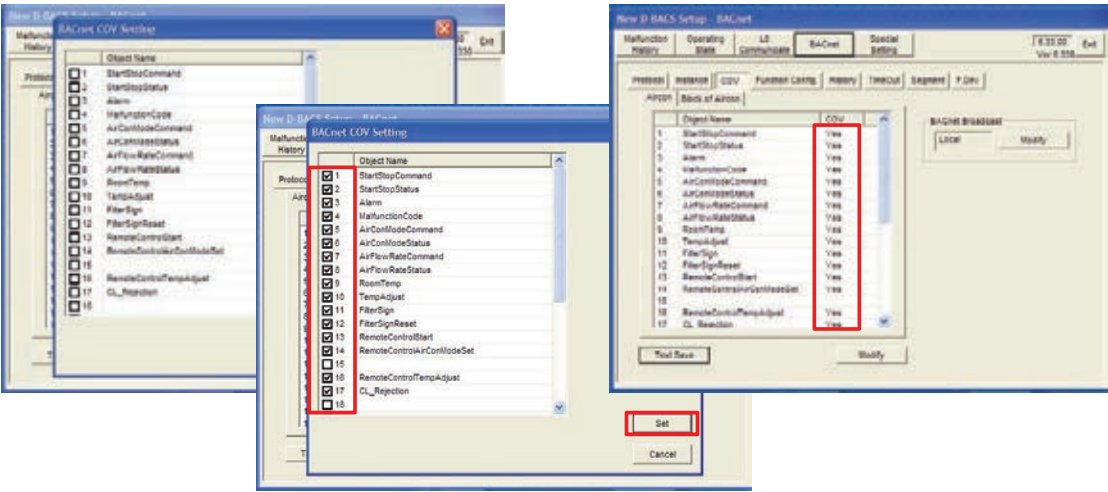

# BACnet Configuration

## BACnet Interface Set Up

### Foreign Device

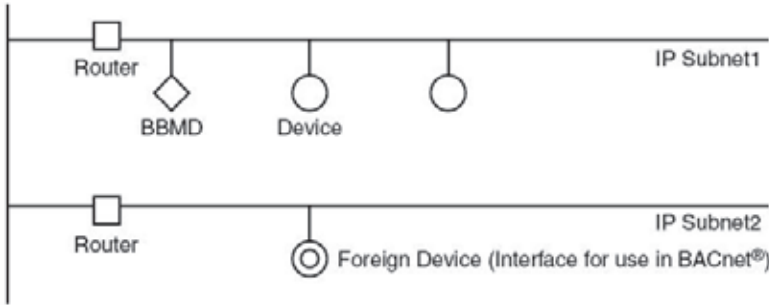

# BACnet Configuration

## BACnet Interface Set Up

### Foreign Device

Select the "F.Dev" tab.

Changes will not take effect until the BACnet Interface's power is cycled off and back on.

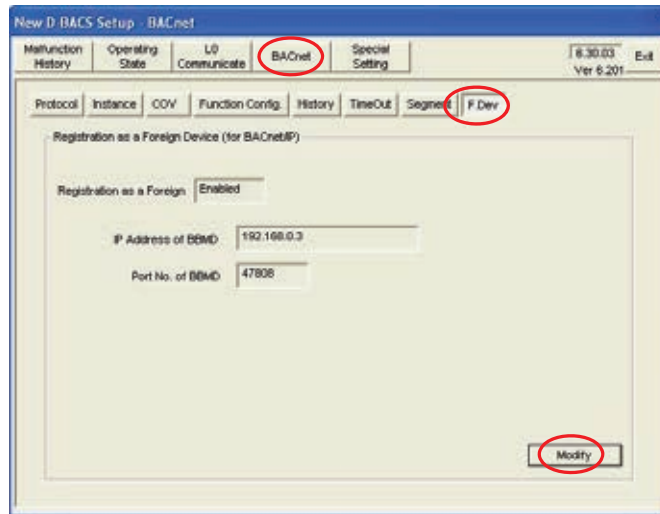

# BACnet Configuration

## BACnet Interface Set Up

### Foreign Device

(a) Register to BBMD as a Foreign Device (at startup of Master Station, and thereafter at a regular interval)

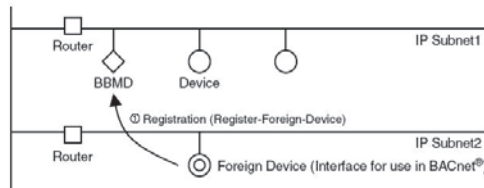

(b) Broadcast messages forwarded via BBMD

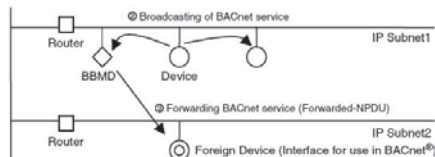

(c) Send its own broadcast messages to other devices on other subnets via BBMD

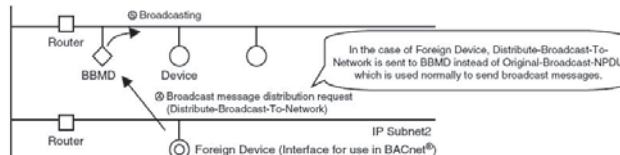

# BACnet Configuration

## Special Settings Set Time Zone

**Note: Be sure your PC is configured for the same time zone where the Interface exists**

# BACnet Configuration

## Special Settings - Setting IP Address

IP Address, Subnet Mask, and Default Gateway Address will come from the Network Administrator.

# BACnet Configuration

## Special Settings

### Setting Clock

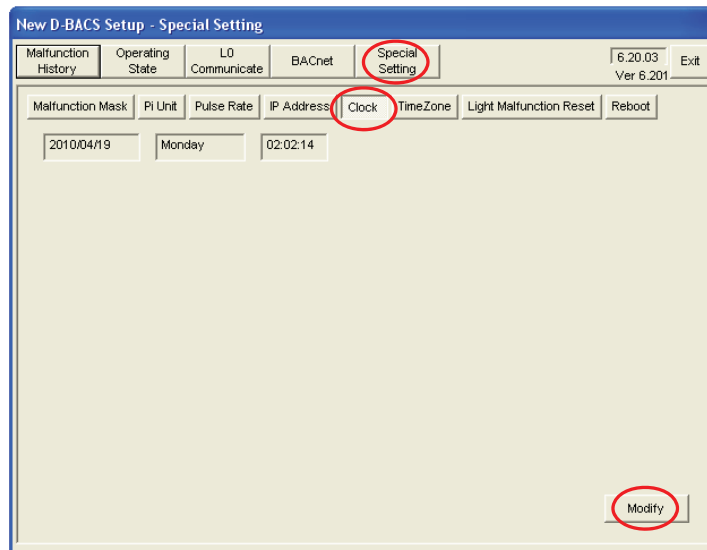

**Note: Be sure your PC is configured for the same time zone where the Interface exists**

# BACnet Configuration

## BACnet Interface

Now it is time to **cycle power** to the BACnet Interface.

After power is cycled you can plug in the Ethernet cable from the building automation system network.

Have the building automation system administrator scan for the newly assigned Instance number.

You should provide this person with a copy of the BACnet Design Guide and a copy of the BACnet GW Service Tool Software. (setupBACnet)



Left Side



Right Side

## BACnet Interface – BACnet Explorer Verification

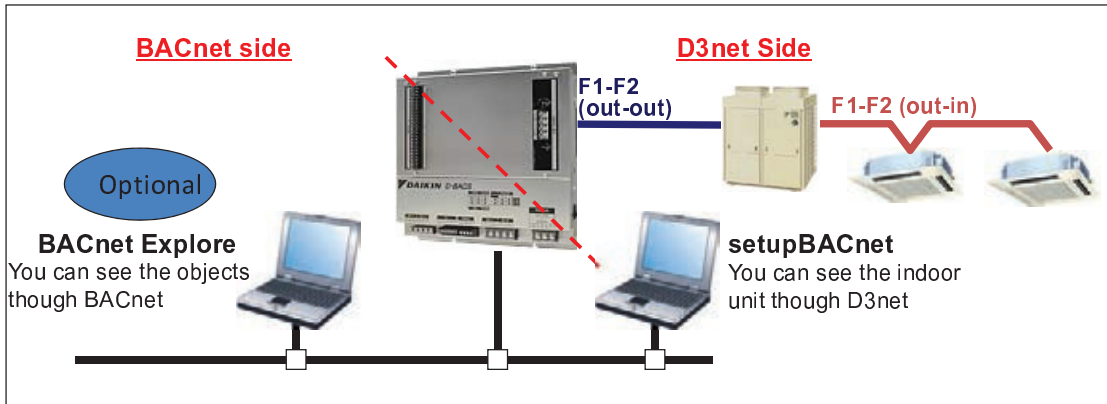

B5001 - BACnet Explorer XML

- Automatic discovery of BACnet devices, objects and properties
- Expanding Tree display
- Read / Write property values
- Save point lists in machine readable format using XML
- BACnetEthernet, BACnet/IP, BACnet MS/TP

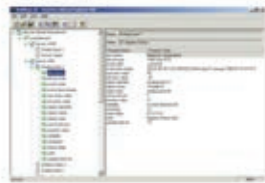

<http://www.cimetrics.com>



COMFORT FOR LIFE

*Thank You*





COMFORT FOR LIFE

## **LonWorks Gateway – DMS504C71**

**Installation  
Commissioning  
Programming**



# iTouch Controller



## Combination Allowances



	Central Controller	Unified On/Off	Schedule Timer	iTouch Controller	iTouch Manager	BACnet Interface	LON Interface
Central Controller		OK	OK	OK	OK	OK	OK
Unified On/Off	OK		OK	OK	OK	OK	OK
Schedule Timer	OK	OK		NO	NO	NO	NO
iTouch Controller	OK	OK	NO		NO	OK	OK
iTouch Manager	OK	OK	NO	NO		OK	OK
BACnet Interface	OK	OK	NO	OK	OK		NO
LON Interface	OK	OK	NO	OK	OK	NO	



## LonWorks Defined

LonWorks is a networking platform specifically created to address the unique performance, reliability, installation, and maintenance needs of control applications. The platform is built on a protocol created by [Echelon Corporation](#) for networking devices over media such as [twisted pair](#), [powerlines](#), [fiber optics](#), and [RF](#). It is popular for the automation of various functions within buildings such as [lighting](#) and [HVAC](#); see [Intelligent building](#).

The platform has its origins with chip designs, power line and twisted pair signaling technology, routers, network management software, and other products from [Echelon Corporation](#). In 1999 the communications protocol (then known as [LonTalk](#)) was submitted to [ANSI](#) and accepted as a standard for control networking (ANSI/CEA-709.1-B). Echelon's power line and twisted pair signaling technology was also submitted to ANSI for standardization and accepted. Since then, ANSI/CEA-709.1 has been accepted as the basis for IEEE 1473-L (in-train controls), [AAR](#) Electro-pneumatic braking systems for freight trains, IFSF (European petrol station control), [SEMI](#) (semiconductor equipment manufacturing), and in 2005 as EN 14908 (European building automation standard). The protocol is also one of data link/physical layers of the [BACnet ASHRAE/ANSI](#) standard for building automation.

# Simple LonWorks Network

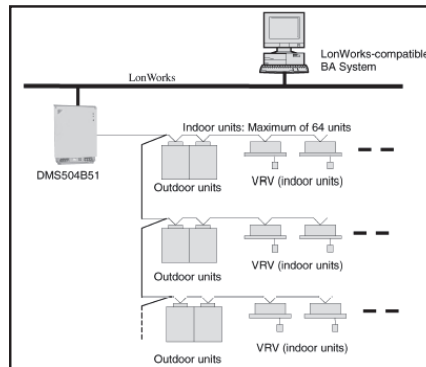
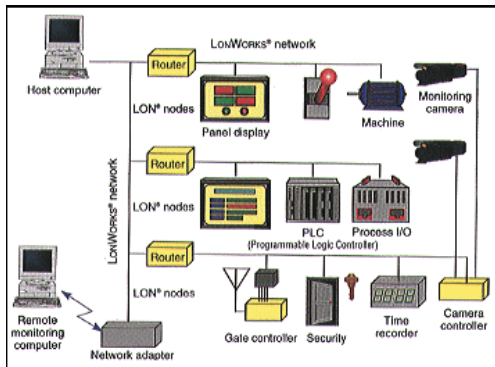

## The LonWorks Protocol

Devices in a LonWorks network communicate through the LonWorks protocol. This provides a set of services that lets a device's application program send and receive messages to and from other network devices—without needing to know the network topology or the other devices' names, addresses, or functions. The LonWorks protocol can optionally provide end-to-end acknowledgement of messages, authentication of messages, and priority delivery to provide bounded transaction times. Support for network management services lets remote network management tools interact with devices over the network, so they can: reconfigure network addresses and parameters download application programs report network problems start/stop/reset device application programs The LonWorks protocol, and thus LonWorks networks, can be implemented over basically any medium, including [power line](#), twisted pair, radio frequency (RF), infrared (IR), coaxial cable and fiber optics.

# The LonWorks Platform

- **Communications protocol** This protocol is the underlying technology of a LonWorks control network. An international standard, it's known as ANSI/EIA709.1, SEMI E56.6, IEEE 1493-L, EN14908, and others.
- **Dedicated microprocessor** Invented by Echelon, this processor (also known as the Neuron chip) is highly optimized for devices on a control network. Neuron chips have three 8-bit inline processors: two are dedicated to the communications protocol and one is a general-purpose applications processor. A number of chip manufacturers market the Neuron family of microprocessors.
- **Transceivers** These components transmit the protocol on a specific media, such as twisted-pair or power line. All devices on a control network must have a transceiver. Our twisted-pair and power line signaling technology have been approved as ANSI/EIA709.3 and 709.2, respectively. Both are also expected to be included in EN14908.
- **Network database** Called the LNS Network Operating System, this database is the required software component of open control systems; it ensures an open environment for extending, maintaining, and managing LonWorks based systems. The network operating system serves critical functions in a control network. LNS also supports a plug-in architecture.
- **Internet connectivity** The standardized applications (called LonMark profiles) and Standard Network Variable Types (SNVTs) of a LonWorks network pass through Internet connectivity devices via Web services (SOAP calls in XML format). Accessing and controlling LonWorks networks via Web services—an international IT standard—lets them become integral parts of enterprise applications, services centers, and more.
- **Interoperability** Interoperability means that devices created by different manufacturers can work together without needing a gateway to translate data from one device to another. A single, standardized software tool—LonMaker for Windows—manages and installs such disparate devices. Interoperability in the LonWorks world is governed by the LonMark International Group, which maintains interoperability guidelines, creates standard applications, and tests and certifies products.

# The LonWorks Platform

- Terms to Recognize:
  - LonWorks®: Network developed by Echelon®
  - LonTalk®: Standard protocol
  - LonMark® International
    - Independent standards organization to facilitate interoperability
    - Certifies products to functional profiles
    - Lon Gateway is not LonMark certified
  - Lon Gateway communicates over
    - Non-polarity sensitive, twisted pair wire
    - FTT-10A transceivers
  - eXternal Interface File (XIF) documents device information

## Daikin's LonWorks Gateway – A Protocol Translator

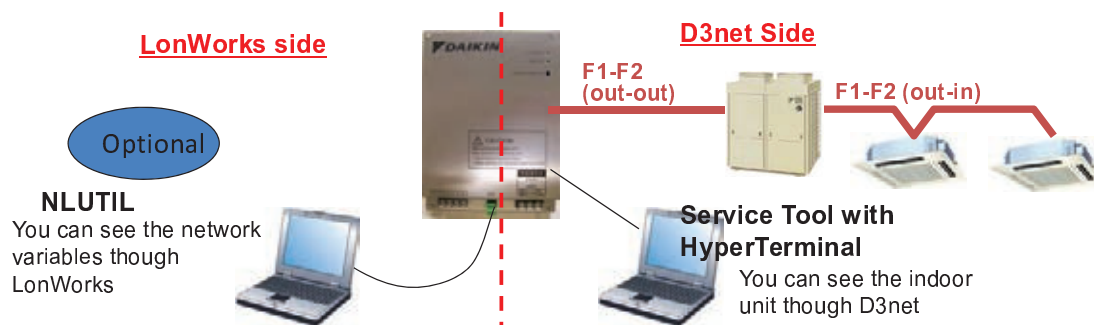

**NOTE:**  
VRV Indoor units must be group addressed for the LonWorks to communicate properly.

# LonWorks / VRV Architecture

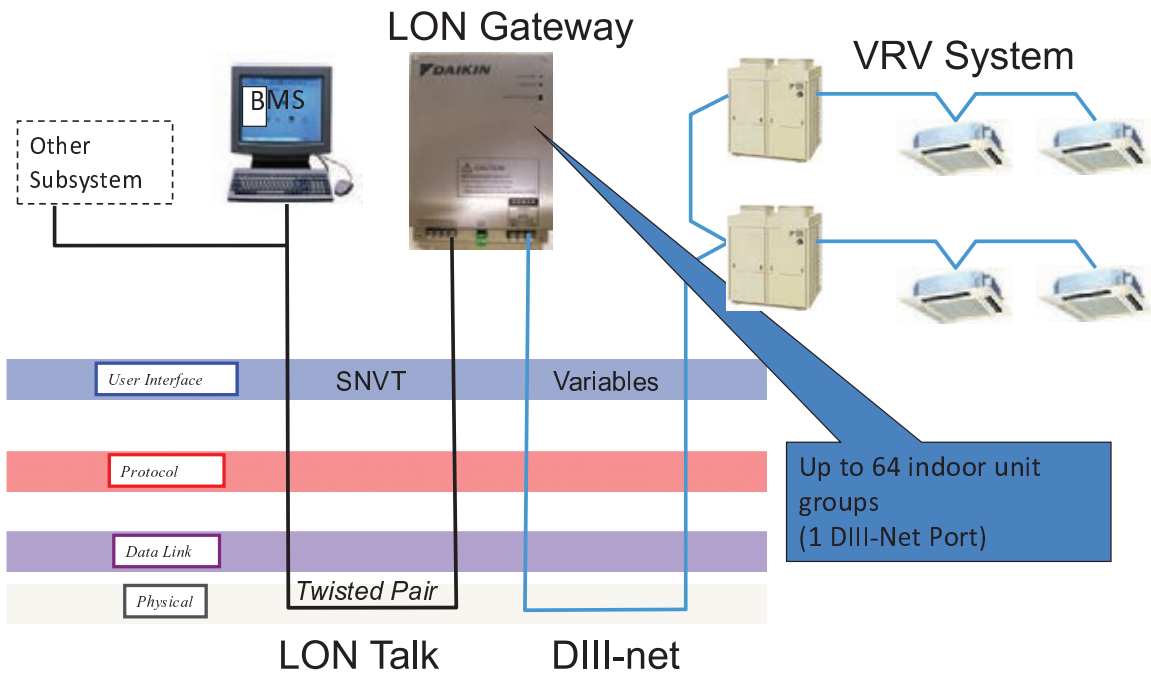

# LonWorks / VRV Architecture



## ■ System Configuration

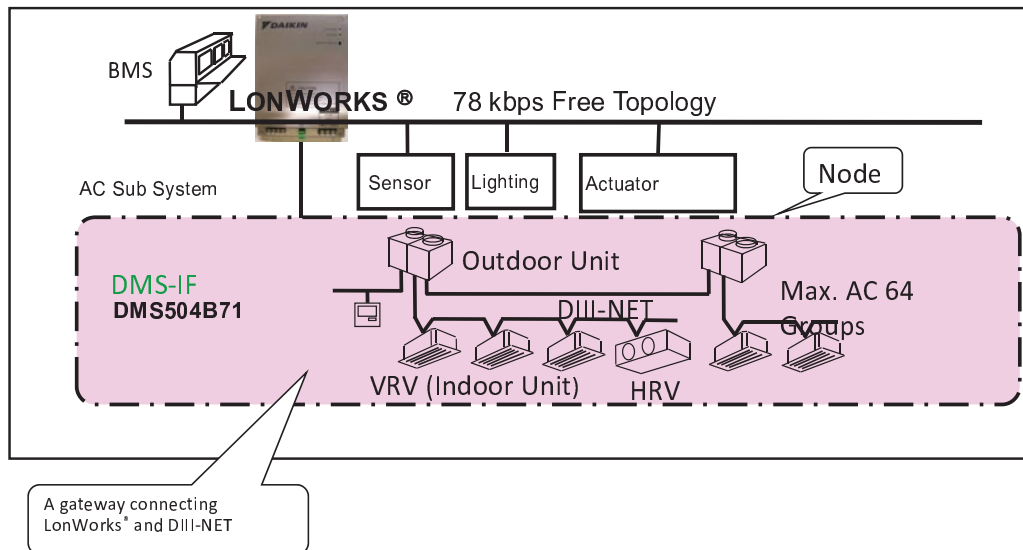

## Standard Network Variable Type – defined command points on the Lon network

	Function	Description
<b>Monitoring points</b>	ON / OFF Status	Monitors the start / stop status of the indoor unit.
	Operation Mode Status	Monitors whether the indoor unit is in the cooling, heating or fan mode.
	Temperature Setpoint	Reports the current temperature setpoint of the indoor unit.
	Room Temperature (Note 1)	Reports the current return air or room temperature of the indoor unit. (Note 1)
	Airflow rate	Reports the current fan speed setting of the indoor unit.
	Filter Indication Status	Reports the status of the filter maintenance icon on the indoor unit remote controller.
	Error Status	Monitors the indoor unit malfunction status.
	Error Code	Reports a specific malfunction code for an indoor unit in alarm state.
	Thermo Status	Reports whether the indoor unit is demanding heating or cooling capacity or if it is in a satisfied state.
	Forced Thermostat Off Status	Reports whether the indoor unit is forced to a satisfied state.
	Remote Controller ON / OFF Restriction Status	Indicates the restriction status of the indoor units remote controller ON / OFF button.
	Remote Controller Operating Mode Restriction Status	Indicates the restriction status of the indoor units remote controller operation mode button.
	Remote Controller Temperature Setpoint Restriction Status	Indicates the restriction status of the indoor units remote controller temperature setpoint buttons.
	System Forced OFF Setting Status	Monitors the system forced off status for all indoor units connected to the Lon gateway.
Sub-group Control Operation Restriction Setting Status	Monitors the network variable input status for permission / prohibition of centralized control devices on the DIII-Net bus.	
A/C Communication Status	Monitors the communication status of the indoor unit to the DIII-Net.	
<b>Operation, configuration, and control points</b>	ON / OFF Command	Starts and stops the indoor unit. (Note 2)
	Operating Mode	Sets the cooling / heating / ventilating / auto mode for the indoor unit. (Note 2)
	Temperature Setpoint	Commands the temperature setpoint for the indoor unit. (Note 2)
	Airflow Rate (Fan Speed)	Sets the fan speed (high, low) for the indoor unit. (Note 2)
	Filter Indicator Reset	Resets the filter maintenance indicator on the indoor unit.
	Forced Thermo OFF Setting	Forcibly stops all cooling or heating capacity for the indoor unit.
	Remote Controller ON / OFF Restriction Setting	Disables the operation of the indoor unit remote controller ON / OFF button.
	Remote Controller Operating Mode Restriction Setting	Disables the operation of the indoor unit remote controller MODE button.
	Remote Controller Temperature Setpoint Restriction Setting	Disables the operation of the indoor unit remote controller temperature setpoint buttons.
	System Forced OFF Setting	Forcibly stops / resets all indoor units that are under control of the Lon interface. Units cannot be started by a remote controller or centralized controller while in this state.
	Sub-group Control Restriction Setting	Network variable input to permit or prohibit the operation of Daikin centralized control devices on the DIII-Net bus.

= Control Items pertaining to the entire system

## Group Capacity Verses Quantity of Monitored Items

Control and Monitoring Items n (individual groups)	Max. number of groups connected	Remarks
23 items (All)	13 groups	-One LON can monitor up to 300 items. -The maximum number of control and monitoring items is 23 per A/C unit. If the number of control and monitoring items per A/C unit is assumed as 'n', the number of A/C groups connectable would be: <div style="border: 1px solid black; padding: 5px; width: fit-content; margin: 10px auto;"> <math display="block">\text{No. of A/C groups} \leq 300 \div n</math> </div> <Note: The maximum No. of A/C groups is 64.>
20 items	15 groups	
18 items	16 groups	
16 items	18 groups	
15 items	20 groups	
12 items	25 groups	
10 items	30 groups	
4 items	64 groups	

(Assuming that acknowledged service is 10 items per second on a 30-second interval data collection cycle.)

## Supporting LonWorks Integration Tasks

	iTouch Controller iTouch Manager	LON Gateway	BACnet Gateway
<b>Establish Point List</b> (each project)		Nothing (Just send XIF file)	(Create Point List) * Auto Discovery feature becoming commonplace
<b>Unit Addressing</b>	Set group address	Set group address	Set group address
<b>Setup and Configuration</b> (each project)	Set up (Partial List) <ul style="list-style-type: none"> <li>• Group Name Assignments</li> <li>• Zone Configuration</li> <li>• Limits Setting</li> <li>• Schedule Programming</li> </ul>	Set up <ul style="list-style-type: none"> <li>• Enable Battery Backup</li> </ul>	Set up (SetUpBACs tool) <ul style="list-style-type: none"> <li>• Instance Number</li> <li>• IP Addressing / Network Settings</li> <li>• Time and Date Setting / Time Zone</li> </ul>
<b>Commissioning</b> (each project)	Check Daikin System (iTC + VRV system)	Check Daikin System (LON GW + VRV system) <ul style="list-style-type: none"> <li>• Daikin DIII net configuration only</li> </ul>	Check Daikin System (BACnet GW + VRV system) <ul style="list-style-type: none"> <li>• Daikin DIII net configuration only</li> </ul>

## Wiring Terminations to the DMS504C71

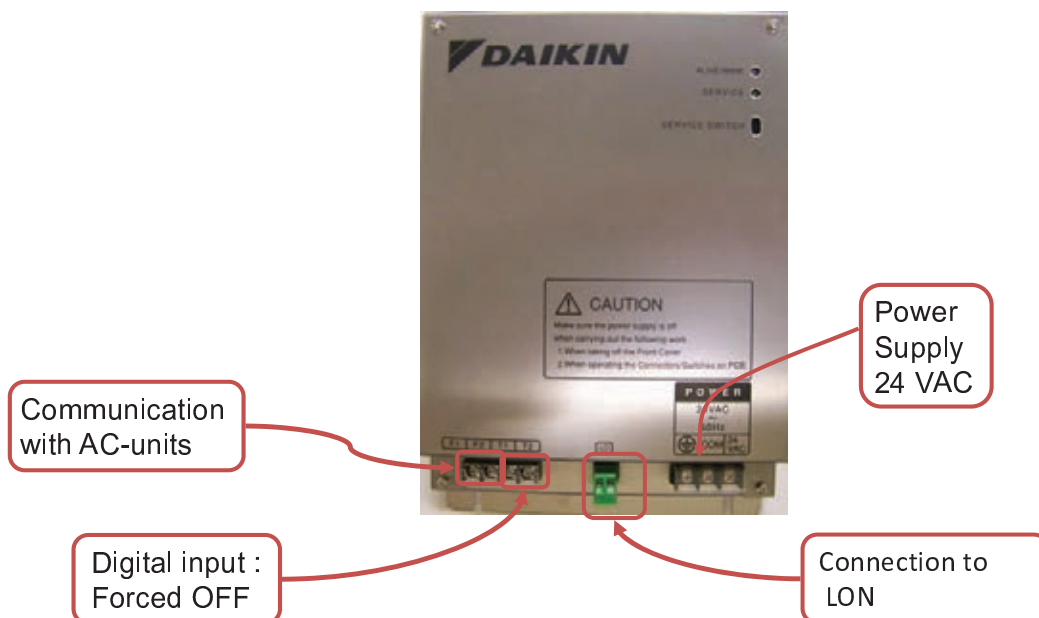

## Connecting to the DMS504C71 for Commissioning

### LonWorks gateway Connection with Laptop using "Cross Over" Serial Cable

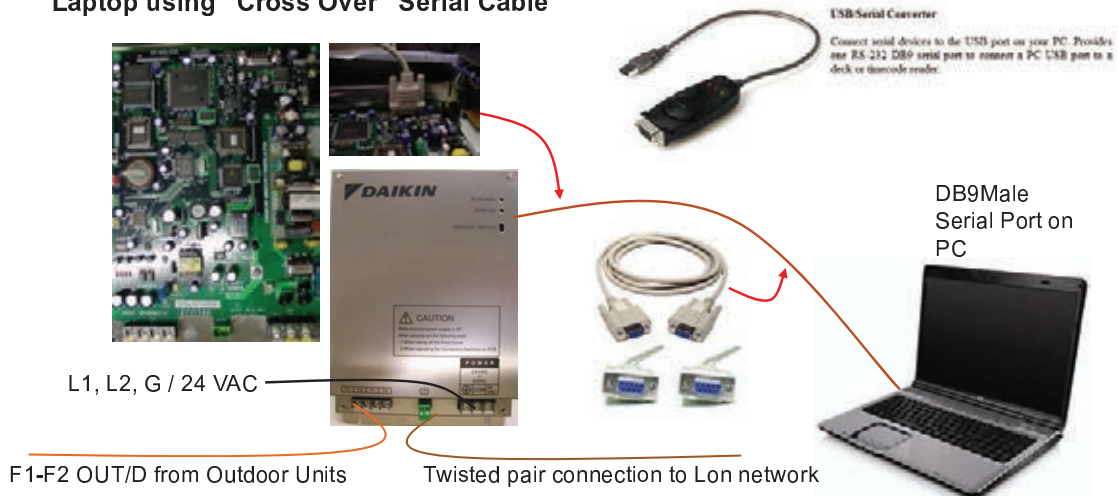

**Note: If your PC is not equipped with a serial port, a USB/Serial converter can be used in conjunction with the cross-Over serial cable as show above.**

## USB to LonWorks Network Interface

- LonWorks interface for USB enabled PC's (Windows XP)
- Also available in PCMCIA (PC Card) format
- The U10 USB Network Interface connects directly to a TP/FT-10 Free Topology Twisted Pair (ANSI/CEA-709.3) LONWORKS channel through a removable connector, and is fully compatible with link powered channels.
- Compatible with Lon network analyzer tools such as Newron System NLUtil.

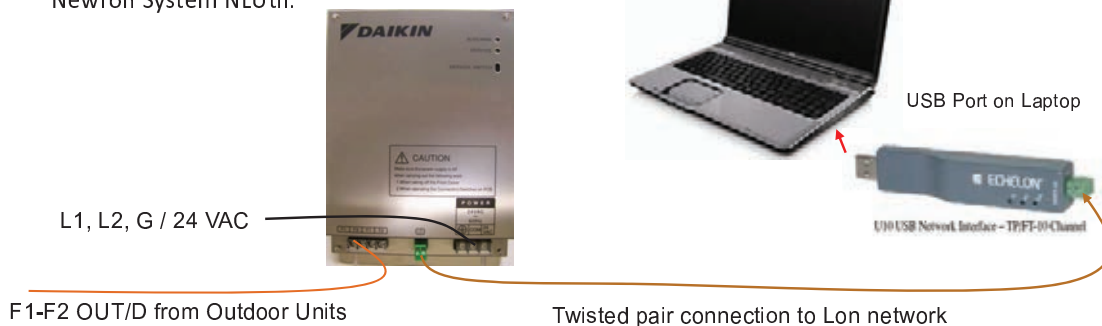



## LonWorks Gateway Configuration and Commissioning

- Refer to Daikin DMS-IF Commissioning Manual in Si72-305
  - Review of procedures for commissioning
  - Configuration of the PC used for commissioning
  - An overview of Windows® HyperTerminal application
  - Connection to the PC via RS232C Crossover cable
  - Operation Checks
  - Understanding terminal resistance and when to adjust
  - PC command functions
  
- Newron Systems – NLUtil Software Application
  - Analyze and diagnose LonWorks networks
  - Compliment to LonWorks networks as BACnet Explorer is to BACnet
  - Hands on demonstration

## Commissioning & Test Run

1. Check the DIII net
2. Internal battery & terminal resistance
2. Binding

## 1. Check the DIII net



**DMS504C71 only**

**IMPORTANT NOTE:**  
Windows Vista and Windows 7 does not come with HyperTerminal.  
A third party HyperTerminal program can be found on the internet.

# 1. Check the DIII net



**Select the appropriate COM port**

DMS504C71 only

# 1. Check the DIII net



```
1. Press enter
LONGW> _

2. Type (H) for Help

LONGW> (H)help with commands
H -- (H)elp with commands.
C -- (C)heck D3 NET Interface.
S -- (S)et AC : ON or OFF.
G -- (G)et AC Status : ON or OFF
R -- (R)estart LON Gateway.
N -- Print (N)etmap ID.
V -- Print (V)ersion Number.
L -- Print (L)og.
LONGW> _
```

DMS504C71 only

# 1. Check the DIII net



**3. Type (C) to check the DIII net (all should be OK)**

```
LONGW> (C)heck D3~NET Interface
      OK : D3 Master/Slave setting.
      OK : D3 address setting.
      OK : D3 Pole detection(photo coupler)
LONGW> _
```

- The LON G/W should be master
- No duplicate DIII addresses
- No LON G/W malfunction (M1 error)

Connected 0:00:08 | Auto detect | Auto detect | SCROLL | CAPS | NUM | Capture | Print echo

DMS504C71 only

# 1. Check the DIII net



**4. Type (S) to switch ON/OFF a unit**

```
LONGW> (S)et AC : ON or OFF
Which AC do you wish to set? (1-64) Enter :1
Enter 1(ON) or 0(OFF) for AC1 Enter :1
set AC1 ON Complete.
LONGW>
```

**5. Type (G) to see unit status**

```
LONGW> (G)et AC Status : ON or OFF
Which AC do you wish to see? (1-64) Enter :1
AC1 is: ON state.
LONGW> _
```

**Check all units**

**Make sure the forced of contact is not closed**

Connected 0:00:08 | Auto detect | Auto detect | SCROLL | CAPS | NUM | Capture | Print echo

DMS504C71 only

# 1. Check the DIII net



LON GW - HyperTerminal

File Edit View Call Transfer Help

6. Type (N) to see the Neuron Chip Identification

```
LONGW> Print (N)euron ID
NID is 4:6e:3f:f1:0:0
```

7. Type (V) to see the LON version

```
LONGW> Print (V)ersion Number
Ver.is 1.10
```

Neuron chip inside



DMS504C71 only

# 2. Internal battery & terminal resistance



Switch on the internal battery

DMS504B51



JP2 open & JP3 open: 0 ohm (default)  
JP2 close & JP3 open: 105 ohm  
JP2 close & JP3 close: 52.5 ohm

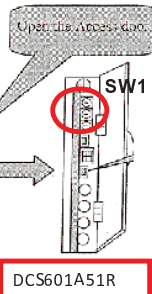
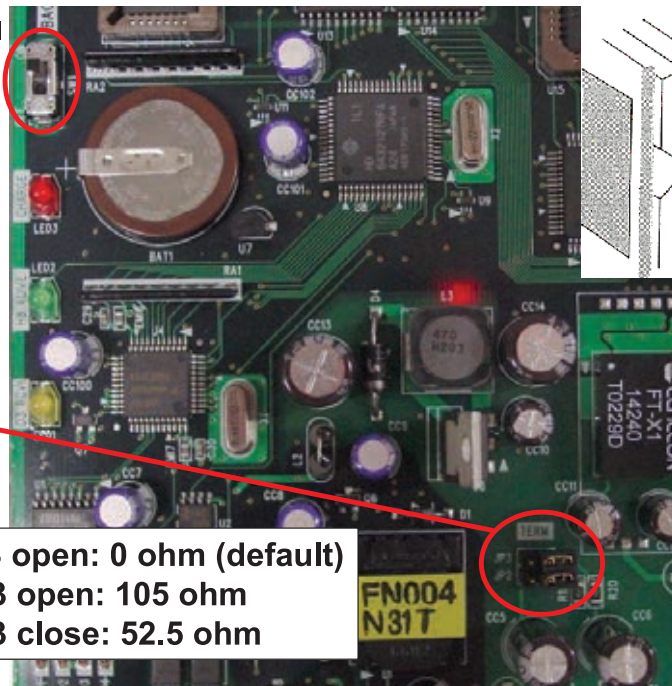

Set terminal resistance (only on request by BMS)

DMS504C71 only



### 3. Binding (optional)



- Binding\* Using Echelon's LONMaker®

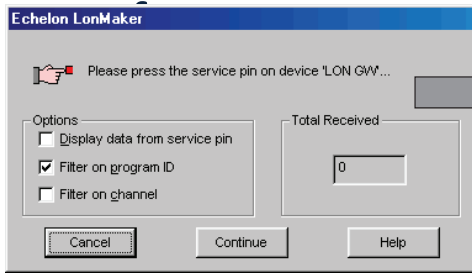

Service Switch:

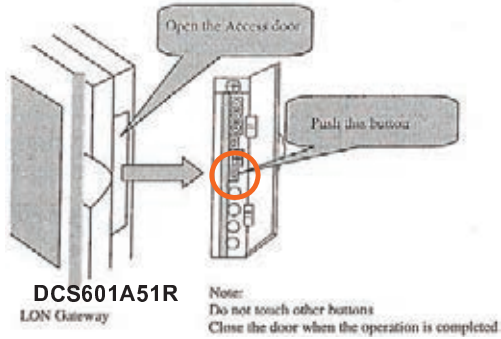

\* To be done by BMS

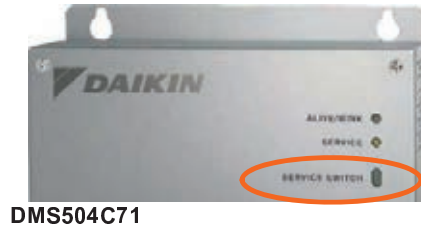
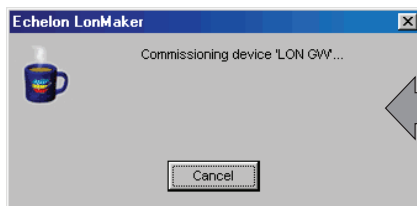

### 3. Binding (optional)



- Using Echelon's LONMaker® software (example)

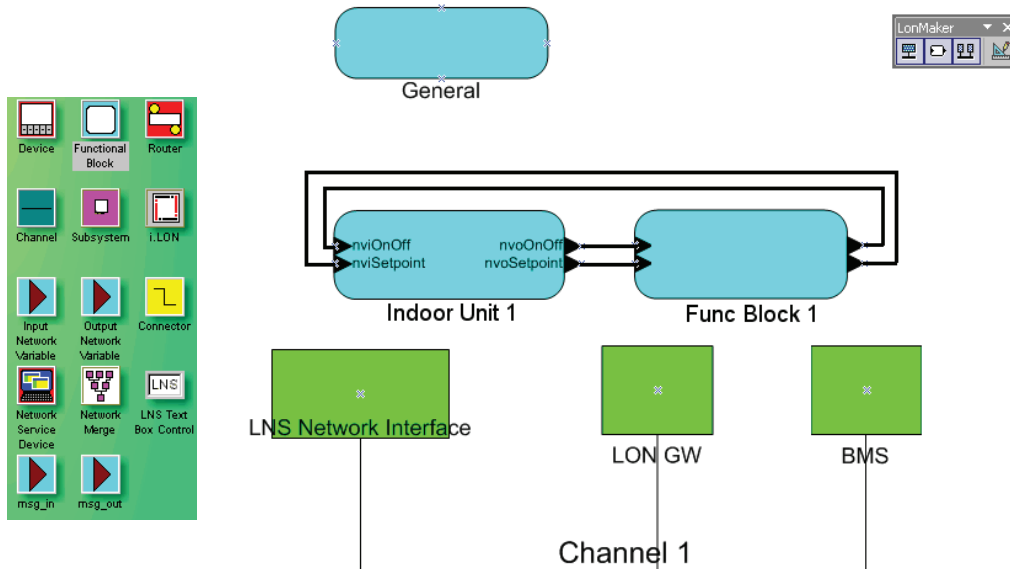

### 3. Binding (optional)



- Using Echelon's LONMaker® software (example)

The screenshot shows the LONMaker Browser software interface. The title bar reads "LONMaker Browser - Untitled". The menu bar includes "File", "Edit", "Browse", and "Help". Below the menu bar is a toolbar with various icons. A status bar at the top right shows "100.01". The main area contains a table with the following columns: Subsystem, Device, Functional Block, Network Variable, Config Prop, Mon, and Value.

Subsystem	Device	Functional Block	Network Variable	Config Prop	Mon	Value
Subsystem 1	LON GW	AC*	nvIFanSpeed_02		N	0,0 0
Subsystem 1	LON GW	AC*	nvIFSRReset_02		N	0,0 0
Subsystem 1	LON GW	AC*	nvIHeatCool_02		N	HVAC_AUTO
Subsystem 1	LON GW	AC*	nvIOnOff_02		N	0,0 0
Subsystem 1	LON GW	AC*	nvIRejMode_02		N	0,0 0
Subsystem 1	LON GW	AC*	nvIRejOnOff_02		N	0,0 0
Subsystem 1	LON GW	AC*	nvIRejSetpoint_02		N	0,0 0
Subsystem 1	LON GW	AC*	nvISetpoint_02		N	0,0 0
Subsystem 1	LON GW	AC*	nvIThermoOff_02		N	0,0 0
Subsystem 1	LON GW	AC*	nvOErrStatus_02		N	0,0 0
Subsystem 1	LON GW	AC*	nvOFailure_02		N	0,0 0
Subsystem 1	LON GW	AC*	nvOFanSpeed_02		N	100,0 1
Subsystem 1	LON GW	AC*	nvOFilterSign_02		N	0,0 0
Subsystem 1	LON GW	AC*	nvOHeatCool_02		N	HVAC_HEAT
Subsystem 1	LON GW	AC*	nvOHvacExist_02		N	0,5 1
Subsystem 1	LON GW	AC*	nvOOnOff_02		N	0,0 0
Subsystem 1	LON GW	AC*	nvORejMode_02		N	0,0 0
Subsystem 1	LON GW	AC*	nvORejOnOff_02		N	0,0 0
Subsystem 1	LON GW	AC*	nvORejSetpoint_02		N	0,0 0
Subsystem 1	LON GW	AC*	nvOSetpoint_02		N	22,0 0
Subsystem 1	LON GW	AC*	nvOSpaceTemp_02		N	327,6 7
Subsystem 1	LON GW	AC*	nvOThermo_02		N	0,0 0
Subsystem 1	LON GW	AC*	nvOThermoOff_02		N	0,0 0
Subsystem 1	LON GW	AC*	nvOVattmeter_02		N	255,255,255,255



*Thank You*





COMFORT FOR LIFE

**Navigation Remote Controller - BRC1E72**



# Display Mode - Overview



Configurable display mode – Detailed, Standard, and Simple **New**

Display Mode	Detailed	Standard	Simple <b>New</b>
Display image			
On/Off status on LED (LED blinks when an error is occurred)	X	X	X
Mode	X *1	X *1	X *1
Setpoint (Dual/Single)	X *2	X *2	X *2
Room temperature	X		X
Fan speed	X *3	X *3	X *3
Air flow direction (when a louver is available)	X		
Day and Time	X *3		
Status icon	X *3	X *3	
Key lock icon	X	X	
Error message	X	X	

\*1. OFF can be displayed instead of the operation mode while the unit is turned off with the field setting **NEW**

\*2. Can be removed from the display while the unit is turned off with a field setting **NEW**

\*3. Can be removed from the display with a field setting **Improved**

# Display Mode - Detailed



## Detailed Display

- The air flow direction, clock, and detailed selection items appear on the detailed display screen in addition to the items appearing on the standard display.

12. Air Flow Direction  
(Displayed only when the air conditioner is in operation.)

13. Current Day/time  
(12/24 hour time display)

14. Detailed selection

# Display Mode - Standard



## Standard display

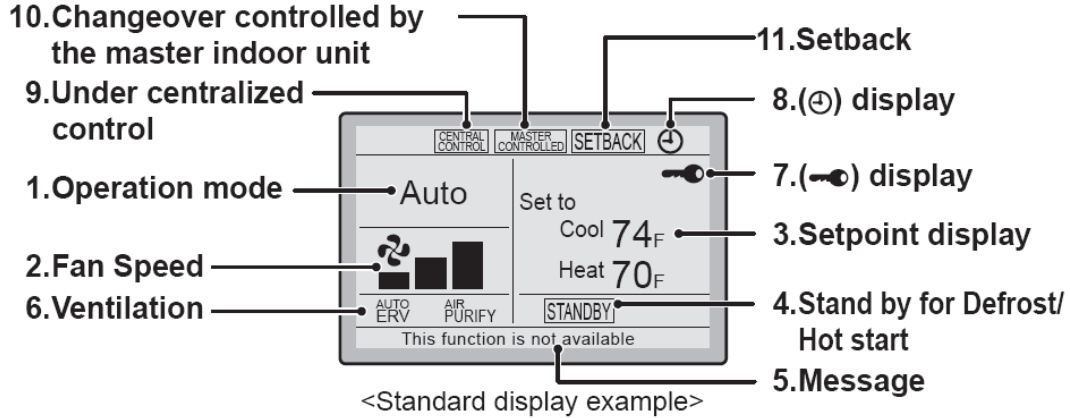

# Display Mode - Simple



## Simple Display

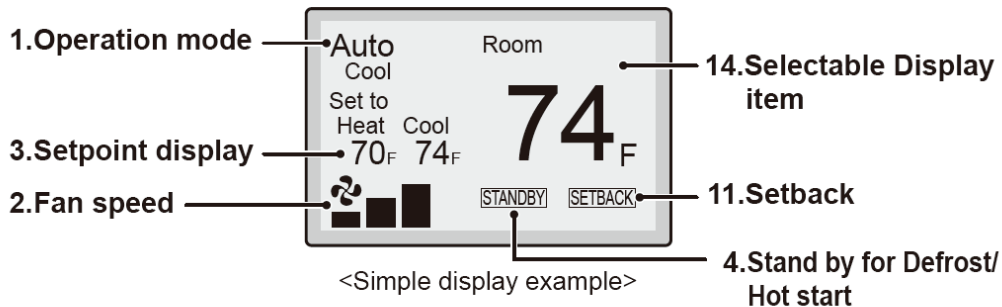

## Common precautions for all display modes

- Depending on the field settings, while the indoor unit is stopped, OFF may be displayed instead of the operation mode and/or the setpoint may not be displayed.

## Simple Display Variations - Single SP



Theme		Everything	No Mode Change	Fan Speed Fixed
LCD Display Image				
Optional Face Decal  Face Decal can be applied to Detailed and Standard display mode too.				
M: Mandatory, O: Optional setting		BRC1E72RMF	BRC1E72RF	BRC1E72RM
M	Display mode - Simple (Main menu)	X	X	X
M	Display item - Room Temp (Main menu)	X	X	X
M	Single setpoint (Srv Menu → Min Setpoint Diff - Single SP)	X	X	X
M	Prohibit Menu/OK and Cancel buttons (Special sequence required)	X	X	X
M	Mode button prohibit (Srv menu → Prohibit functions → Prohibit button)		X	
M	Fan icon display off (Field Setting 1b-15-02) Fan button also prohibited			X
O	Off display instead of Mode while the unit is off (Field setting 1b-13-02)	X	X	X
O	Erase setpoint display while the unit is off (Field setting 1b-12-02)	X	X	X

## Simple Display Variations - Dual SP



Theme		Everything	No Mode Change	Fan Speed Fixed
LCD Display Image				
Optional Face Decal  Face Decal can be applied to Detailed and Standard display mode too.				
M: Mandatory, O: Optional setting		BRC1E72RMF2	BRC1E72RF2	BRC1E72RM2
M	Display mode - Simple (Main menu)	X	X	X
M	Display item - Room Temp (Main menu)	X	X	X
M	Dual setpoint (Srv Menu → Min Setpoint Diff - 0 to 7F)	X	X	X
M	Prohibit Menu/OK and Cancel buttons (Special sequence required)	X	X	X
M	Mode button prohibit (Srv menu → Prohibit functions → Prohibit button)		X	
M	Fan icon display off (Field Setting 1b-15-02) Fan button also prohibited			X
O	Off display instead of Mode while the unit is off (Field setting 1b-13-02)	X	X	X
O	Erase setpoint display while the unit is off (Field setting 1b-12-02)	X	X	X

- **Following display configurations are available through field settings**

- Applicable to all three display models
- Display OFF instead of Mode while the unit is off (1b-13-02)
- No setpoint display while the unit is off (1b-12-02)
- No Fan Speed display (1b-15-02)

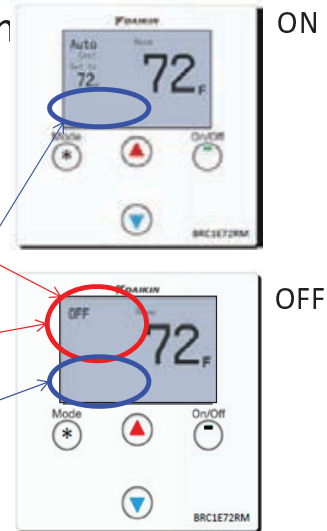

## Status Icon Elimination

- **Status icon and other information on the display can be eliminated through Field Setting**
  - e.g. “Central Control” icon is not necessary in hotel room

Item	Available Display mode			Field Setting	
	Detailed	Standard	Simple	Code	Choice
STSANDBY icon	X	X	X	1b-7	01: display in Defrost or Hot Start 02: Not display
Day/Clock	X			1b-11	01: display 02: Not display
CENTRAL CONTROL icons	X	X		1e-9	(MASTER CONTROL icon too) 01: display 02: Not display
Prohibit button message	X	X	X	1e-10	01: Key lock icon blinks for 5 sec (Key lock icon is not displayed in Simple display mode) 02: Message

- Operable arrow keys are indicated at the message area (Detailed, Standard display modes)

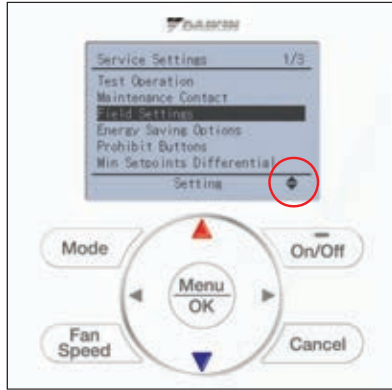

Up/Down arrow keys are available

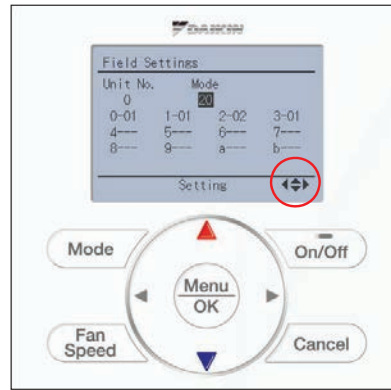

All four arrow keys are available

## BRC1E72 sensor Only - Field Settings

- To use only BRC1E72 sensor, set field settings as 10-2-03, 10-5-02, & 1C-1-02
- 10-2-03, 10-5-02 availability**
  - always available: FXMQ\_P, FXTQ\_P, FXAQ\_P, FXFQ\_P, FBQ\_P, FTQ\_P, FCQ\_PA
  - All \_M series (except FXFQ, FXHQ, FCQ, FHQ)
    - Manufactured after 9/1/2009: always available
    - Manufactured before 9/1/2009: confirm if 10-2-03, 10-5-02 are available.
  - never available: FXFQ\_MVJU, FXHQ\_MVJU, FCQ\_MVJU, FCQ\_PVJU, FHQ\_MVJU, FHQ\_PVJU
    - Set 10-2-02 and use Remote sensor (or Return air sensor) only
- Field setting – 10-2, 10-5 and 1C-1 settings are necessary

Which single sensor is used?	For indoor unit control (Cool/Dry/Heat VRV and thermo-on/off control)	For BRC1E72 control (Auto changeover and setback control)	For Multi-zone Control
BRC1E72	10-2-03	1C-1-02 (default)	10-5-02
Remote sensor (or Return air sensor)	10-2-02 (it is always available)	1C-1-01	10-5-01 (default)

**Recommended**

- **Event in the schedule is to carry out for the manual operation at the time.**
- **On Event – Set Cool and Heat setpoints**
  - Cool and/or Heat setpoints can be set. If none specified, the current setpoints are used.
- **Off Event – Set Setup and Setback setpoints**
  - Setup (for cooling) and/or Setback (for heating) setpoints can be set. If none specified, the current Setup/Setback setpoints are used.
  - You can also disable setup/setback control.

Schedule				
	Time	Act	Cool	Heat
WKDY	7:00 <sub>A</sub>	ON	—	—
	8:00 <sub>A</sub>	ON	74 <sub>F</sub>	—
	8:00 <sub>A</sub>	ON	74 <sub>F</sub>	68 <sub>F</sub>
	9:00 <sub>A</sub>	OFF	86 <sub>F</sub>	62 <sub>F</sub>
	10:00 <sub>A</sub>	OFF	-- <sub>F</sub>	—
Setting				

### Example

- ← No setpoints are specified, just turn on the unit with the latest setpoints
- ← Only cool setpoint is specified, the latest heat setpoint is used.
- ← Both cool and heat setpoints are specified.
- ← Both setup and setback setpoints are specified.
- ← No setup control (just turn off) and the latest setback setpoint is used.

No setpoint or setup/setback setpoint is specified. The latest value is used.

Disable setup/setback setpoint and the unit is kept turned off

- **Installation**
  - Cable Hole
  - Power on
  - Changeover master indoor unit
- **Menu manipulation**
  - Main Menu Structure
- **Initial Settings – Main Menu**
  - 1. Language
  - 2. DST
  - 3. Clock & Calendar
  - 4. Display Mode
  - 5. Celsius / Fahrenheit
- **Initial Settings – Service Settings**
  - Get into Service Settings Menu
  - Service Settings Structure
  - Field Settings
  - Group Address
  - 6. Enable Setback
  - 7. Setpoint Range
  - 8. Setback Recovery Differential
  - 9. Min. Setpoints Differential
  - 10. Prohibit R/C buttons
  - 11. Prohibit Mode
- **Schedule – Main Menu**
- **Child lock**

Main menu	2 <sup>nd</sup> menu	3 <sup>rd</sup> menu	Choice
Airflow Direction (if unit has a louver)			Swing, Position 0 to 4
Schedule	Enable/Disable		Enable, Disable
	Daily Patterns		7 Days, Weekday/Weekend, Weekday/Sat/Sun, Everyday
	Settings		Day, Time, Act ion(On/Off), Cool and Heat Setpoints
Off Timer	Enable/Disable		Enable, Disable
	Settings		30 to 180 mins (10 min increment)
Celsius / Fahrenheit			Celsius, Fahrenheit
Maintenance Information			(Display only)
Configuration	Contrast Adjustment		Dark to Light
	Display	Display mode	Detailed, Standard, Simple
		Display Item	Room Temp, Outside Air Temp, System, None
Current Settings			(Display only)
Clock & Calendar	Date & Time		Year, Month, Date, Time
	12H/24H Clock		12H, 24H
Daylight Saving Time	Enable/Disable		Enable, Disable
	DST Dates		Start Date, End Date
Language			English, Francais, Espanol

## Initial Setting – Language

- English (default) / French / Spanish selectable
- Language: Main Menu → Language

### Selectable Languages

#### Operation

1

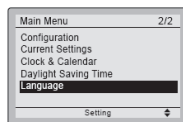

- Display the main menu screen. (See page 22.)
- Press ▼▲ buttons to select **Language** on the main menu screen and press the Menu/OK button.

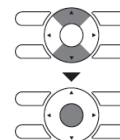

2

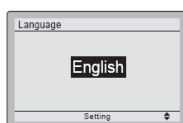

- Press ▼▲ buttons to select the preferred language on the language screen. English/Français/Español are available.
- Press Menu/OK button to confirm the settings and return to the basic screen.

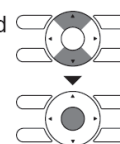



- DST: Main Menu → Daylight Saving Time

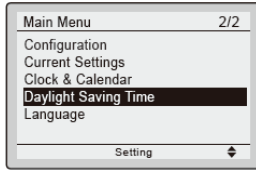

## Enabling or disabling Daylight Saving Time

**Operation**

- Display the Daylight Saving Time screen. (See page 42.)
  - Press the **▼▲** buttons to select **Enable/Disable** on the Daylight Saving Time screen. Press the Menu/OK button to display the Enable/Disable screen.
- Press the **▼▲** buttons to select **Enable** or **Disable** on the Enable/Disable screen.
  - Press the Menu/OK button to display the setting confirmation screen.
- Press the **◀▶** buttons to select **Yes** on the setting confirmation screen. Pressing the Menu/OK button confirms the Daylight Saving Time Enable/Disable setting and takes you back to the basic screen.

## Setting the date

**Operation**

- Display the Daylight Saving Time screen. (See page 42.)
  - Press the **▼▲** buttons to select **Dst Dates** on the Daylight Saving Time screen. Press the Menu/OK button to display the duration setting screen.
- Press the **▼▲** buttons to select a month from 12 months (January to December) for both Start and End.
  - Press the **◀▶** buttons to select a week from 5 weeks (1st Sunday to Last Sunday) for both Start and End.
  - \*When you set the last week for a month that does not have the Sunday in the fifth week, the Sunday in the fourth week will be set for the switching day.
  - After setting the Start and End dates, press the Menu/OK button to display the setting confirmation screen.
- Press the **◀▶** buttons to select **Yes** on the setting confirmation screen. Pressing the Menu/OK button confirms the Daylight Saving Time settings and takes you back to the basic screen.

### When Daylight Saving Time is enabled

When the clock in the remote controller reaches 2:00 a.m. on the specified start date, the clock is automatically set forward by one hour. When the clock in the remote controller reaches 3:00 a.m. on the end date, the clock is automatically set back by one hour.

- Date & Time: Main Menu → Clock & Calendar
  - Select 12H or 24H. (12H as default)
  - Setup Date & Time accordingly

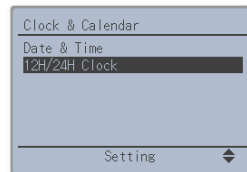

### 12H/24H CLOCK

**Operation**

- Display the clock & calendar screen. (See page 39.)
  - Press **▼▲** buttons to select **12H/24H Clock** on the Clock & Calendar screen. The 12H/24H clock screen will appear when the Menu/OK button is pressed.
- By default, the time display is set to the 12H format.
  - Press **▼▲** buttons to select **12H** or **24H** on the 12H/24H clock screen.
  - The confirmation screen will appear when the Menu/OK button is pressed.
- Press **◀▶** buttons to select **Yes** on the confirmation screen. Pressing the Menu/OK button confirms the 12H or 24H and takes you back to the main menu screen.

### Date & Time

**Operation**

- Display the main menu screen. (See page 22.)
  - Press **▼▲** buttons to select **Clock & Calendar** on the main menu screen. Press Menu/OK button to display the clock & calendar screen.
- Press **▼▲** buttons to select **Date & Time** on the clock & calendar screen. Press Menu/OK button to display the date & time screen.
- Select "Year" with **◀▶** buttons. Change the year with **▼▲** buttons. Holding down the button causes the number to change continuously.
- Select "Month" with **◀▶** buttons. Change the month with **▼▲** buttons.

(To be continued)

## Initial Setting – Display Mode



- Main Menu → Configuration → Display → Display Mode

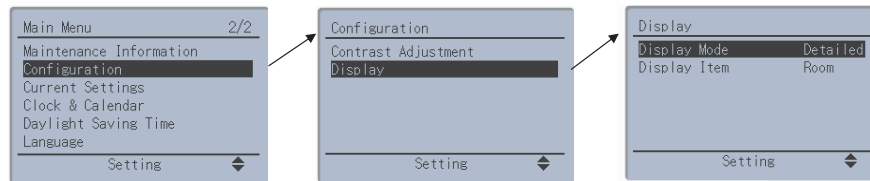

Detailed

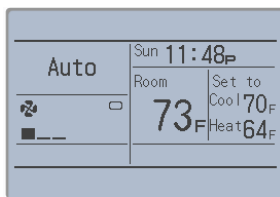

Standard

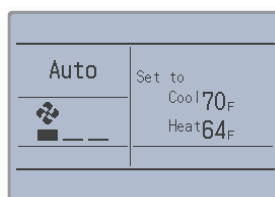

Simple



## Initial Setting – Celsius/Fahrenheit



- Fahrenheit is default
- Main Menu → Celsius / Fahrenheit

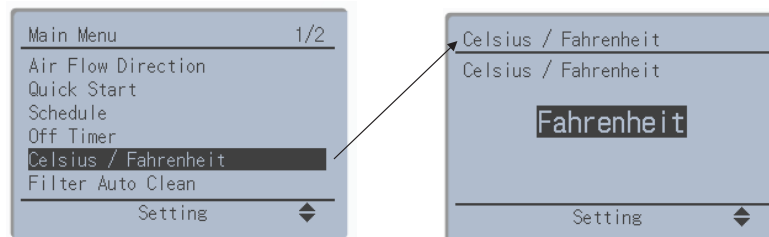

## Get into Service Settings Menu



- Push any key to activate backlight
- Hold Cancel button for 4 seconds, and you can see Service Settings Menu

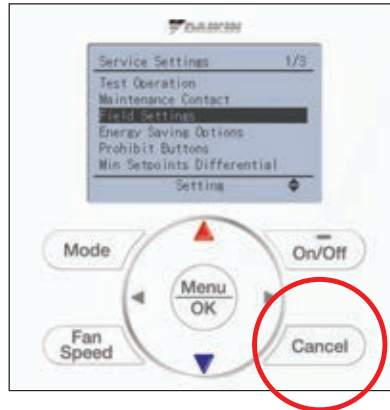

Hold for 4 seconds

## Service Setting Menu Structure



Service Setting menu	2 <sup>nd</sup> menu	Choice
Test Operation		
Maintenance Contact	None	
	Maintenance Contact	Tel Numbers
Field Settings		Field Settings
Energy Saving Options	Setpoint Range Limitation	Cool Setpoint Range, Heat Setpoint Range
	Setback Configuration	Cool Recovery Differential, Heat Recovery Differential
Prohibit Function	Prohibit Buttons	Enable, Disable, Disable in Off in each button
	Prohibit mode	Enable, Disable in each mode
Min Setpoints Differential		0 to 8F, Single SP, None
Group Address (if multizone controller is connected)	Group Address (Group)	Group Address
	Group Address (Unit)	Unit No, Group Address
Indoor unit AirNet Address		Unit No. Address
Error History	RC Error History	(Display only)
	Indoor unit Error History	(Display only)
Indoor Unit Status		(Display only)
Outdoor Unit Status		(Display only)
Forced Fan ON		Unit No
Switch Main Sub Controller		Main RC, Sun RC
Filter Indicator		ON, OFF

# Field Settings – Indoor unit



## Field Settings – Indoor Units (Control Related)

(Light blue highlighted items are default settings)

Mode No. (Note 1)	First Code No.	Description	Second Code No. (Note 2) (Cells in bold are factory default settings)			
			01	02	03	04
10(20)	2	Priority of thermistor sensors for space temperature control	The return air thermistor is primary and the remote controller thermistor is secondary.	Only the return air thermistor will be utilized.	Only the remote controller thermistor will be utilized.	--
	5	Room temperature value reported to multizone controllers	Return air thermistor	Thermistor designated by 10-2 above (Note 3)	--	--
	6	The remote controller thermistor is used in Remote Controller Group	No	Yes	--	--
12(22)	0	KRP1B71 X1-X2 status output	Indoor unit Thermo-On/Off status	--	Indoor unit Operation On/Off status	Indoor unit Alarm status
	1	Indoor unit T1-T2 input	Forced Off  Closed Contact-Indoor unit is forced off and Central Control icon is displayed. Unit cannot be turned on manually. Operation can be overridden by central control.  Open Contact-Indoor unit can resume normal operation. Unit must be turned on manually or by central control.	On/Off  Closed Contact-Indoor unit is turned on.  Open Contact-Indoor unit is turned off.  Unit responds to last command, i.e., unit can be turned on manually or by central control after circuit has opened. Operation is prohibited when remote controller On/Off control is restricted by a multizone controller.	External Protection Device  Closed contact-Unit shall resume normal operation.  Open contact-Unit shall shut down and generate an A0 error.	
	2	Thermo-On/Off deadband (Note 4)	2F (1C)	1F (0.5C)	--	--
	3	Fan Speed in Heating Thermo-Off	LL	User set	Off	--
	6	Fan Speed in Cooling Thermo-Off	LL	User set	Off	--
	8	Return air sensor offset	2C	None (for remote sensor)		

- Field settings are normally applied to the entire remote control group, however if individual indoor units in the remote control group require specific settings or for confirmation that settings have been established, utilize the mode number in parenthesis.
- Any features not supported by the installed indoor unit will not be displayed.
- When mode 10-2-01 is selected, only the return air temperature value is reported to the multizone controller.
- The actual default deadband value will depend upon the indoor unit model.

## Field Setting Availability by Indoor unit type



### Availability of Indoor Unit Field Settings (Control Related)

As of 12/01/2012

Mode No.	10					12					
	2	03	5	6	0	1	2 (***)	3	03	6	8
First Code No.	01/02	03	01/02	01/02	01/02/04	01/02/03	01/02	01/02	03	01/02/03	01/02
Second Code No.	01/02	03	01/02	01/02	01/02/04	01/02/03	01/02	01/02	03	01/02/03	01/02
FXSQ_MVJU	X	X**	X**	X	X	X	X (02)	X	X**	X*	n/a
FXMQ_MVJU	X	X*	X*	X	X	X	X (02)	X	X*	X*	n/a
FXMQ72/96MVJU	X	X	X	X	X	X	X (02)	X	X	X	n/a
FXMQ_PVJU	X	X	X	X	X	X	X (02)	X	X	X	n/a
FBQ_PVJU	X	X	X	X	X	X	X (02)	X	X	n/a	n/a
FXDQ_MVJU	X	X	X	X	X	X	X (02)	X	X	n/a	n/a
FXTQ_PVJU	X	X	X	X	X	X	X (02)	X	X	X	n/a
FTQ_PAVJU	X	X	X	X	X	X	X (02)	X	X	X	n/a
FTQ_PBVJU	X	X	X	X	X	X	X (02)	X	X	X	n/a
BEQ_MVJLR1 (FXOQ)	X	X	X	X	X	X	X (02)	X	X	X*	n/a
FXLQ_MVJU	X	X*	X*	X	X	X	X (02)	X	X*	X*	n/a
FXNQ_MVJU	X	X*	X*	X	X	X	X (02)	X	X*	X*	n/a
FXAQ_MVJU	X	X*	X*	X	n/a	X	X (01)	X	X*	n/a	n/a
FAQ_MVJU	X	X*	X*	X	n/a	X	X (01)	X	X*	n/a	n/a
FAQ_PVJU	X	X	X	X	n/a	X	X (01)	X	X	n/a	n/a
FXZQ_M7VJU	X	X*	X*	X	X	X	X (01)	X	X*	X*	n/a
FXFQ_MVJU	X	n/a	n/a	n/a	X	X	X (01)	X	n/a	n/a	n/a
FCQ_MVJU	X	n/a	n/a	n/a	X	X	X (01)	X	n/a	n/a	n/a
FCQ_PVJU	X	n/a	n/a	n/a	X	X	X (01)	X	n/a	n/a	n/a
FXFQ_PVJU	X	X	X	X	X	X	X (01)	X	X	X	X
FCQ_PAVJU	X	X	X	X	X	X	X (01)	X	X	X	X
FXHQ_MVJU	X	n/a	n/a	n/a	X	X	X (01)	X	n/a	n/a	n/a
FHQ_MVJU	X	n/a	n/a	n/a	X	X	X (01)	X	n/a	n/a	n/a
FHQ_PVJU	X	n/a	n/a	n/a	X	X	X (01)	X	n/a	n/a	n/a

\* Field settings highlighted in orange may not be available in units manufactured before 9/1/2009.

\*\* Field settings highlighted in blue may not be available in units manufactured before 1/1/2007.

\*\*\* Factory default value is indicated in parenthesis.

# Field Settings – BRC1E72



## Field Settings – BRC1E72 (Green highlighted items are new from BRC1E71) (Light blue highlighted items are default settings)

Mode No.	First Code No.	Description	Second Code No. (Cells in bold are factory default settings)						
			01	02	03	04			
1b	7	STANDBY icon	Display in Defrost or Hot Start		Not Displayed				
	11	Day/Clock	Displayed		Not Displayed				
	12	Setpoint display while the unit is off	Displayed		Not Displayed				
	13	Mode display while the unit is off	Displayed		Display OFF instead of the mode				
	14	Fan Speed button configuration	Fan Speed		Fan ON/Auto (Fan LL in thermo-off) <b>(Applicable to SkyAir only)</b>		FAN ON/Auto (Fan Off in thermo-off) <b>(Applicable to SkyAir only)</b>		
1c	1	Thermistor sensor used for Auto-changeover and Setback control	Return Air Thermistor – return air temperature displayed on controller as room temperature		Remote controller Thermistor – remote controller temperature displayed on controller as room temperature				
	10	Temperature Sensor Offset	01: -5.4°F (-3.0°C) <b>13: -8.4°F (-3.0°C)</b>	02: -4.5°F (-2.5°C) <b>12: -4.5°F (-2.5°C)</b>	03: -3.8°F (-2.0°C) <b>11: -3.8°F (-2.0°C)</b>	04: -2.7°F (-1.5°C) <b>16: -2.7°F (-1.5°C)</b>	05: -1.8°F (-1.0°C)	06: -0.9°F (-0.5°C)	07: 0.0°F (0.0°C)
1e	2	Setback availability	N/A		Heating mode only		Cooling mode only		Cooling/ Heating modes
	4	Schedule and Auto-changeover enabled when multizone controller is detected (Note 1)	No		Yes		--		--
	9	CENTRAL CONTROL icon	Not displayed		Displayed when under control by a multizone controller				
	10	Message when button pushed which has been prohibited by a multizone controller	Key lock icon blinks for 5 seconds		Message displayed on screen: "Under Centralized Control. Adjustments at the remote control are being restricted."				
	11	Auto changeover guard timer	15 min		30 min		80 min		90 min
	12	Auto changeover point	0.9°F (0.5°C)		1.8°F (1.0°C)		2.7°F (1.5°C)		3.6°F (2.0°C)
	13	Quick changeover point beyond the auto changeover point	0.9°F (0.5°C)		1.8°F (1.0°C)		2.7°F (1.5°C)		3.6°F (2.0°C)

1. Native remote controller Schedule and Auto-changeover functions are disabled when a multizone controller is detected and a group address is assigned.

# Initial Setting – Enable Setback



- **Field setting is available in the Service Settings**
  - Setback function is disabled (1e-2-01) by default
  - To enable it, set 1e-2-04

## Initial Setting – Setpoint Range



- **Service Settings → Energy Saving Options → Setpoint Range Limitation**

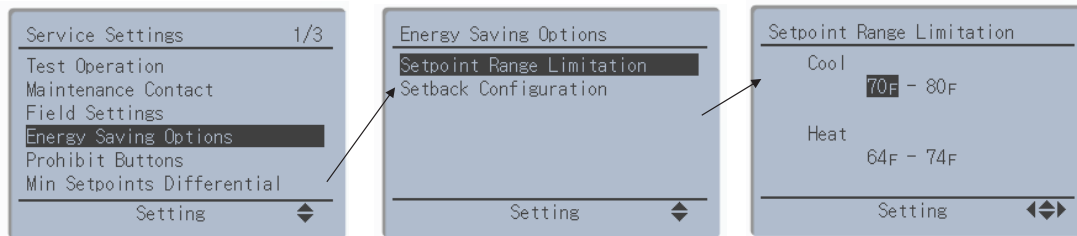

- **User can change the setpoint within the range**
- **Setup setpoint is configurable between**  
“Cool setpoint max + 2°F (1°C)” and “95°F”
- **Setback setpoint is configurable between**  
“Heat setpoint min – 2°F (1°C)” and “40°F”

## Initial Setting – Setback Recovery Differential



- **Service Settings → Energy Saving Options → Setback Configuration**
  - Setback Configuration won't be available if you have not enabled the setback control (Field setting 1e-2-04 is necessary).
- **Determine the point when unit is turned off again from the setback control (the unit is turned on by setback control when room temperature is above the setup setpoint or below the setback setpoint)**
  - Setup setpoint - 4°F as default (2 - 10°F selectable)
  - Setback setpoint + 4°F as default (2 - 10°F selectable)

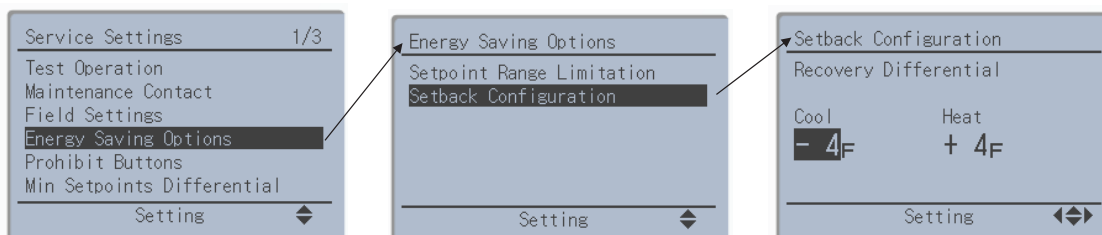

## Initial Setting – Min. Setpoints Differential



- Service Settings → Min Setpoints Differential
- Configurable to 0 – 8°F (0 – 4°C), default is 2°F (1°C) for Dual SP or Single SP

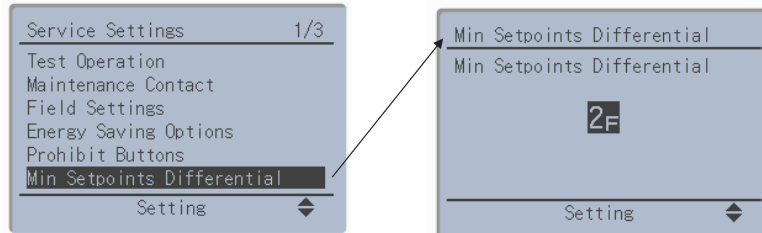

- When the differential is set to 0 – 8F, Cool and Heat setpoints are maintained as
  - Cool setpoint  $\geq$  Heat setpoint + Differential
- When Single SP is set, there is one setpoint for Cool and Heat
- When a multizone controller is connected, the differential is set to Single SP automatically.

## Initial Setting – Prohibit R/C buttons



- To configure which buttons to prohibit
  - Service Setting → Prohibit Functions → Prohibit Buttons
    - Enable = permit
    - Disable = prohibit
    - Disable in Off = prohibit only while the unit is off
- To enable Prohibit Buttons – see next slide



○ Operable buttons

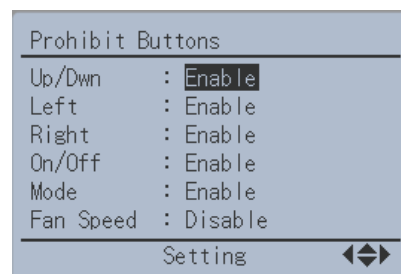

Menu/OK and Cancel button will be prohibited when any of the buttons are prohibited.

## Enable/Disable Prohibit Buttons



- To enable Prohibit Buttons, holding Right arrow button, push Mode, Fan Speed and Cancel at the same time while the main screen is displayed
- To release it, same as above
- Then if you push prohibited button, you will see a key icon blinking three times
  - Key icon is available in Detailed and Standard display mode only (In simple display mode Key icon is not displayed)

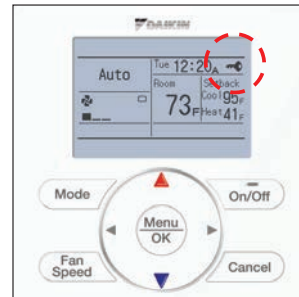
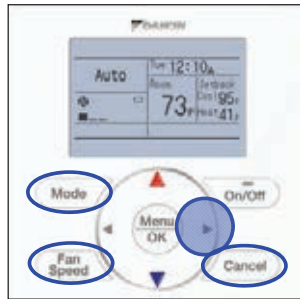

These buttons can be pressed from above the optional Face Decals to enable/disable prohibit buttons

## Initial Setting – Prohibit Mode



- To configure modes which cannot be selected by a user
  - Service Setting → Prohibit Functions → Prohibit Mode
  - Enable = selectable, Disable = not selectable

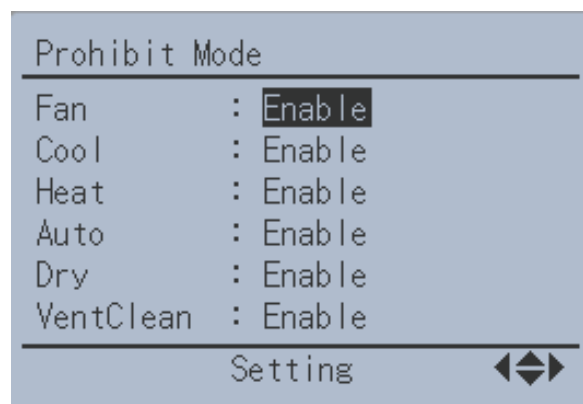



- Fan Speed button can be configured to Fan On/Auto button with the field setting
- **This can be used for SkyAir only**
  - 12-3-01/02/03, 12-6-01/02/03 should be available
- **Field setting**

	Fan Speed	Fan ON/Auto	
Fan Speed button configuration	<b>1b-14-01</b> (default)	<b>1b-14-02</b> Fan LL in thermo-off	<b>1b-14-03</b> Fan Off in thermo-off

- To Identify each indoor unit on the Service checker, D-Net (AirNet) address setting is available in Service Settings

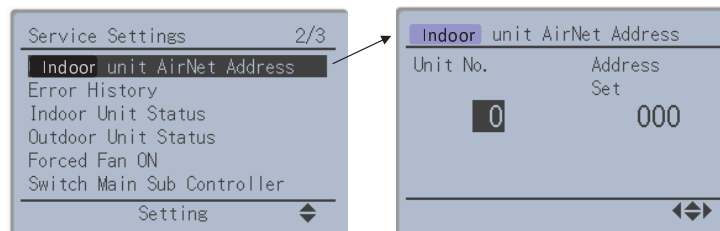



COMFORT FOR LIFE

*Thank You*