

HEATING INPUT: 45,000–113,000 BTU/H



Standard Features

- ComfortNet™ Communicating Systems compatible
- Heavy-duty Million-Air® stainless-steel dual-diameter, tubular heat exchanger
- Stainless-steel secondary heat exchanger
- Two-stage gas valve provides quiet, economical heating
- Durable SureStart™ Silicon Nitride igniter
- Quiet two-speed induced draft blower
- Utilizes ComfortNet™ communicating, two-stage or single-stage thermostats
- Self-diagnostic control board with constant memory fault code history output to a dual 7-segment display
- Color-coded low-voltage terminals with provisions for electronic air cleaner and humidifier
- Efficient and quiet variable-speed airflow system gently ramps up or down according to heating or cooling demand
- Multiple continuous fan speed options offer quiet air circulation
- Auto-Comfort and enhanced dehumidification modes available
- All models comply with California Low NOx emissions standards

Cabinet Features

- Certified for direct vent (2-pipe) or non-direct vent (1-pipe)
- Easy-to-install top venting with optional side venting
- Designed for multi-position installation — AMVC95: Upflow, horizontal left or right ACVC95: Downflow, horizontal left or right
- Convenient left or right connection for gas and electrical service
- Cabinet air leakage ($Q_{Leak} \leq 2\%$)
- Heavy-gauge steel cabinet with durable baked-enamel finish
- Fully insulated heat exchanger and blower section
- Airtight solid bottom or side return with easy-cut tabs for effortless removal in bottom air-inlet applications

Contents

Nomenclature.....2
 Product Specifications3
 Dimensions4
 AMVC95 Airflow Specifications6
 ACVC95 Airflow Specifications9
 Wiring Diagram.....11
 Accessories12



* Complete warranty details available from your local dealer or at www.amana-hac.com. To receive the Lifetime Unit Replacement Limited Warranty, the Lifetime Heat Exchanger Limited Warranty (good for as long as you own your home) and the 10-Year Parts Limited Warranty, online registration must be completed within 60 days of installation. Online registration is not required in California or Québec.



NOMENCLATURE

	A	M	V	C	95	070	4	C	X	A	A	
	1	2	3	4	5,6	7,8,9	10	11	12	13	14	
Brand	Amana® Brand										Revisions	
											A	Initial Releases (Major & Minor)
											B	1st Revisions (Major & Minor)
											C	2nd Revisions
Airflow Direction											NOx	
C	Downflow/Horizontal										N	Natural Gas
D	Dedicated Downflow										X	Low NOx
H	High Airflow										Cabinet Width	
K	Dedicated Upflow										A	14"
M	Upflow/Horizontal										B	17½"
											C	21"
											D	24½"
Description/Motor											Maximum CFM @ 0.5" ESP	
V	Two-Stage/Variable-speed										3	1200
H	Two-Stage/Multi-speed										4	1600
S	Single-Stage/Multi-speed										5	2000
E	Two-Stage/High-Efficiency										MBTU/h	
SystemType											045:	45,000
C	ComfortNet™ Communicating System										070:	70,000
											090:	90,000
											115:	115,000
											140:	140,000
AFUE												
95	95%											
9	90%+											
8	80%											

SPECIFICATIONS

	AMVC95 0453BXB*	AMVC95 0704CXB*	AMVC95 0905CXB*	AMVC95 0905DXB*	AMVC95 1155DXB*	ACVC95 0714CXB*	ACVC95 0915DXB*	ACVC95 1155DX
HEATING CAPACITY								
High Fire Input ¹	45,000	68,000	90,000	90,000	113,000	68,000	90,000	113,000
High Fire Output ¹	43,200	65,300	86,500	86,500	108,600	64,600	85,500	105,100
Low Fire Input ¹	31,500	47,600	63,000	63,000	79,100	47,600	63,000	79,100
Low Fire Output ¹	30,300	45,700	60,500	60,500	76,000	45,200	59,900	73,600
AFUE ²	96.1	96.1	96.1	96.1	96.1	95	95	93
Tons AC @ 0.5" ESP	1.5 - 3.0	1.5 - 4.0	2.0 - 5.0	2.0 - 5.0	2.0 - 5.0	1.5 - 4.0	2.0 - 5.0	2.0 - 5.0
Temperature Rise Range (°F)	30 - 60	30 - 60	30 - 60	30 - 60	35 - 65	25-55	25-55	40 - 70
CIRCULATOR BLOWER								
Size (D x W)	10" X 8"	10" X 10"	11" X 10"	11" X 10"	11" X 10"	10" X 10"	11" X 10"	11" X 10"
Horsepower @ 1050 RPM	½	¾	1	1	1	¾	1	1
Speed	Variable	Variable	Variable	Variable	Variable	Variable	Variable	Variable
Vent Diameter ³	2"	2"	3"	3"	3"	2"	3"	3"
No. of Burners	2	3	4	4	5	3	4	5
Disposable Filter (in ²)	422	657	844	844	1,079	749	961	864
ELECTRICAL DATA								
Min. Circuit Ampacity (amps) ⁴	11.3	14.1	14.4	14.4	14.4	11.2	15.1	14.4
Max. Overcurrent Protection ⁵	15	15	15	15	15	15	15	15
SHIP WEIGHT (LBS)								
	123	142	150	155	165	139	158	160

¹ Natural Gas BTU/h

² DOE AFUE based upon Isolated Combustion System (ICS)

³ Installer must supply one or two PVC pipes: one for combustion air (optional) and one for the flue outlet (required). Vent pipe must be either 2" or 3" in diameter, depending upon furnace input, number of elbows, length of run and installation (1 or 2 pipes). The optional Combustion Air Pipe is dependent on installation/code requirements and must be 2" or 3" diameter PVC.

⁴ Minimum Circuit Ampacity = (1.25 x Circulator Blower Amps) + ID Blower amps. Wire size should be determined in accordance with National Electrical Codes. Extensive wire runs will require larger wire sizes.

⁵ Maximum Overcurrent Protection Device refers to maximum recommended fuse or circuit breaker size. May use fuses or HACR-type circuit breakers of the same size as noted.

NOTES

- All furnaces are manufactured for use on 115 VAC, 60 Hz, single-phase electrical supply.
- Gas Service Connection ½" FPT
- Important: Size fuses and wires properly and make electrical connections in accordance with the National Electrical Code and/or all existing local codes.

AMVC95 DIMENSIONS

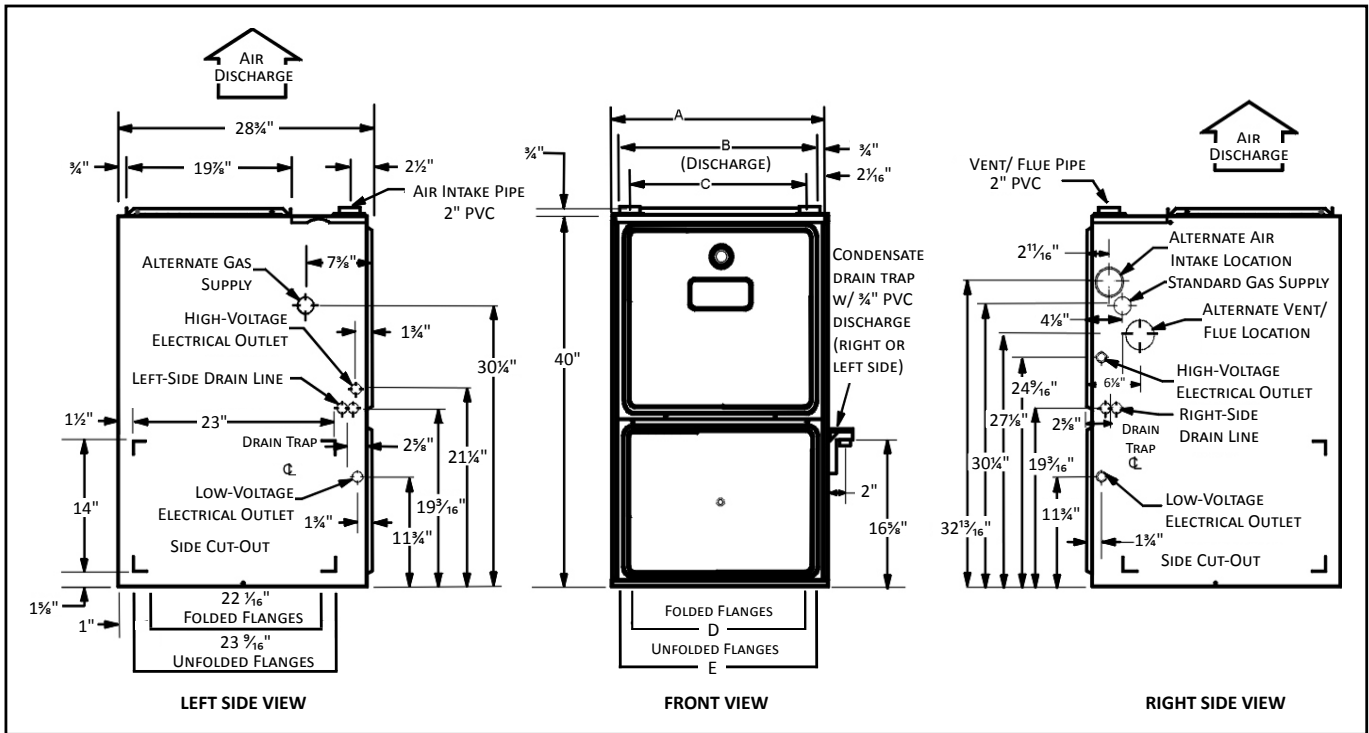

MODEL	A	B	C	D	E
AMVC950453BxB*	17 1/2"	16"	13 7/8"	12 5/8"	13 3/8"
AMVC950704CxB*	21"	19 1/2"	16 7/8"	16"	17 1/2"
AMVC950905CxB*	21"	19 1/2"	16 7/8"	16"	17 1/2"
AMVC950905DxB*	24 1/2"	19 1/2"	16 7/8"	16"	17 1/2"
AMVC951155DxB*	24 1/2"	23"	20 3/8"	19 3/8"	20 3/8"

NOTES:

- Installer must supply one or two PVC pipes: one for combustion air (optional) and one for the flue outlet (required). Vent pipe must be either 2" or 3" in diameter, depending upon furnace input, number of elbows, length of run and installation (1 or 2 pipes). The optional Combustion Air Pipe is dependent on installation/code requirements and must be 2" or 3" diameter PVC.
- Line voltage wiring can enter through the right or left side of the furnace. Low-voltage wiring can enter through the right or left side of furnace.
- Conversion kits for high-altitude natural gas operation are available. Contact your Goodman distributor or dealer for details.
- Installer must supply following gas line fittings, according to which entrance is used:
Left—Two 90° elbows, one close nipple, straight pipe
Right—Straight pipe to reach gas valve
- For bottom return: Failure to unfold flanges may reduce airflow by up to 18%. This could result in performance and noise issues.

MINIMUM CLEARANCES TO COMBUSTIBLE MATERIALS

POSITION	SIDES	REAR	FRONT	BOTTOM	FLUE	TOP
Upflow	0"	0"	3"	C	0"	1"
Horizontal	6"	0"	3"	C	0"	6"

C = If placed on combustible floor, the floor MUST be wood ONLY.

NOTES:

- For servicing or cleaning, a 24" front clearance is required.
- Unit connections (electrical, flue and drain) may necessitate greater clearances than the minimum clearances listed above.
- In all cases, accessibility clearance must take precedence over clearances from the enclosure where accessibility clearances are greater.

ACVC95 DIMENSIONS

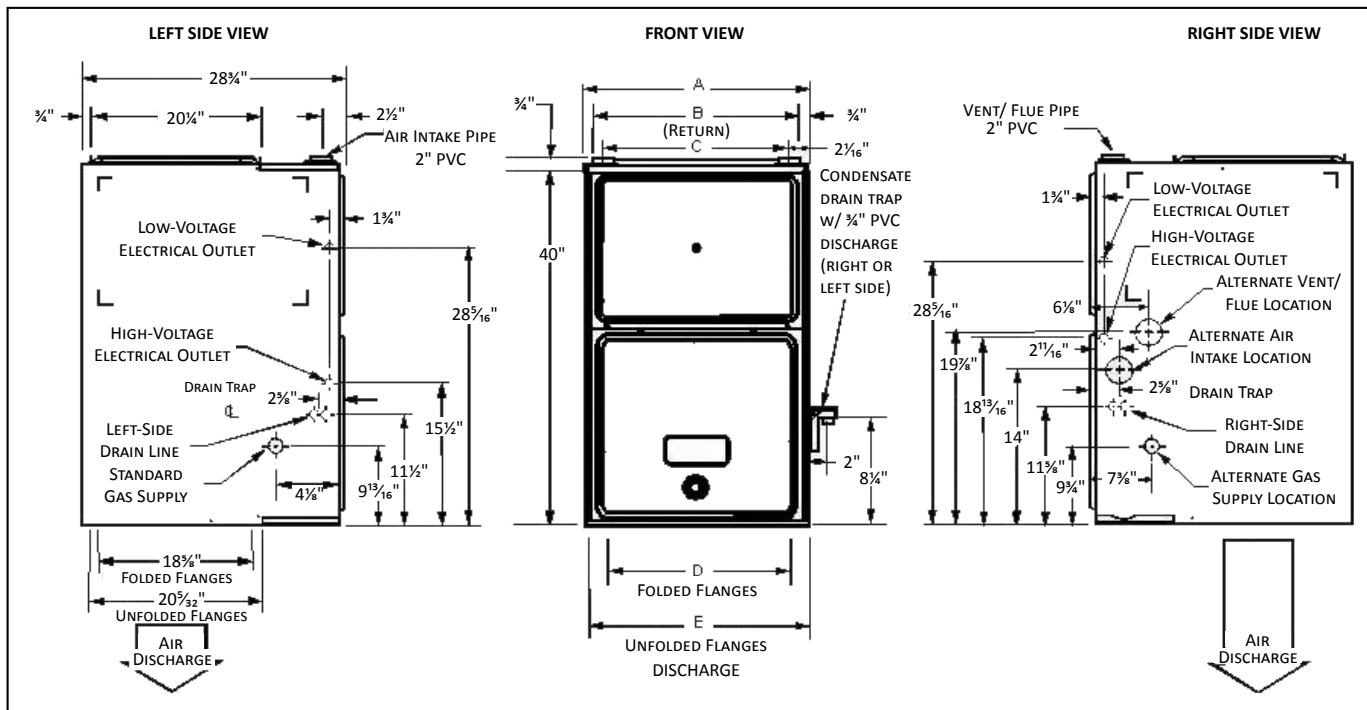

MODEL	A	B	C	D	E
ACVC950714CXB*	21"	19½"	16⅞"	18"	19½"
ACVC950915DXB*	24½"	23"	20⅞"	21½"	23"
ACVC951155DX	24½"	23"	20⅞"	21½"	23"

NOTES:

- Installer must supply one or two PVC pipes: one for combustion air (optional) and one for the flue outlet (required). Vent pipe must be either 2" or 3" in diameter, depending upon furnace input, number of elbows, length of run and installation (1 or 2 pipes). The optional Combustion Air Pipe is dependent on installation/code requirements and must be 2" or 3" diameter PVC.
- Line voltage wiring can enter through the right or left side of the furnace. Low-voltage wiring can enter through the right or left side of furnace.
- Conversion kits for high-altitude natural gas operation are available. Contact your Amana distributor or dealer for details.
- Installer must supply following gas line fittings, according to which entrance is used:
Left—Two 90° Elbows, one close nipple, straight pipe
Right—Straight pipe to reach gas valve

MINIMUM CLEARANCES TO COMBUSTIBLE MATERIALS

POSITION	SIDES	REAR	FRONT	BOTTOM	FLUE	TOP
Downflow	0"	0"	3"	NC	0"	1"
Horizontal	6"	0"	3"	C	0"	6"

C = If placed on combustible floor, the floor **MUST** be wood **ONLY**.

NC = For installation on non-combustible floors only. A combustible floor sub-base must be used for installations on combustible flooring.

NOTES:

- For servicing or cleaning, a 24" front clearance is required.
- Unit connections (electrical, flue and drain) may necessitate greater clearances than the minimum clearances listed above.
- In all cases, accessibility clearance must take precedence over clearances from the enclosure where accessibility clearances are greater.

AMVC95 AIRFLOW DATA

AMVC950453BXA
COOLING SPEED
 (@ .1" - .8" w.c. ESP)

TAP	ADJUST	HIGH-STAGE CFM	LOW-STAGE CFM
A	Minus 10%	540	351
	Minus 5%	570	371
	Normal	600	390
	Plus 5%	630	410
	Plus 10%	660	429
B	Minus 10%	720	468
	Minus 5%	760	494
	Normal	800	520
	Plus 5%	840	546
	Plus 10%	880	572
C	Minus 10%	900	585
	Minus 5%	950	618
	Normal	1,000	650
	Plus 5%	1,050	683
	Plus 10%	1,100	715
D	Minus 10%	1,080	702
	Minus 5%	1,140	741
	Normal	1,200	780
	Plus 5%	1,260	819
	Plus 10%	1,320	858

AMVC950453BXA
HEATING SPEED
 (@ .1" - .5" w.c. ESP; RISE RANGE: 30 - 60°F)

TAP	ADJUST	HIGH-STAGE CFM	LOW-STAGE CFM	RISE (°F)
A	Minus 10%	713	495	57
	Minus 5%	752	523	49
	Normal	792	550	41
	Plus 5%	832	578	43
	Plus 10%	871	605	46
B	Minus 10%	778	540	52
	Minus 5%	821	570	49
	Normal	864	600	47
	Plus 5%	907	630	45
	Plus 10%	950	660	43
C	Minus 10%	842	585	48
	Minus 5%	889	618	45
	Normal	936	650	43
	Plus 5%	983	683	41
	Plus 10%	1,030	715	39
D	Minus 10%	907	630	45
	Minus 5%	958	665	42
	Normal	1,008	700	40
	Plus 5%	1,058	735	38
	Plus 10%	1,109	770	36

AMVC950704CXA
COOLING SPEED
 (@ .1" - .8" w.c. ESP)

TAP	ADJUST	HIGH-STAGE CFM	LOW-STAGE CFM
A	Minus 10%	540	351
	Minus 5%	570	371
	Normal	600	390
	Plus 5%	630	410
	Plus 10%	660	429
B	Minus 10%	720	468
	Minus 5%	760	494
	Normal	800	520
	Plus 5%	840	546
	Plus 10%	880	572
C	Minus 10%	990	644
	Minus 5%	1,045	679
	Normal	1,100	715
	Plus 5%	1,155	751
	Plus 10%	1,210	787
D	Minus 10%	1,286	836
	Minus 5%	1,358	883
	Normal	1,429	929
	Plus 5%	1,500	975
	Plus 10%	1,572	1,022

AMVC950704CXA
HEATING SPEED
 (@ .1" - .5" w.c. ESP; RISE RANGE: 30 - 60°F)

TAP	ADJUST	HIGH-STAGE CFM	LOW-STAGE CFM	RISE (°F)
A	Minus 10%	1,089	756	56
	Minus 5%	1,150	798	53
	Normal	1,210	840	50
	Plus 5%	1,271	882	48
	Plus 10%	1,331	924	46
B	Minus 10%	1,193	828	51
	Minus 5%	1,259	874	48
	Normal	1,325	920	46
	Plus 5%	1,391	966	44
	Plus 10%	1,458	1,012	42
C	Minus 10%	1,296	900	47
	Minus 5%	1,368	950	44
	Normal	1,440	1,000	42
	Plus 5%	1,512	1,050	40
	Plus 10%	1,584	1,100	38
D	Minus 10%	1,400	972	43
	Minus 5%	1,477	1,026	41
	Normal	1,555	1,080	39
	Plus 5%	1,633	1,134	37
	Plus 10%	1,711	1,188	35

NOTES

- All furnaces ship as high speed for cooling. Installer must adjust blower speed as needed.
- For most jobs, about 400 CFM per ton when cooling is desirable.
- Do not operate above .5" w.c. ESP in heating mode. Operating CFM between .5" and .8" w.c. is tabulated for cooling purposes only.

AMVC95 AIRFLOW DATA (CONT.)

AMVC950905CXA
COOLING SPEED
(@ .1" - .8" w.c. ESP)

TAP	ADJUST	HIGH-STAGE CFM	LOW-STAGE CFM
A	Minus 10%	729	495
	Minus 5%	770	523
	Normal	810	550
	Plus 5%	851	578
	Plus 10%	891	605
B	Minus 10%	990	693
	Minus 5%	1,045	732
	Normal	1,100	770
	Plus 5%	1,155	809
	Plus 10%	1,210	847
C	Minus 10%	1,323	900
	Minus 5%	1,397	950
	Normal	1,470	1,000
	Plus 5%	1,544	1,050
	Plus 10%	1,617	1,100
D	Minus 10%	1,629	1,125
	Minus 5%	1,720	1,188
	Normal	1,810	1,250
	Plus 5%	1,901	1,313
	Plus 10%	1,991	1,375

AMVC950905CXA
HEATING SPEED
(@ .1" - .5" w.c. ESP; RISE RANGE: 30 - 60°F)

TAP	ADJUST	HIGH-STAGE CFM	LOW-STAGE CFM	RISE (°F)
A	Minus 10%	1,341	945	60
	Minus 5%	1,416	998	57
	Normal	1,490	1,050	54
	Plus 5%	1,565	1,103	51
	Plus 10%	1,639	1,155	49
B	Minus 10%	1,413	1,008	57
	Minus 5%	1,492	1,064	54
	Normal	1,570	1,120	51
	Plus 5%	1,649	1,176	49
	Plus 10%	1,727	1,232	47
C	Minus 10%	1,521	1,080	53
	Minus 5%	1,606	1,140	50
	Normal	1,690	1,200	48
	Plus 5%	1,775	1,260	45
	Plus 10%	1,859	1,320	43
D	Minus 10%	1,602	1,125	50
	Minus 5%	1,691	1,188	47
	Normal	1,780	1,250	45
	Plus 5%	1,869	1,313	43
	Plus 10%	1,958	1,375	41

AMVC950905DXA
COOLING SPEED
(@ .1" - .8" w.c. ESP)

TAP	ADJUST	HIGH-STAGE CFM	LOW-STAGE CFM
A	Minus 10%	720	468
	Minus 5%	760	494
	Normal	800	520
	Plus 5%	840	546
	Plus 10%	880	572
B	Minus 10%	900	644
	Minus 5%	950	679
	Normal	1,000	715
	Plus 5%	1,050	751
	Plus 10%	1,100	787
C	Minus 10%	1,260	819
	Minus 5%	1,330	865
	Normal	1,400	910
	Plus 5%	1,470	956
	Plus 10%	1,540	1,001
D	Minus 10%	1,620	1,053
	Minus 5%	1,710	1,112
	Normal	1,800	1,170
	Plus 5%	1,890	1,229
	Plus 10%	1,980	1,287

AMVC950905DXA
HEATING SPEED
(@ .1" - .5" w.c. ESP; RISE RANGE: 30 - 60°F)

TAP	ADJUST	HIGH-STAGE CFM	LOW-STAGE CFM	RISE (°F)
A	Minus 10%	1,458	1,013	55
	Minus 5%	1,539	1,069	52
	Normal	1,620	1,125	50
	Plus 5%	1,701	1,181	47
	Plus 10%	1,782	1,238	45
B	Minus 10%	1,549	1,076	52
	Minus 5%	1,635	1,135	49
	Normal	1,721	1,195	47
	Plus 5%	1,807	1,255	45
	Plus 10%	1,893	1,315	43
C	Minus 10%	1,640	1,139	49
	Minus 5%	1,731	1,202	46
	Normal	1,822	1,265	44
	Plus 5%	1,913	1,328	42
	Plus 10%	2,004	1,392	40
D	Minus 10%	1,730	1,202	47
	Minus 5%	1,826	1,268	44
	Normal	1,922	1,335	42
	Plus 5%	2,018	1,402	40
	Plus 10%	2,114	1,469	38

See Notes on previous page.

AMVC95 AIRFLOW DATA (CONT.)

AMVC951155DXA
COOLING SPEED
(@ .1" - .8" w.c. ESP)

TAP	ADJUST	HIGH-STAGE CFM	LOW-STAGE CFM
A	Minus 10%	720	468
	Minus 5%	760	494
	Normal	800	520
	Plus 5%	840	546
	Plus 10%	880	572
B	Minus 10%	990	644
	Minus 5%	1,045	679
	Normal	1,100	715
	Plus 5%	1,155	751
	Plus 10%	1,210	787
C	Minus 10%	1,260	819
	Minus 5%	1,330	865
	Normal	1,400	910
	Plus 5%	1,470	956
	Plus 10%	1,540	1,001
D	Minus 10%	1,620	1,053
	Minus 5%	1,710	1,112
	Normal	1,800	1,170
	Plus 5%	1,890	1,229
	Plus 10%	1,980	1,287

AMVC951155DXA
HEATING SPEED
(@ .1" - .5" w.c. ESP; RISE RANGE: 35 - 65°F)

TAP	ADJUST	HIGH-STAGE CFM	LOW-STAGE CFM	RISE (°F)
A	Minus 10%	1,594	1,107	63
	Minus 5%	1,682	1,169	60
	Normal	1,771	1,230	57
	Plus 5%	1,860	1,292	54
	Plus 10%	1,948	1,353	52
B	Minus 10%	1,640	1,139	62
	Minus 5%	1,731	1,202	59
	Normal	1,822	1,265	56
	Plus 5%	1,913	1,328	53
	Plus 10%	2,004	1,392	50
C	Minus 10%	1,685	1,170	60
	Minus 5%	1,778	1,235	57
	Normal	1,872	1,300	54
	Plus 5%	1,966	1,365	51
	Plus 10%	2,059	1,430	49
D	Minus 10%	1,730	1,202	58
	Minus 5%	1,826	1,268	55
	Normal	1,922	1,335	53
	Plus 5%	2,018	1,402	50
	Plus 10%	2,114	1,469	48

NOTES

- All furnaces ship as high speed for cooling. Installer must adjust blower speed as needed.
- For most jobs, about 400 CFM per ton when cooling is desirable.
- Do not operate above .5" w.c. ESP in heating mode. Operating CFM between .5" and .8" w.c. is tabulated for cooling purposes only.

ACVC95 AIRFLOW DATA

ACVC950714CXA
COOLING SPEEDS
(@ .1" - .8" w.c. ESP)

TAP	ADJUST	HIGH-STAGE CFM	LOW-STAGE CFM
A	Minus 10%	594	324
	Minus 5%	627	342
	Normal	660	360
	Plus 5%	693	378
	Plus 10%	726	396
B	Minus 10%	747	468
	Minus 5%	789	494
	Normal	830	520
	Plus 5%	872	546
	Plus 10%	913	572
C	Minus 10%	1,017	702
	Minus 5%	1,074	741
	Normal	1,130	780
	Plus 5%	1,187	819
	Plus 10%	1,243	858
D	Minus 10%	1,314	864
	Minus 5%	1,387	912
	Normal	1,460	960
	Plus 5%	1,533	1,008
	Plus 10%	1,606	1,056

ACVC950714CXA
HEATING SPEED
(@ .1" - .5" w.c. ESP; RISE RANGE: 25 - 55°F)

TAP	ADJUST	HIGH-STAGE CFM	LOW-STAGE CFM	RISE (°F)
A	Minus 10%	1,107	783	77
	Minus 5%	1,169	827	73
	Normal	1,230	870	69
	Plus 5%	1,292	914	66
	Plus 10%	1,353	957	63
B	Minus 10%	1,215	855	71
	Minus 5%	1,283	903	68
	Normal	1,350	950	64
	Plus 5%	1,418	998	61
	Plus 10%	1,485	1,045	58
C	Minus 10%	1,323	936	65
	Minus 5%	1,397	988	61
	Normal	1,470	1,040	58
	Plus 5%	1,544	1,092	55
	Plus 10%	1,617	1,144	53
D	Minus 10%	1,440	1,017	59
	Minus 5%	1,520	1,074	56
	Normal	1,600	1,130	53
	Plus 5%	1,680	1,187	51
	Plus 10%	1,760	1,243	49

ACVC95 AIRFLOW DATA (CONT.)

ACVC950915DXA
COOLING SPEEDS
(@ .1" - .8" w.c. ESP)

TAP	ADJUST	HIGH-STAGE CFM	LOW-STAGE CFM
A	Minus 10%	729	504
	Minus 5%	770	532
	Normal	810	560
	Plus 5%	851	588
	Plus 10%	891	616
B	Minus 10%	999	666
	Minus 5%	1,055	703
	Normal	1,110	740
	Plus 5%	1,166	777
	Plus 10%	1,221	814
C	Minus 10%	1,287	828
	Minus 5%	1,359	874
	Normal	1,430	920
	Plus 5%	1,502	966
	Plus 10%	1,573	1,012
D	Minus 10%	1,674	1,071
	Minus 5%	1,767	1,131
	Normal	1,860	1,190
	Plus 5%	1,953	1,250
	Plus 10%	2,046	1,309

ACVC950915DXA
HEATING SPEED
(@ .1" - .5" w.c. ESP; RISE RANGE: 25 - 55°F)

TAP	ADJUST	HIGH-STAGE CFM	LOW-STAGE CFM	RISE
A	Minus 10%	1,458	1,008	80
	Minus 5%	1,539	1,064	76
	Normal	1,620	1,120	72
	Plus 5%	1,701	1,176	68
	Plus 10%	1,782	1,232	65
B	Minus 10%	1,575	1,098	73
	Minus 5%	1,663	1,159	69
	Normal	1,750	1,220	66
	Plus 5%	1,838	1,281	63
	Plus 10%	1,925	1,342	60
C	Minus 10%	1,674	1,152	70
	Minus 5%	1,767	1,216	66
	Normal	1,860	1,280	63
	Plus 5%	1,953	1,344	60
	Plus 10%	2,046	1,408	57
D	Minus 10%	1,773	1,206	67
	Minus 5%	1,872	1,273	63
	Normal	1,970	1,340	60
	Plus 5%	2,069	1,407	57
	Plus 10%	2,167	1,474	55

ACVC951155DX
COOLING SPEEDS
(@ .1" - .8" w.c. ESP)

TAP	ADJUST	HIGH-STAGE CFM	LOW-STAGE CFM
A	Minus 10%	705	457
	Minus 5%	744	483
	Normal	783	508
	Plus 5%	822	533
	Plus 10%	861	559
B	Minus 10%	982	621
	Minus 5%	1,036	656
	Normal	1,091	690
	Plus 5%	1,146	725
	Plus 10%	1,200	759
C	Minus 10%	1,265	815
	Minus 5%	1,336	861
	Normal	1,406	906
	Plus 5%	1,476	951
	Plus 10%	1,547	997
D	Minus 10%	1,628	1,049
	Minus 5%	1,719	1,107
	Normal	1,809	1,165
	Plus 5%	1,899	1,223
	Plus 10%	1,990	1,282

ACVC951155DX
HEATING SPEED
(@ .1" - .5" w.c. ESP; RISE RANGE: 40 - 70°F)

TAP	ADJUST	HIGH-STAGE CFM	LOW-STAGE CFM	RISE
A	Minus 10%	1,583	1,093	63
	Minus 5%	1,671	1,153	59
	Normal	1,759	1,214	56
	Plus 5%	1,847	1,275	53
	Plus 10%	1,935	1,335	51
B	Minus 10%	1,612	1,106	61
	Minus 5%	1,701	1,168	58
	Normal	1,791	1,229	55
	Plus 5%	1,881	1,290	52
	Plus 10%	1,970	1,352	50
C	Minus 10%	1,654	1,166	60
	Minus 5%	1,746	1,231	57
	Normal	1,838	1,296	54
	Plus 5%	1,930	1,361	51
	Plus 10%	2,022	1,426	49
D	Minus 10%	1,690	1,172	59
	Minus 5%	1,784	1,237	56
	Normal	1,878	1,302	53
	Plus 5%	1,972	1,367	50
	Plus 10%	2,066	1,432	48

NOTES

- All furnaces ship as high speed for cooling. Installer must adjust blower speed as needed.
- For most jobs, about 400 CFM per ton when cooling is desirable.
- Do not operate above .5" w.c. ESP in heating mode. Operating CFM between .5" and .8" w.c. is tabulated for cooling purposes only.

TEMPERATURE RISE RANGE CHART

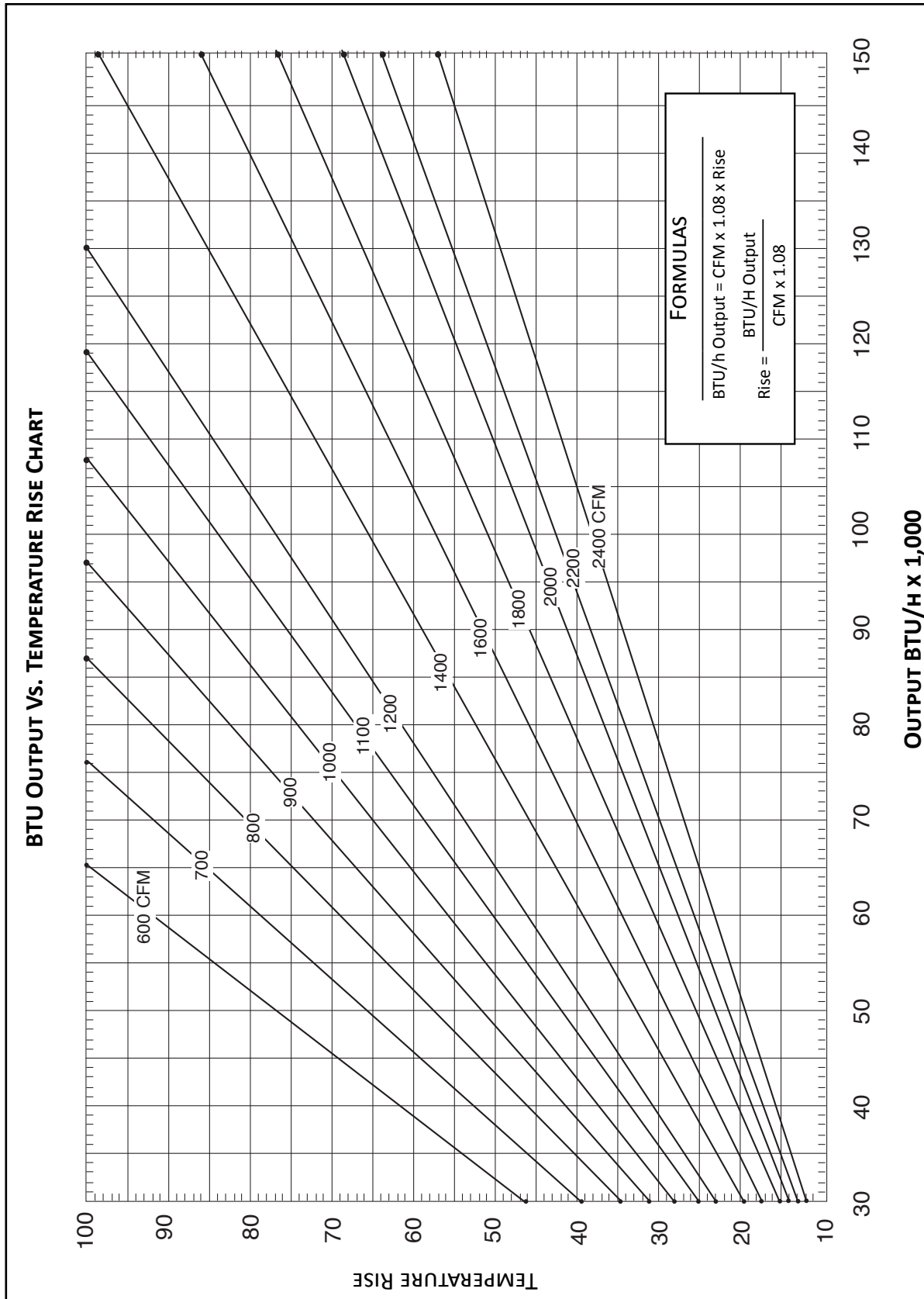

WIRING DIAGRAM

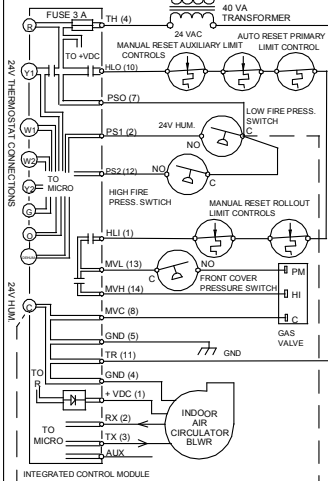
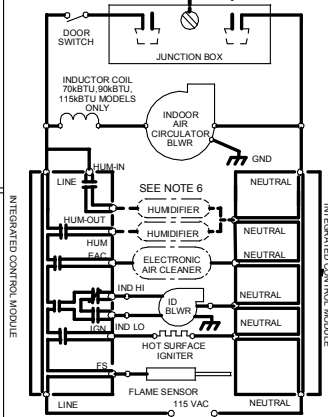
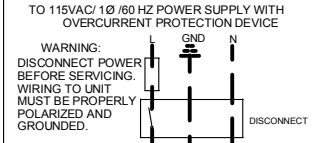
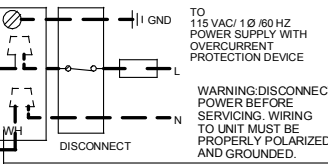
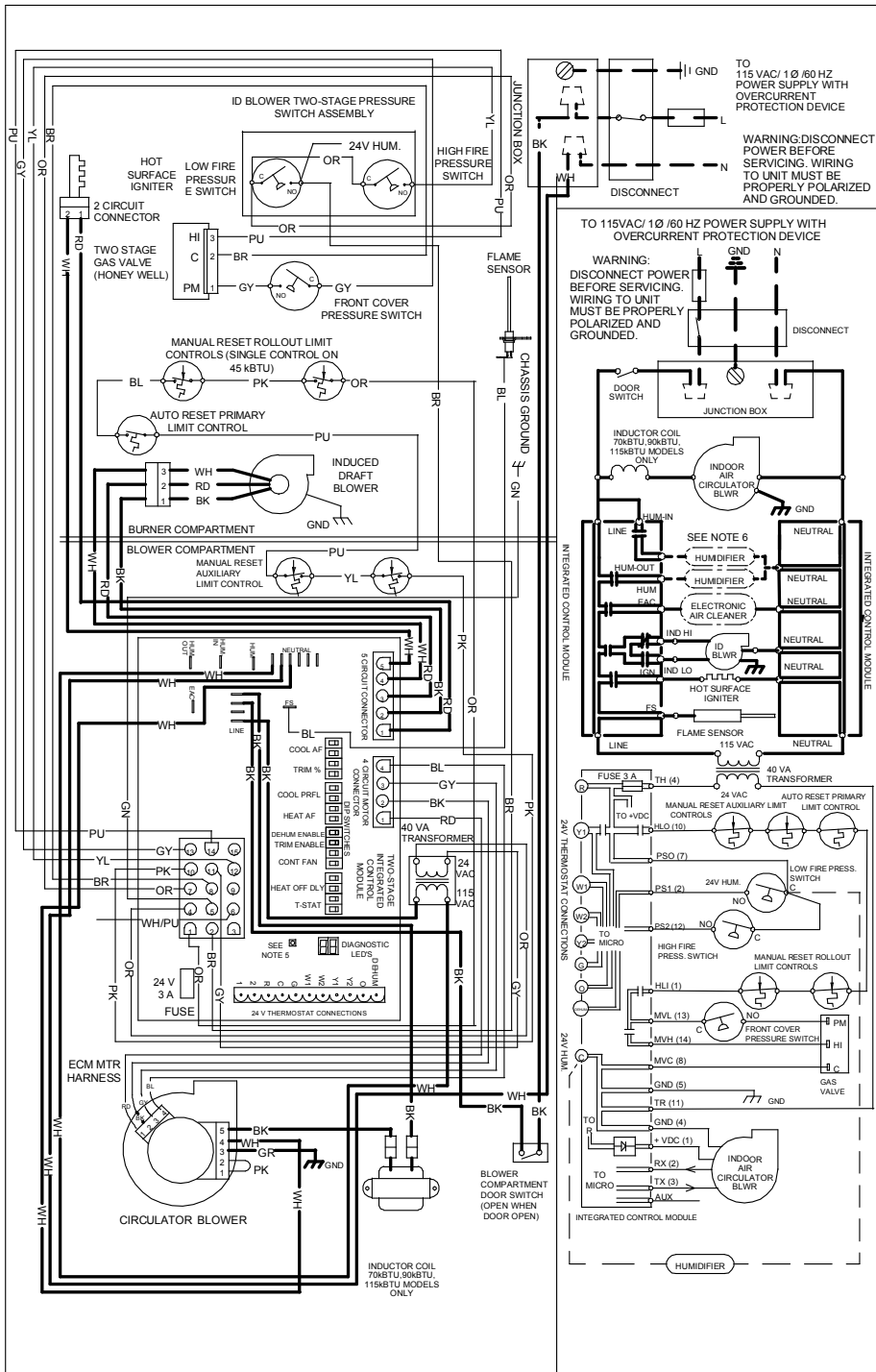

High Voltage: Disconnect all power before servicing or installing this unit. Multiple power sources may be present. Failure to do so may cause property damage, personal injury, or death.

WARNING

Wiring is subject to change. Always refer to the wiring diagram or the unit for the most up-to-date wiring.

NOTES:

1. SET HEAT ANTICIPATOR ON ROOM THERMOSTAT AT 0.7 AMPS.
2. MANUFACTURER'S SPECIFIED REPLACEMENT PARTS MUST BE USED WHEN SERVICING.
3. IF ANY OF THE ORIGINAL WIRE AS SUPPLIED WITH THE FURNACE MUST BE REPLACED, IT MUST BE REPLACED WITH WIRING MATERIAL HAVING A TEMPERATURE RATING OF AT LEAST 105°C. USE COPPER CONDUCTORS ONLY.
4. UNIT MUST BE PERMANENTLY GROUNDED AND CONFORM TO N.E.C. AND LOCAL CODES.
5. TO RECALL THE LAST 6 FAULTS, MOST RECENT TO LEAST RECENT, DEPRESS SWITCH FOR MORE THAN 2 SECONDS WHILE IN STANDBY (NO THERMOSTAT INPUTS).
6. HUMIDIFIER INSTALLATION OPTIONS: USE HUM TERMINAL TO RUN HUMIDIFIER DURING HEAT CALL (COMMUNICATING OR LEGACY MODES). USE HUM-IN AND HUM-OUT TERMINALS TO RUN HUMIDIFIER DURING HEAT CALL (COMMUNICATING MODE OR LEGACY MODE) OR INDEPENDENTLY FROM HEAT CALL (COMMUNICATING MODE ONLY - SETUP IS DONE WITHIN COMMUNICATING THERMOSTAT).

COLOR CODES:

- PK PINK
- BR BROWN
- WH WHITE
- BL BLUE
- GY GRAY
- RD RED
- YL YELLOW
- OR ORANGE
- PU PURPLE
- GN GREEN
- BK BLACK

- LOW VOLTAGE (24V) ———
- LOW VOLTAGE FIELD ———
- HI VOLTAGE (115V) ———
- HI VOLTAGE FIELD ———
- JUNCTION ———
- TERMINAL ———
- INTERNAL ———
- INTEGRATED CONTROL ———
- PLUG CONNECTION ———

- EQUIPMENT GND ———
- FIELD GND ———
- FIELD SPLICE ———
- SWITCH (TEMP.) ———
- IGNITER ———
- SWITCH (PRESS.) ———
- OVERCURRENT PROT. DEVICE ———

0140F01201-B



ACCESSORIES

MODEL	DESCRIPTION	AMVC95 0453BXA	AMVC95 0704CXA	AMVC95 0905*XA	AMVC95 1155DXA	ACVC95 0714CXA	ACVC95 0915DXA	ACVC95 1155DX
LPM-06	LP Conversion Kit (springs & orifice)	1	1	1	1	1	1	1
ASAS	Electronic Air Cleaners (-10, -11, -12 or -18)	√	√	√	√	√	√	√
AMU	Media Air Cleaners (1620, 2020, 1625 or 2025)	√	√	√	√	√	√	√
DEHUM1	Dehumidistat	√	√	√	√	√	√	√
HAPS28	High-Altitude Pressure Switch Kit	2	2	---	---	---	---	---
HAPS29	High-Altitude Pressure Switch Kit	---	---	2	2	---	---	---
HAPS 31	High-Altitude Pressure Switch Kit	---	---	---	---	2	2	2
HALP11	High-Altitude Propane Gas Kit	2	2	2	2	---	---	---
HALP 13	High-Altitude Propane Gas Kit	---	---	---	---	2	2	2
HANG 13	High-Altitude Natural Gas Kit	3	3	3	3	---	---	---
HANG 14	High-Altitude Natural Gas Kit	4	4	4	4	---	---	---
HANG 16	High-Altitude Natural Gas Kit	---	---	---	---	2	2	2
EFR01	External Filter Rack	√	√	√	√	√	√	√
DCVK-20	Horizontal/Vertical Concentric Vent Kit (2")	√	√	√	---	√	---	---
DCVK-30	Horizontal/Vertical Concentric Vent Kit (3")	√	√	√	√	√	√	√
CFB21	Downflow Floor Base	---	---	---	---	√	---	---
CFB24	Downflow Floor Base	---	---	---	---	---	√	√
017K0000S	Flush-mount vent kit	√	√	√	√	√	√	√

NOTES

- √ Indicates available for this model
- 1 Indicates 7,001' to 9,000' altitude
- 2 Indicates 9,001' to 11,000' altitude
- 3 Indicates 7,001' to 11,000' altitude
- All installations above 7,000' require a pressure switch change.
- For installation in Canada, gas furnaces are certified only to 4,500'.

THERMOSTATS



CTK03 ComfortNet-compatible Control
(See ComfortNet website (www.comfortnet1.com) for details.)



CTK02 ComfortNet-compatible Control
(See ComfortNet website (www.comfortnet1.com) for details.)



CTK01 ComfortNet-compatible Control
(See ComfortNet website (www.comfortnet1.com) for details.)