

**HIGH-EFFICIENCY
 R-32 SPLIT SYSTEM HEAT PUMP
 UP TO 16 SEER2 & 8.2 HSPF2
 1½ TO 5 TONS**



Contents

Nomenclature..... 2
 Product Specifications..... 3
 Expanded Cooling Data 4
 Expanded Heating Data..... 18
 Performance Data 20
 Dimensions 21
 Wiring Diagrams 22
 Accessories 24

R32

Standard Features

- High-Efficiency Copeland® scroll compressor
- Advanced Copeland® CoreSense technology
- Enhanced aluminum fin with coil-5mm diameter copper tubes in 1.5T-3.5 ton
- Enhanced aluminum fin coil with 7mm diameter copper tubes 4.0-5.0 ton
- Single-speed PSC condenser fan motor
- SmartShift® technology to ensure quiet reliable defrost
- High density foam compressor sound blanket
- Factory-installed bi-flow liquid-line filter drier
- Factory-installed suction-line accumulator
- Factory-installed compressor crankcase heater
- Factory-installed high-capacity muffler
- High and low-pressure switches
- Service valves with sweat connections and easy access to gauge ports
- Copper tube / enhanced aluminum fin coil
- Fully enclosed contactor
- Capacitor with extended life
- AHRI Certified; ETL Listed

Cabinet Features

- Removable grille-style top design compliant with UL 60335-2-40
- Heavy-gauge galvanized-steel cabinet
- Baked-on powder-paint finish with 500-hour salt-spray approval
- Steel louver coil guard with rust-resistant screws
- Top and side maintenance access
- Single-panel access to controls with space provided for field-installed for field-installed accessories
- When properly anchored, it meets the 2023 Florida Building Code unit integrity requirements for hurricane-type winds (Anchor bracket kits available.)



Proper sizing and installation of equipment is critical to achieve optimal performance. Split system air conditioners and heat pumps must be matched with appropriate coil components to meet **ENERGY STAR®** criteria. Ask your contractor for details or visit www.energystar.gov.







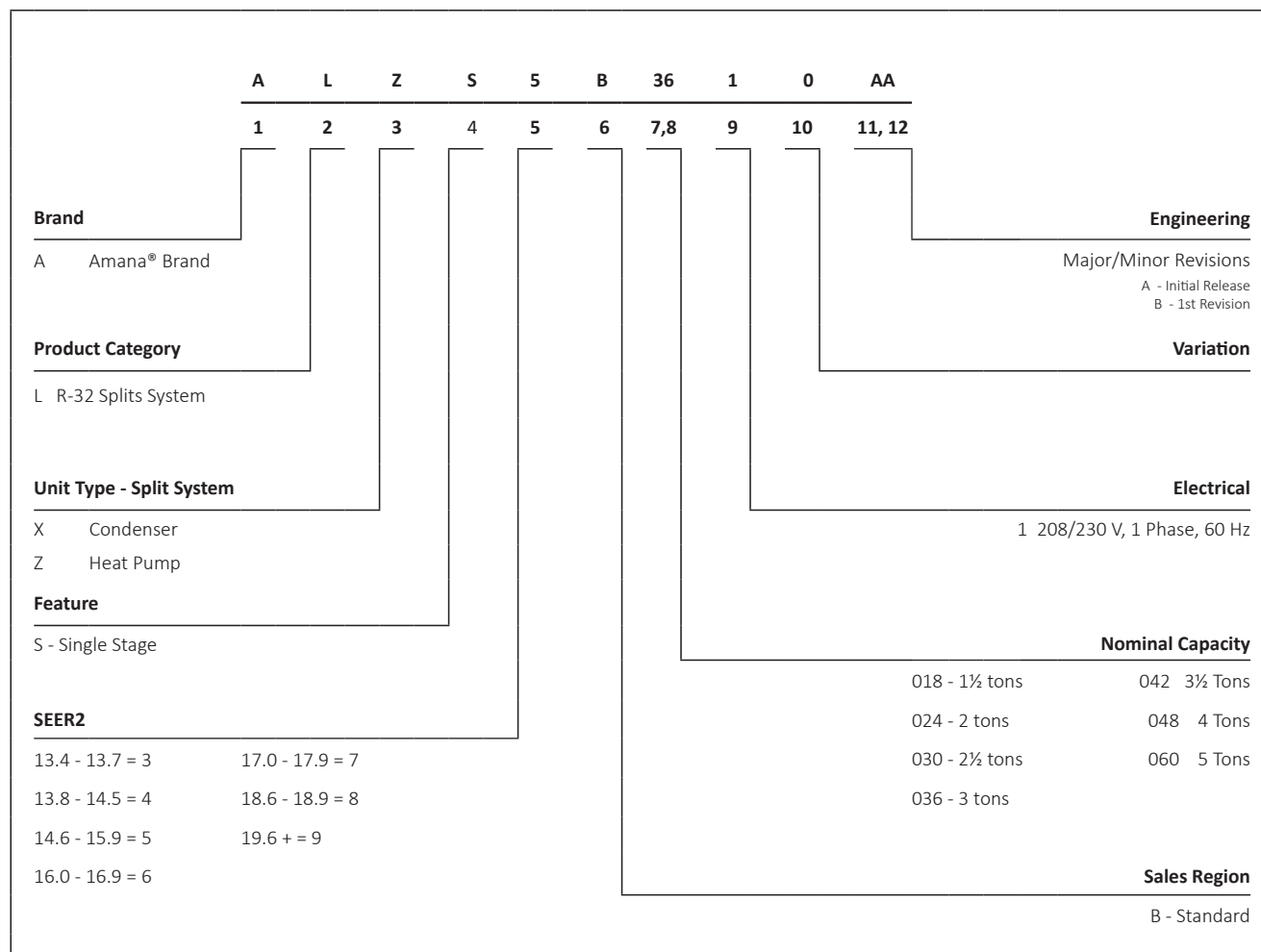

COMPANY WITH QUALITY SYSTEM CERTIFIED BY DNV GL
 = ISO 9001 =

COMPANY WITH ENVIRONMENTAL SYSTEM CERTIFIED BY DNV GL
 = ISO 14001 =

* Complete warranty details available from your local dealer or at www.amana-hac.com To receive the Lifetime Unit Replacement Limited Warranty (good for as long as you own your home) and 10-Year Parts Limited Warranty, online registration must be completed within 60 days of installation. Online registration is not required in California or Québec. The duration of warranty coverage in Texas and Florida differs in some cases.



	ALZS5BA 1810A*	ALZS5BA 2410A*	ALZS5BA 3010A*	ALZS5BA 3610A*	ALZS5BA 4210A*	ALZS5BA 4810A*	ALZS5BA 6010A*
NOMINAL CAPACITIES							
Cooling (BTU/h)	18,000	24,000	30,000	36,000	42,000	48,000	60,000
Heating (BTU/h)	18,000	24,000	30,000	36,000	42,000	48,000	60,000
SEER2	15.2	15.2	15.2	15.2	15.2	15.2	15.2
Decibels	70.0	73.0	73.0	71.1	72.0	73.6	74.8
COMPRESSOR							
RLA	8.3	10.2	12.8	16.4	14.4	19.4	27.1
LRA	44.3	59.3	76.0	88.0	112.2	127.7	178.0
Stage	Single	Single	Single	Single	Single	Single	Two
Type	Scroll	Scroll	Scroll	Scroll	Scroll	Scroll	Scroll
CONDENSER FAN MOTOR							
Horsepower	1/6	1/6	1/6	1/6	1/4	1/4	1/5
FLA	0.95	0.95	0.97	1.0	1.3	1.3	1.0
REFRIGERATION SYSTEM							
Refrigerant Line Size ¹							
Liquid Line Size ("O.D.)	3/8"	3/8"	3/8"	3/8"	3/8"	3/8"	3/8"
Suction Line Size ("O.D.)	3/4"	3/4"	3/4"	7/8"	1 1/8"	1 1/8"	1 1/8"
Refrigerant Connection Size							
Liquid Valve Size ("O.D.)	3/8"	3/8"	3/8"	3/8"	3/8"	3/8"	3/8"
Suction Valve Size ("O.D.)	3/4"	3/4"	3/4"	7/8"	7/8"	7/8"	7/8"
Valve Connection Type	Sweat	Sweat	Sweat	Sweat	Sweat	Sweat	Sweat
Refrigerant Charge (oz.)	88	83	94	95	139	174	185
ELECTRICAL DATA							
Volts/Phase (60 Hz)	208/230	208/230	208/230	208/230	208/230	208/230	208/230
Minimum Circuit Ampacity ²	11.4	13.8	17.0	21.5	19.3	25.5	34.8
Max. Overcurrent Protection ³	15	20	25	35	30	40	60
Min / Max Volts	197/253	197/253	197/253	197/253	197/253	197/253	197/253
Electrical Conduit Size	1/2" or 3/4"	1/2" or 3/4"	1/2" or 3/4"	1/2" or 3/4"	1/2" or 3/4"	1/2" or 3/4"	1/2" or 3/4"
UNIT WEIGHTS							
Equipment Weight	171	186	215	222	257	264	309
Shipping Weight	186	213	235	242	277	284	329
ENERGY STAR® CERTIFIED							
							

¹ Tested and rated in accordance with AHRI Standard 210/240

² Wire size should be determined in accordance with National Electrical Codes; extensive wire runs will require larger wire sizes

³ Must use time-delay fuses or HACR-type circuit breakers of the same size as noted.

NOTES

- Always check the S&R plate for electrical data on the unit being installed.
- Installer will need to supply 3/8" to 1 1/4" adapters for suction line connections.
- Unit is charged with refrigerant for 15' of 3/8" liquid line. System charge must be adjusted per Installation Instructions Final Charge Procedure.
- Installation of these units requires the specified TXV Kit to be installed on the indoor coil.
THE SPECIFIED TXV IS DETERMINED BY THE OUTDOOR UNIT NOT THE INDOOR COIL.

ENERGY STAR NOTES

Proper sizing and installation of equipment is critical to achieving optimal performance. Split system air conditioners and heat pumps must be matched with appropriate coil components to meet ENERGY STAR criteria. Ask your contractor for details or visit www.energystar.gov. The www.energystar.gov website provides up-to-date system combinations certified to meet ENERGY STAR requirements.

COOLING DATA — ALZ55BA1810A*+AMST24BU1300A*

IDB		OUTDOOR AMBIENT TEMPERATURE																																															
		65°F						75°F						85°F						95°F						105°F						115°F																	
		59	63	67	71	71	59	63	67	71	71	59	63	67	71	71	59	63	67	71	71	59	63	67	71	71	59	63	67	71	71																		
525	MBh	18.2	18.4	19.0	-	18.0	18.3	18.8	-	17.5	17.8	18.3	-	16.7	17.0	17.5	-	15.7	16.0	16.5	-	14.8	15.1	15.6	-	18.2	18.4	19.0	-	18.0	18.3	18.8	-	17.5	17.8	18.3	-	16.7	17.0	17.5	-	15.7	16.0	16.5	-	14.8	15.1	15.6	-
	S/T	0.56	0.48	0.34	-	0.57	0.49	0.35	-	0.59	0.51	0.38	-	0.61	0.53	0.40	-	0.63	0.56	0.42	-	0.69	0.61	0.47	-	0.56	0.48	0.34	-	0.57	0.49	0.35	-	0.59	0.51	0.38	-	0.61	0.53	0.40	-	0.63	0.56	0.42	-	0.69	0.61	0.47	-
	ΔT	19	18	14	-	19	17	14	-	19	18	15	-	19	17	14	-	19	17	14	-	20	18	15	-	19	18	14	-	19	17	14	-	19	18	15	-	19	17	14	-	20	18	15	-	20	18	15	-
	kW	1.05	1.05	1.05	-	1.17	1.17	1.16	-	1.30	1.30	1.30	-	1.44	1.44	1.44	-	1.60	1.60	1.60	-	1.79	1.79	1.79	-	1.05	1.05	1.05	-	1.17	1.17	1.16	-	1.30	1.30	1.30	-	1.44	1.44	1.44	-	1.60	1.60	1.60	-	1.79	1.79	1.79	-
	Amps	4.0	4.0	4.0	-	4.6	4.6	4.6	-	5.2	5.2	5.2	-	5.8	5.8	5.8	-	6.6	6.6	6.6	-	7.4	7.4	7.4	-	4.0	4.0	4.0	-	4.6	4.6	4.6	-	5.2	5.2	5.2	-	5.8	5.8	5.8	-	6.6	6.6	6.6	-	7.4	7.4	7.4	-
70	MBh	18.4	18.6	19.2	-	18.2	18.5	19.0	-	17.7	18.0	18.5	-	16.9	17.2	17.7	-	15.9	16.2	16.7	-	15.0	15.2	15.8	-	18.4	18.6	19.2	-	18.2	18.5	19.0	-	17.7	18.0	18.5	-	16.9	17.2	17.7	-	15.9	16.2	16.7	-	15.0	15.2	15.8	-
	S/T	0.63	0.56	0.42	-	0.64	0.56	0.43	-	0.67	0.59	0.45	-	0.69	0.61	0.47	-	0.71	0.63	0.49	-	0.76	0.68	0.55	-	0.63	0.56	0.42	-	0.64	0.56	0.43	-	0.67	0.59	0.45	-	0.69	0.61	0.47	-	0.71	0.63	0.49	-	0.76	0.68	0.55	-
	ΔT	18	16	13	-	18	16	13	-	18	17	13	-	18	16	13	-	18	16	13	-	19	17	14	-	18	16	13	-	18	16	13	-	18	17	13	-	18	16	13	-	18	16	13	-	19	17	14	-
	kW	1.06	1.05	1.05	-	1.17	1.17	1.17	-	1.31	1.31	1.30	-	1.45	1.45	1.45	-	1.61	1.61	1.61	-	1.80	1.80	1.79	-	1.06	1.05	1.05	-	1.17	1.17	1.17	-	1.31	1.31	1.30	-	1.45	1.45	1.45	-	1.61	1.61	1.61	-	1.80	1.80	1.79	-
	Amps	4.1	4.1	4.1	-	4.6	4.6	4.6	-	5.2	5.2	5.2	-	5.9	5.9	5.9	-	6.6	6.6	6.6	-	7.5	7.5	7.4	-	4.1	4.1	4.1	-	4.6	4.6	4.6	-	5.2	5.2	5.2	-	5.9	5.9	5.9	-	6.6	6.6	6.6	-	7.5	7.5	7.4	-
660	MBh	18.6	18.8	19.4	-	18.4	18.6	19.2	-	17.9	18.2	18.7	-	17.1	17.3	17.9	-	16.1	16.3	16.9	-	15.2	15.4	16.0	-	18.6	18.8	19.4	-	18.4	18.6	19.2	-	17.9	18.2	18.7	-	17.1	17.3	17.9	-	16.1	16.3	16.9	-	15.2	15.4	16.0	-
	S/T	0.68	0.60	0.46	-	0.68	0.60	0.47	-	0.71	0.63	0.49	-	0.73	0.65	0.51	-	0.75	0.67	0.53	-	0.80	0.72	0.59	-	0.68	0.60	0.46	-	0.68	0.60	0.47	-	0.71	0.63	0.49	-	0.73	0.65	0.51	-	0.75	0.67	0.53	-	0.80	0.72	0.59	-
	ΔT	17	16	13	-	17	16	12	-	17	16	13	-	17	16	12	-	17	15	12	-	18	16	13	-	17	16	13	-	17	16	12	-	17	16	13	-	17	16	12	-	17	15	12	-	18	16	13	-
	kW	1.06	1.06	1.06	-	1.18	1.18	1.18	-	1.31	1.31	1.31	-	1.45	1.45	1.45	-	1.61	1.61	1.61	-	1.80	1.80	1.80	-	1.06	1.06	1.06	-	1.18	1.18	1.18	-	1.31	1.31	1.31	-	1.45	1.45	1.45	-	1.61	1.61	1.61	-	1.80	1.80	1.80	-
	Amps	4.1	4.1	4.1	-	4.6	4.6	4.6	-	5.2	5.2	5.2	-	5.9	5.9	5.9	-	6.6	6.6	6.6	-	7.5	7.5	7.4	-	4.1	4.1	4.1	-	4.6	4.6	4.6	-	5.2	5.2	5.2	-	5.9	5.9	5.9	-	6.6	6.6	6.6	-	7.5	7.5	7.4	-

525	MBh	18.2	18.4	19.0	19.8	18.0	18.3	18.8	19.7	17.5	17.8	18.4	19.2	16.7	17.0	17.5	18.4	15.7	16.0	16.5	17.4	14.8	15.1	15.6	16.4	18.2	18.4	19.0	19.8	18.0	18.3	18.8	19.7	17.5	17.8	18.4	19.2	16.7	17.0	17.5	18.4	15.7	16.0	16.5	17.4	14.8	15.1	15.6	16.4
	S/T	0.69	0.61	0.48	0.33	0.70	0.62	0.48	0.34	0.72	0.64	0.51	0.36	0.74	0.66	0.53	0.38	0.76	0.69	0.55	0.40	0.82	0.74	0.60	0.46	0.69	0.61	0.48	0.33	0.70	0.62	0.48	0.34	0.72	0.64	0.51	0.36	0.74	0.66	0.53	0.38	0.76	0.69	0.55	0.40	0.82	0.74	0.60	0.46
	ΔT	23	21	18	15	23	21	18	15	23	21	18	15	23	21	18	15	23	21	18	14	24	22	19	16	23	21	18	15	23	21	18	15	23	21	18	15	23	21	18	15	23	21	18	14	24	22	19	16
	kW	1.05	1.05	1.04	1.1	1.17	1.17	1.16	1.2	1.30	1.30	1.30	1.3	1.44	1.44	1.44	1.4	1.60	1.60	1.60	1.6	1.79	1.79	1.79	1.8	1.05	1.05	1.04	1.1	1.17	1.17	1.16	1.2	1.30	1.30	1.30	1.3	1.44	1.44	1.44	1.4	1.60	1.60	1.60	1.6	1.79	1.79	1.79	1.8
	Amps	4.0	4.0	4.0	4.1	4.6	4.6	4.6	4.6	5.2	5.2	5.2	5.2	5.8	5.8	5.8	5.9	6.6	6.6	6.6	6.6	7.4	7.4	7.4	7.5	4.0	4.0	4.0	4.1	4.6	4.6	4.6	4.6	5.2	5.2	5.2	5.2	5.8	5.8	5.8	5.9	6.6	6.6	6.6	6.6	7.4	7.4	7.4	7.5
600	MBh	18.4	18.6	19.2	20.0	18.2	18.5	19.0	19.9	17.7	18.0	18.5	19.4	16.9	17.2	17.7	18.6	15.9	16.2	16.7	17.6	15.0	15.3	15.8	16.6	18.4	18.6	19.2	20.0	18.2	18.5	19.0	19.9	17.7	18.0	18.5	19.4	16.9	17.2	17.7	18.6	15.9	16.2	16.7	17.6	15.0	15.3	15.8	16.6
	S/T	0.76	0.69	0.55	0.41	0.77	0.69	0.56	0.41	0.80	0.72	0.58	0.44	0.82	0.74	0.60	0.46	0.84	0.76	0.62	0.48	0.89	0.81	0.68	0.53	0.76	0.69	0.55	0.41	0.77	0.69	0.56	0.41	0.80	0.72	0.58	0.44	0.82	0.74	0.60	0.46	0.84	0.76	0.62	0.48	0.89	0.81	0.68	0.53
	ΔT	22	20	17	14	22	20	17	14	22	20	17	14	22	20	17	14	22	20	17	13	23	21	18	14	22	20	17	14	22	20	17	14	22	20	17	14	22	20	17	13	23	21	18	14	24	22	19	16
	kW	1.05	1.05	1.05	1.06	1.17	1.17	1.17	1.18	1.31	1.31	1.30	1.31	1.45	1.45	1.45	1.45	1.61	1.61	1.61	1.61	1.80	1.80	1.80	1.80	1.05	1.05	1.05	1.06	1.17	1.17	1.17	1.18	1.31	1.30	1.30	1.31	1.45	1.45	1.45	1.45	1.61	1.61	1.61	1.61	1.80	1.80	1.80	1.80
	Amps	4.1	4.1	4.0	4.1	4.6	4.6	4.6	4.6	5.2	5.2	5.2	5.2	5.9	5.9	5.9	5.9	6.6	6.6	6.6	6.6	7.5	7.5	7.4	7.5	4.1	4.1	4.0	4.1	4.6	4.6	4.6	4.6	5.2	5.2	5.2	5.2	5.9	5.9	5.9	5.9	6.6	6.6	6.6	6.6	7.5	7.5	7.4	7.5
660	MBh	18.6	18.8	19.4	20.2	18.4	18.7	19.2	20.0	17.9	18.2	18.7	19.6	17.1	17.4	17.9	18.7	16.1	16.4	16.9	17.7	15.2	15.4	16.0	16.8	18.6	18.8	19.4	20.2	18.4	18.7	19.2	20.0	17.9	18.2	18.7	19.6	17.1	17.4	17.9	18.7	16.1	16.4	16.9	17.7	15.2	15.4	16.0	16.8
	S/T	0.81	0.73	0.59	0.45	0.81	0.74	0.60	0.45	0.84	0.76	0.62	0.48	0.86	0.78	0.64	0.50	0.88	0.80	0.67	0.52	0.93	0.86	0.72	0.57	0.81	0.73	0.59	0.45	0.81	0.74	0.60	0.45	0.84	0.76	0.62	0.48	0.86	0.78	0.64	0.50	0.88	0.80	0.67	0.52	0.93	0.86	0.72	0.57
	ΔT	21	19	16	13	21	19	16	13	21	20	16	13	21	19	16	13	21	19	16	13	22	20	17	14	21	19	16	13	21	19	16	13	21	20	16	13	21	19	16	13	21	19	16	13	22	20	17	14
	kW	1.06	1.06	1.06	1.1	1.18	1.18	1.17	1.2	1.31	1.31	1.31	1.3	1.45	1.45	1.45	1.5	1.61	1.61	1.61	1.6	1.80	1.80	1.80	1.8	1.06	1.06	1.06	1.1	1.18	1.18	1.17	1.2	1.31	1.31	1.31	1.3	1.45	1.45	1.45	1.5	1.61	1.61	1.61	1.6	1.80	1.80	1.80	1.8
	Amps	4.1	4.1	4.1	4.1	4.6	4.6	4.6	4.7	5.2	5.2	5.2	5.3	5.9	5.9	5.9	5.9	6.6	6.6	6.6	6.6	7.5	7.5	7.5	7.5	4.1	4.1	4.1	4.1	4.6																			

COOLING DATA — ALZ5BA1810A*+AMST24BU1300A* (CONT.)

IDB	AIRFLOW	OUTDOOR AMBIENT TEMPERATURE																							
		65°F				75°F				85°F				95°F				105°F				115°F			
		59	63	67	71	59	63	67	71	59	63	67	71	59	63	67	71	59	63	67	71	59	63	67	71
80	MBh	18.3	18.5	19.1	19.9	18.1	18.4	18.9	19.8	17.6	17.9	18.4	19.3	16.8	17.1	17.6	18.5	15.8	16.1	16.6	17.5	14.9	15.2	15.7	16.5
	S/T	0.82	0.74	0.60	0.46	0.82	0.75	0.61	0.46	0.85	0.77	0.63	0.49	0.87	0.79	0.65	0.51	0.89	0.81	0.68	0.53	0.94	0.87	0.73	0.58
	ΔT	27	25	22	19	27	25	22	18	27	25	22	19	27	25	22	18	26	25	22	18	27	26	23	19
	kW	1.05	1.05	1.05	1.1	1.17	1.17	1.16	1.2	1.30	1.30	1.30	1.3	1.44	1.44	1.44	1.4	1.60	1.60	1.60	1.6	1.79	1.79	1.79	1.8
	Amps	4.0	4.0	4.0	4.1	4.6	4.6	4.6	4.6	5.2	5.2	5.2	5.2	5.8	5.8	5.8	5.9	6.6	6.6	6.6	6.6	7.4	7.4	7.4	7.5
600	MBh	18.5	18.7	19.3	20.1	18.3	18.6	19.1	20.0	17.8	18.1	18.6	19.5	17.0	17.3	17.8	18.7	16.0	16.3	16.8	17.7	15.1	15.4	15.9	16.7
	S/T	0.89	0.81	0.68	0.53	0.90	0.82	0.68	0.54	0.92	0.85	0.71	0.56	0.94	0.87	0.73	0.58	0.97	0.89	0.75	0.61	1.00	0.94	0.80	0.66
	ΔT	26	24	21	17	26	24	21	17	26	24	21	18	26	24	21	17	25	24	20	17	26	25	22	18
	kW	1.05	1.05	1.05	1.06	1.17	1.17	1.17	1.18	1.31	1.31	1.30	1.31	1.45	1.45	1.45	1.46	1.61	1.61	1.61	1.62	1.80	1.80	1.80	1.80
	Amps	4.1	4.1	4.1	4.1	4.6	4.6	4.6	4.6	5.2	5.2	5.2	5.2	5.9	5.9	5.9	5.9	6.6	6.6	6.6	6.6	7.5	7.5	7.5	7.5
660	MBh	18.7	18.9	19.5	20.3	18.5	18.8	19.3	20.1	18.0	18.3	18.8	19.7	17.2	17.5	18.0	18.8	16.2	16.4	17.0	17.8	15.3	15.5	16.1	16.9
	S/T	0.93	0.86	0.72	0.57	0.94	0.86	0.73	0.58	0.97	0.89	0.75	0.61	0.98	0.91	0.77	0.63	1.00	0.93	0.79	0.65	1.00	0.98	0.84	0.70
	ΔT	25	23	20	17	25	23	20	17	25	23	20	17	25	23	20	17	25	23	20	16	26	24	21	18
	kW	1.06	1.06	1.06	1.1	1.18	1.18	1.17	1.2	1.31	1.31	1.31	1.3	1.45	1.45	1.45	1.5	1.61	1.61	1.61	1.6	1.80	1.80	1.80	1.8
	Amps	4.1	4.1	4.1	4.1	4.6	4.6	4.6	4.7	5.2	5.2	5.2	5.3	5.9	5.9	5.9	5.9	6.6	6.6	6.6	6.6	7.5	7.5	7.5	7.5

85	MBh	18.6	18.9	19.4	20.2	18.4	18.7	19.2	20.1	18.0	18.2	18.8	19.6	17.1	17.4	17.9	18.8	16.1	16.4	16.9	17.8	15.2	15.5	16.0	16.8
	S/T	0.92	0.84	0.71	0.56	0.93	0.85	0.71	0.57	0.95	0.87	0.74	0.59	0.97	0.89	0.76	0.61	0.99	0.92	0.78	0.63	1.00	0.97	0.83	0.69
	ΔT	30	28	25	22	30	28	25	22	30	29	25	22	30	28	25	22	30	28	25	22	31	29	26	23
	kW	1.05	1.05	1.05	1.1	1.17	1.17	1.17	1.2	1.30	1.30	1.30	1.3	1.45	1.44	1.44	1.5	1.61	1.60	1.60	1.6	1.79	1.79	1.79	1.8
	Amps	4.0	4.0	4.0	4.1	4.6	4.6	4.6	4.6	5.2	5.2	5.2	5.2	5.8	5.8	5.8	5.9	6.6	6.6	6.6	6.6	7.4	7.4	7.4	7.5
600	MBh	18.8	19.0	19.6	20.4	18.6	18.9	19.4	20.3	18.1	18.4	19.0	19.8	17.3	17.6	18.1	19.0	16.3	16.6	17.1	18.0	15.4	15.7	16.2	17.0
	S/T	0.99	0.92	0.78	0.64	1.00	0.92	0.79	0.64	1.00	0.95	0.81	0.67	1.00	0.97	0.83	0.69	1.00	0.99	0.85	0.71	1.00	1.00	0.91	0.76
	ΔT	29	27	24	21	29	27	24	21	29	27	24	21	29	27	24	21	29	27	24	21	30	28	25	22
	kW	1.06	1.06	1.05	1.06	1.18	1.17	1.17	1.18	1.31	1.31	1.31	1.31	1.45	1.45	1.45	1.46	1.61	1.61	1.61	1.62	1.80	1.80	1.80	1.81
	Amps	4.1	4.1	4.1	4.1	4.6	4.6	4.6	4.6	5.2	5.2	5.2	5.3	5.9	5.9	5.9	5.9	6.6	6.6	6.6	6.6	7.5	7.5	7.5	7.5
660	MBh	19.0	19.2	19.8	20.6	18.8	19.1	19.6	20.4	18.3	18.6	19.1	20.0	17.5	17.8	18.3	19.1	16.5	16.8	17.3	18.1	15.6	15.8	16.4	17.2
	S/T	1.00	0.96	0.82	0.68	1.00	0.97	0.83	0.68	1.00	0.99	0.85	0.71	1.00	1.00	0.87	0.73	1.00	1.00	0.90	0.75	1.00	1.00	0.95	0.80
	ΔT	28	27	23	20	28	27	23	20	28	27	24	20	28	26	23	20	28	26	23	20	29	27	24	21
	kW	1.06	1.06	1.06	1.1	1.18	1.18	1.18	1.2	1.31	1.31	1.31	1.3	1.46	1.46	1.45	1.5	1.62	1.62	1.61	1.6	1.80	1.80	1.80	1.8
	Amps	4.1	4.1	4.1	4.1	4.6	4.6	4.6	4.7	5.2	5.2	5.2	5.3	5.9	5.9	5.9	5.9	6.6	6.6	6.6	6.7	7.5	7.5	7.5	7.5

IDB: Entering Indoor Dry Bulb Temperature
 High and low pressures are measured at the liquid and suction service valves.
 Shaded area reflects AHRI Rating Conditions.
 kW = Total system power
 Amps = Outdoor unit amps (compressor + fan)

COOLING DATA — ALZ55BA2410A*+AMST24BU1300A*

IDB		OUTDOOR AMBIENT TEMPERATURE												105°F												115°F																							
		65°F						75°F						85°F						95°F						105°F						115°F																	
		59	63	67	71	59	63	67	71	59	63	67	71	59	63	67	71	59	63	67	71	59	63	67	71	59	63	67	71																				
700	AIRFLOW	23.7	24.0	24.7	-	23.5	23.8	24.5	-	22.9	23.2	23.9	-	21.8	22.1	22.8	-	20.5	20.8	21.5	-	19.3	19.6	20.4	-	23.7	24.0	24.7	-	23.5	23.8	24.5	-	22.9	23.2	23.9	-	21.8	22.1	22.8	-	20.5	20.8	21.5	-	19.3	19.6	20.4	-
	MBh	0.62	0.54	0.41	-	0.62	0.55	0.41	-	0.65	0.57	0.44	-	1.00	0.59	0.46	-	1.00	0.61	0.48	-	1.00	0.67	0.53	-	0.62	0.54	0.41	-	0.62	0.55	0.41	-	0.65	0.57	0.44	-	1.00	0.59	0.46	-	1.00	0.61	0.48	-	1.00	0.67	0.53	-
	S/T	19	17	14	-	19	17	14	-	20	18	14	-	19	17	14	-	19	17	14	-	20	18	15	-	19	17	14	-	19	17	14	-	20	18	14	-	19	17	14	-	20	18	15	-	20	18	15	-
	ΔT	1.34	1.34	1.33	-	1.50	1.50	1.49	-	1.68	1.67	1.67	-	1.87	1.87	1.86	-	2.08	2.08	2.08	-	2.34	2.34	2.33	-	1.34	1.34	1.33	-	1.50	1.50	1.49	-	1.68	1.67	1.67	-	1.87	1.87	1.86	-	2.08	2.08	2.08	-	2.34	2.34	2.33	-
	kW	5.2	5.2	5.2	-	5.9	5.9	5.9	-	6.8	6.7	6.7	-	7.6	7.6	7.6	-	8.6	8.6	8.6	-	9.8	9.8	9.8	-	5.2	5.2	5.2	-	5.9	5.9	5.9	-	6.8	6.7	6.7	-	7.6	7.6	7.6	-	8.6	8.6	8.6	-	9.8	9.8	9.8	-
Amps	23.9	24.2	25.0	-	23.7	24.0	24.7	-	23.1	23.4	24.1	-	22.0	22.4	23.1	-	20.7	21.1	21.8	-	19.5	19.9	20.6	-	23.9	24.2	25.0	-	23.7	24.0	24.7	-	23.1	23.4	24.1	-	22.0	22.4	23.1	-	20.7	21.1	21.8	-	19.5	19.9	20.6	-	
770	MBh	0.66	0.58	0.45	-	0.66	0.59	0.45	-	0.69	0.61	0.48	-	1.00	0.63	0.50	-	1.00	0.65	0.52	-	1.00	0.71	0.57	-	0.66	0.58	0.45	-	0.66	0.59	0.45	-	0.69	0.61	0.48	-	1.00	0.63	0.50	-	1.00	0.65	0.52	-	1.00	0.71	0.57	-
	S/T	19	17	13	-	18	17	13	-	19	17	14	-	18	17	13	-	18	16	13	-	19	18	14	-	19	17	13	-	18	17	13	-	19	17	14	-	18	16	13	-	19	18	14	-	19	18	14	-
	ΔT	1.34	1.34	1.34	-	1.50	1.50	1.50	-	1.68	1.68	1.68	-	1.87	1.87	1.87	-	2.09	2.09	2.09	-	2.34	2.34	2.34	-	1.34	1.34	1.34	-	1.50	1.50	1.50	-	1.68	1.68	1.68	-	1.87	1.87	1.87	-	2.09	2.09	2.09	-	2.34	2.34	2.34	-
	kW	5.2	5.2	5.2	-	6.0	6.0	5.9	-	6.8	6.8	6.8	-	7.7	7.7	7.6	-	8.7	8.6	8.6	-	9.8	9.8	9.8	-	5.2	5.2	5.2	-	6.0	6.0	5.9	-	6.8	6.8	6.8	-	7.7	7.7	7.6	-	8.7	8.6	8.6	-	9.8	9.8	9.8	-
	Amps	24.4	24.8	25.5	-	24.2	24.6	25.3	-	23.6	23.9	24.6	-	22.5	22.9	23.6	-	21.2	21.6	22.3	-	20.1	20.4	21.1	-	24.4	24.8	25.5	-	24.2	24.6	25.3	-	23.6	23.9	24.6	-	22.5	22.9	23.6	-	21.2	21.6	22.3	-	20.1	20.4	21.1	-
900	MBh	0.70	0.62	0.49	-	0.70	0.63	0.49	-	1.00	0.65	0.52	-	1.00	0.67	0.54	-	1.00	0.69	0.56	-	1.00	1.00	0.61	-	0.70	0.62	0.49	-	0.70	0.63	0.49	-	1.00	0.65	0.52	-	1.00	0.67	0.54	-	1.00	0.69	0.56	-	1.00	1.00	0.61	-
	S/T	17	16	12	-	17	15	12	-	18	16	12	-	17	15	12	-	17	15	12	-	18	16	13	-	17	16	12	-	17	15	12	-	18	16	12	-	17	15	12	-	18	16	13	-	18	16	13	-
	ΔT	1.35	1.35	1.35	-	1.51	1.51	1.51	-	1.69	1.69	1.69	-	1.88	1.88	1.88	-	2.10	2.10	2.10	-	2.35	2.35	2.35	-	1.35	1.35	1.35	-	1.51	1.51	1.51	-	1.69	1.69	1.69	-	1.88	1.88	1.88	-	2.10	2.10	2.10	-	2.35	2.35	2.35	-
	kW	5.3	5.3	5.3	-	6.0	6.0	6.0	-	6.8	6.8	6.8	-	7.7	7.7	7.7	-	8.7	8.7	8.7	-	9.9	9.8	9.8	-	5.3	5.3	5.3	-	6.0	6.0	6.0	-	6.8	6.8	6.8	-	7.7	7.7	7.7	-	8.7	8.7	8.7	-	9.9	9.8	9.8	-
	Amps	24.4	24.8	25.5	-	24.2	24.6	25.3	-	23.6	23.9	24.6	-	22.5	22.9	23.6	-	21.2	21.6	22.3	-	20.1	20.4	21.1	-	24.4	24.8	25.5	-	24.2	24.6	25.3	-	23.6	23.9	24.6	-	22.5	22.9	23.6	-	21.2	21.6	22.3	-	20.1	20.4	21.1	-

700	MBh	23.7	24.0	24.7	25.8	23.5	23.8	24.5	25.6	22.9	23.2	23.9	25.0	21.8	22.1	22.8	23.9	20.5	20.8	21.6	22.6	19.3	19.7	20.4	21.4	23.7	24.0	24.7	25.8	23.5	23.8	24.5	25.6	22.9	23.2	23.9	25.0	21.8	22.1	22.8	23.9	20.5	20.8	21.6	22.6	19.3	19.7	20.4	21.4
	S/T	0.75	0.67	0.54	0.39	1.00	0.68	0.54	0.40	1.00	0.70	0.57	0.43	1.00	0.72	0.59	0.44	1.00	0.74	0.61	0.47	1.00	1.00	0.66	0.52	0.75	0.67	0.54	0.39	1.00	0.68	0.54	0.40	1.00	0.70	0.57	0.43	1.00	0.72	0.59	0.44	1.00	0.74	0.61	0.47	1.00	1.00	0.66	0.52
	ΔT	23	21	18	15	23	21	18	15	24	22	18	15	23	21	18	15	23	21	18	14	24	22	19	15	23	21	18	15	23	21	18	15	24	22	18	15	23	21	18	15	24	22	19	15	24	22	19	15
	kW	1.34	1.34	1.33	1.3	1.50	1.49	1.49	1.5	1.67	1.67	1.67	1.7	1.87	1.87	1.86	1.9	2.08	2.08	2.08	2.1	2.34	2.34	2.33	2.3	1.34	1.34	1.33	1.3	1.50	1.49	1.49	1.5	1.67	1.67	1.67	1.7	1.87	1.87	1.86	1.9	2.08	2.08	2.08	2.1	2.34	2.34	2.33	2.3
	Amps	5.2	5.2	5.2	5.2	5.9	5.9	5.9	6.0	6.7	6.7	6.7	6.8	7.6	7.6	7.6	7.7	8.6	8.6	8.6	8.7	9.8	9.8	9.8	9.8	5.2	5.2	5.2	5.2	5.9	5.9	5.9	6.0	6.7	6.7	6.7	6.8	7.6	7.6	7.6	7.7	8.6	8.6	8.6	8.7	9.8	9.8	9.8	9.8
770	MBh	0.79	0.71	0.58	0.44	1.00	0.72	0.58	0.44	1.00	0.74	0.61	0.47	1.00	0.76	0.63	0.49	1.00	0.78	0.65	0.51	1.00	1.00	0.70	0.56	0.79	0.71	0.58	0.44	1.00	0.72	0.58	0.44	1.00	0.74	0.61	0.47	1.00	0.76	0.63	0.49	1.00	0.78	0.65	0.51	1.00	1.00	0.70	0.56
	S/T	23	21	17	14	22	21	17	14	23	21	18	14	22	21	17	14	22	20	17	14	23	22	18	15	23	21	17	14	22	21	17	14	23	21	18	14	22	20	17	14	23	22	18	15	23	22	18	15
	ΔT	1.34	1.34	1.34	1.35	1.50	1.50	1.50	1.51	1.68	1.68	1.68	1.69	1.87	1.87	1.87	1.88	2.09	2.09	2.09	2.10	2.34	2.34	2.34	2.35	1.34	1.34	1.34	1.35	1.50	1.50	1.50	1.51	1.68	1.68	1.68	1.69	1.87	1.87	1.87	1.88	2.09	2.09	2.09	2.10	2.34	2.34	2.34	2.35
	kW	5.2	5.2	5.2	5.3	6.0	6.0	5.9	6.0	6.8	6.8	6.8	6.8	7.7	7.7	7.7	7.7	8.6	8.6	8.6	8.7	9.8	9.8	9.8	9.8	5.2	5.2	5.2	5.3	6.0	6.0	5.9	6.0	6.8	6.8	6.8	6.8	7.7	7.7	7.7	7.7	8.6	8.6	8.6	8.7	9.8	9.8	9.8	9.8
	Amps	24.4	24.8	25.5	26.6	24.2	24.6	25.3	26.4	23.6	24.0	24.7	25.7	22.6	22.9	23.6	24.7	21.3	21.6	22.3	23.4	20.1	20.4	21.1	22.2	24.4	24.8	25.5	26.6	24.2	24.6	25.3	26.4	23.6	24.0	24.7	25.7	22.6	22.9	23.6	24.7	21.3	21.6	22.3	23.4	20.1	20.4	21.1	22.2
900	MBh	0.83	0.75	0.62	0.47	1.00	0.76	0.62	0.48	1.00	0.78	0.65	0.51	1.00	0.80	0.67	0.52	1.00	0.82	0.69	0.55	1.00	1.00	0.74	0.60	0.83	0.75	0.62	0.47	1.00	0.76	0.62	0.48	1.00	0.78	0.65	0.51	1.00	0.80	0.67	0.52	1.00	0.82	0.69	0.55	1.00	1.00	0.74	0.60
	S/T	21	19	16	13	21	19	16	13	22	20	16	13	21	19	16	13	21	19	16	12	22	20	17	13	21	19	16	13	21	19	16	13	22	20	16	13	21	19	16	12	22	20	17	13	22	20	17	13
	ΔT	1.35	1.35	1.35	1.4	1.51	1.51	1.51	1.5	1.69	1.69	1.69	1.7	1.88	1.88	1.88	1.9	2.10	2.10	2.10	2.1	2.35	2.35	2.35	2.4	1.35	1.35	1.35	1.4	1.51	1.51	1.51	1.5	1.69	1.69	1.69	1.7	1.88	1.88	1.88	1.9	2.10	2.10	2.10	2.1	2.35	2.35	2.35	2.4
	kW	5.3	5.3	5.2	5.3	6.0	6.0	6.0	6.0	6.8	6.8	6.8	6.9	7.7	7.7	7.7	7.7	8.7	8.7	8.7	8.7	9.8	9.8	9.8	9.9	5.3	5.3	5.2	5.3	6.0	6.0	6.0	6.0	6.8	6.8	6.8	6.												

COOLING DATA — ALZ55BA2410A*+AMST24BU1300A* (CONT.)

IDB	AIRFLOW	OUTDOOR AMBIENT TEMPERATURE																							
		65°F				75°F				85°F				95°F				105°F				115°F			
		59	63	67	71	59	63	67	71	59	63	67	71	59	63	67	71	59	63	67	71	59	63	67	71
80	MBh	23.8	24.2	24.9	25.9	23.6	23.9	24.6	25.7	23.0	23.3	24.0	25.1	21.9	22.3	23.0	24.0	20.6	21.0	21.7	22.8	19.5	19.8	20.5	21.6
	S/T	1.00	0.79	0.66	0.52	1.00	0.80	0.67	0.52	1.00	0.82	0.69	0.55	1.00	1.00	0.71	0.57	1.00	1.00	0.73	0.59	1.00	1.00	0.78	0.64
	ΔT	27	26	22	19	27	25	22	19	28	26	22	19	27	25	22	19	27	25	22	18	28	26	23	19
	kW	1.34	1.34	1.33	1.3	1.50	1.50	1.49	1.5	1.68	1.67	1.67	1.7	1.87	1.87	1.86	1.9	2.08	2.08	2.08	2.1	2.34	2.34	2.34	2.3
	Amps	5.2	5.2	5.2	5.2	5.9	5.9	5.9	6.0	6.8	6.7	6.7	6.8	7.6	7.6	7.6	7.7	8.6	8.6	8.6	8.7	9.8	9.8	9.8	9.8
700	MBh	24.0	24.4	25.1	26.2	23.8	24.2	24.9	26.0	23.2	23.6	24.3	25.3	22.2	22.5	23.2	24.3	20.9	21.2	21.9	23.0	19.7	20.0	20.7	21.8
	S/T	1.00	0.83	0.70	0.56	1.00	0.84	0.71	0.57	1.00	0.86	0.73	0.59	1.00	1.00	0.75	0.61	1.00	1.00	0.77	0.63	1.00	1.00	0.82	0.68
	ΔT	27	25	21	18	27	25	21	18	27	25	22	18	26	25	21	18	26	24	21	18	27	26	22	19
	kW	1.34	1.34	1.34	1.35	1.50	1.50	1.50	1.51	1.68	1.68	1.68	1.69	1.87	1.87	1.87	1.88	2.09	2.09	2.09	2.10	2.34	2.34	2.34	2.35
	Amps	5.2	5.2	5.2	5.3	6.0	6.0	6.0	6.0	6.8	6.8	6.8	6.8	7.7	7.7	7.6	7.7	8.6	8.6	8.6	8.7	9.8	9.8	9.8	9.8
900	MBh	24.6	24.9	25.6	26.7	24.4	24.7	25.4	26.5	23.7	24.1	24.8	25.9	22.7	23.0	23.7	24.8	21.4	21.7	22.4	23.5	20.2	20.5	21.2	22.3
	S/T	1.00	0.87	0.74	0.60	1.00	0.88	0.75	0.60	1.00	1.00	0.77	0.63	1.00	1.00	0.79	0.65	1.00	1.00	0.81	0.67	1.00	1.00	1.00	0.72
	ΔT	25	24	20	17	25	23	20	17	26	24	20	17	25	23	20	17	25	23	20	16	26	24	21	17
	kW	1.35	1.35	1.35	1.4	1.51	1.51	1.51	1.5	1.69	1.69	1.69	1.7	1.88	1.88	1.88	1.9	2.10	2.10	2.10	2.1	2.35	2.35	2.35	2.4
	Amps	5.3	5.3	5.3	5.3	6.0	6.0	6.0	6.0	6.8	6.8	6.8	6.9	7.7	7.7	7.7	7.7	8.7	8.7	8.7	8.7	9.9	9.9	9.8	9.9

700	MBh	24.2	24.5	25.3	26.3	24.0	24.3	25.0	26.1	23.4	23.7	24.4	25.5	22.3	22.7	23.4	24.4	21.0	21.4	22.1	23.1	19.8	20.2	20.9	22.0
	S/T	1.00	0.89	0.76	0.62	1.00	1.00	0.77	0.62	1.00	1.00	0.79	0.65	1.00	1.00	0.81	0.67	1.00	1.00	1.00	0.69	1.00	1.00	1.00	0.74
	ΔT	31	29	26	22	31	29	26	22	31	29	26	22	31	29	26	22	31	29	25	22	32	30	27	23
	kW	1.34	1.34	1.34	1.3	1.50	1.50	1.50	1.5	1.68	1.68	1.67	1.7	1.87	1.87	1.87	1.9	2.09	2.09	2.08	2.1	2.34	2.34	2.34	2.3
	Amps	5.2	5.2	5.2	5.3	5.9	5.9	5.9	6.0	6.8	6.8	6.7	6.8	7.6	7.6	7.6	7.7	8.6	8.6	8.6	8.7	9.8	9.8	9.8	9.8
770	MBh	24.4	24.8	25.5	26.6	24.2	24.6	25.3	26.4	23.6	24.0	24.7	25.7	22.6	22.9	23.6	24.7	21.3	21.6	22.3	23.4	20.1	20.4	21.1	22.2
	S/T	1.00	0.93	0.80	0.66	1.00	1.00	0.81	0.67	1.00	1.00	0.83	0.69	1.00	1.00	0.85	0.71	1.00	1.00	1.00	0.73	1.00	1.00	1.00	0.78
	ΔT	30	28	25	21	30	28	25	21	30	29	25	22	30	28	25	21	30	28	25	21	31	29	26	22
	kW	1.35	1.34	1.34	1.35	1.51	1.50	1.50	1.51	1.68	1.68	1.68	1.69	1.88	1.88	1.87	1.89	2.09	2.09	2.09	2.10	2.35	2.35	2.34	2.35
	Amps	5.2	5.2	5.2	5.3	6.0	6.0	6.0	6.0	6.8	6.8	6.8	6.8	7.7	7.7	7.7	7.7	8.7	8.7	8.6	8.7	9.8	9.8	9.8	9.9
900	MBh	25.0	25.3	26.0	27.1	24.8	25.1	25.8	26.9	24.1	24.5	25.2	26.3	23.1	23.4	24.1	25.2	21.8	22.1	22.8	23.9	20.6	20.9	21.6	22.7
	S/T	1.00	0.97	0.84	0.70	1.00	1.00	0.85	0.70	1.00	1.00	0.87	0.73	1.00	1.00	0.89	0.75	1.00	1.00	1.00	0.77	1.00	1.00	1.00	0.82
	ΔT	29	27	24	20	29	27	24	20	29	27	24	20	29	27	24	20	29	27	23	20	30	28	25	21
	kW	1.36	1.35	1.35	1.4	1.52	1.51	1.51	1.5	1.69	1.69	1.69	1.7	1.89	1.89	1.88	1.9	2.10	2.10	2.10	2.1	2.36	2.35	2.35	2.4
	Amps	5.3	5.3	5.3	5.3	6.0	6.0	6.0	6.1	6.8	6.8	6.8	6.9	7.7	7.7	7.7	7.8	8.7	8.7	8.7	8.7	9.9	9.9	9.8	9.9

IDB: Entering Indoor Dry Bulb Temperature
 High and low pressures are measured at the liquid and suction service valves.
 Shaded area reflects AHRI Rating Conditions.
 kW = Total system power
 Amps = Outdoor unit amps (compressor + fan)

IDB	AIRFLOW	OUTDOOR AMBIENT TEMPERATURE																							
		65°F				75°F				85°F				95°F				105°F				115°F			
		59	63	67	71	59	63	67	71	59	63	67	71	59	63	67	71	59	63	67	71	59	63	67	71
70	MBh	29.0	29.4	30.2	-	28.7	29.1	30.0	-	27.9	28.4	29.2	-	26.6	27.0	27.9	-	25.0	25.4	26.3	-	23.6	24.0	24.9	-
	S/T	0.59	0.51	0.37	-	0.60	0.52	0.38	-	0.62	0.54	0.40	-	1.00	0.56	0.42	-	1.00	0.59	0.45	-	1.00	0.64	0.50	-
	ΔT	20	18	15	-	20	18	15	-	20	18	15	-	20	18	15	-	20	18	14	-	21	19	16	-
	kW	1.67	1.67	1.66	-	1.86	1.85	1.85	-	2.07	2.07	2.06	-	2.30	2.29	2.29	-	2.55	2.55	2.55	-	2.85	2.85	2.85	-
	Amps	6.1	6.1	6.1	-	7.0	7.0	6.9	-	7.9	7.9	7.9	-	9.0	9.0	9.0	-	10.2	10.1	10.1	-	11.5	11.5	11.5	-
1060	MBh	29.5	29.9	30.8	-	29.2	29.6	30.5	-	28.5	28.9	29.7	-	27.2	27.6	28.4	-	25.6	26.0	26.8	-	24.1	24.5	25.4	-
	S/T	0.68	0.61	0.47	-	0.69	0.61	0.47	-	0.72	0.64	0.50	-	1.00	0.66	0.52	-	1.00	0.68	0.54	-	1.00	0.73	0.59	-
	ΔT	18	16	13	-	18	16	13	-	18	17	13	-	18	16	13	-	18	16	13	-	19	17	14	-
	kW	1.68	1.68	1.68	-	1.87	1.87	1.87	-	2.08	2.08	2.08	-	2.31	2.31	2.31	-	2.57	2.56	2.56	-	2.86	2.86	2.86	-
	Amps	6.2	6.2	6.1	-	7.0	7.0	7.0	-	8.0	8.0	8.0	-	9.0	9.0	9.0	-	10.2	10.2	10.2	-	11.6	11.6	11.6	-
1125	MBh	29.7	30.1	31.0	-	29.4	29.8	30.7	-	28.7	29.1	30.0	-	27.4	27.8	28.6	-	25.8	26.2	27.0	-	24.3	24.7	25.6	-
	S/T	0.70	0.63	0.49	-	0.71	0.63	0.49	-	0.74	0.66	0.52	-	1.00	0.68	0.54	-	1.00	0.70	0.56	-	1.00	0.75	0.61	-
	ΔT	18	16	13	-	18	16	13	-	18	16	13	-	18	16	13	-	17	16	12	-	19	17	13	-
	kW	1.69	1.68	1.68	-	1.87	1.87	1.87	-	2.09	2.08	2.08	-	2.31	2.31	2.31	-	2.57	2.57	2.56	-	2.87	2.87	2.86	-
	Amps	6.2	6.2	6.2	-	7.1	7.0	7.0	-	8.0	8.0	8.0	-	9.1	9.1	9.0	-	10.2	10.2	10.2	-	11.6	11.6	11.6	-

75	MBh	29.0	29.4	30.3	31.6	28.7	29.1	30.0	31.3	28.0	28.4	29.2	30.6	26.7	27.1	27.9	29.3	25.1	25.5	26.3	27.7	23.6	24.0	24.9	26.2
	S/T	0.72	0.64	0.50	0.36	0.73	0.65	0.51	0.36	1.00	0.68	0.54	0.39	1.00	0.70	0.56	0.41	1.00	0.72	0.58	0.43	1.00	1.00	0.63	0.49
	ΔT	24	22	19	15	24	22	19	15	24	22	19	15	24	22	19	15	23	22	18	15	25	23	19	16
	kW	1.67	1.66	1.66	1.7	1.85	1.85	1.85	1.9	2.07	2.06	2.06	2.1	2.29	2.29	2.29	2.3	2.55	2.55	2.55	2.6	2.85	2.85	2.84	2.9
	Amps	6.1	6.1	6.1	6.1	7.0	7.0	6.9	7.0	7.9	7.9	7.9	8.0	9.0	9.0	9.0	9.0	10.1	10.1	10.1	10.2	11.5	11.5	11.5	11.6
1060	MBh	29.5	29.9	30.8	32.1	29.2	29.6	30.5	31.8	28.5	28.9	29.8	31.1	27.2	27.6	28.4	29.8	25.6	26.0	26.9	28.2	24.1	24.5	25.4	26.7
	S/T	0.82	0.74	0.60	0.45	1.00	0.74	0.61	0.46	1.00	0.77	0.63	0.48	1.00	0.79	0.65	0.50	1.00	0.81	0.67	0.53	1.00	1.00	0.73	0.58
	ΔT	22	20	17	14	22	20	17	14	22	21	17	14	22	20	17	14	22	20	17	13	23	21	18	14
	kW	1.68	1.68	1.68	1.69	1.87	1.87	1.86	1.88	2.08	2.08	2.08	2.09	2.31	2.31	2.30	2.32	2.56	2.56	2.56	2.57	2.86	2.86	2.86	2.87
	Amps	6.2	6.2	6.1	6.2	7.0	7.0	7.0	7.1	8.0	8.0	8.0	8.0	9.0	9.0	9.0	9.1	10.2	10.2	10.2	10.3	11.6	11.6	11.6	11.6
1125	MBh	29.7	30.1	31.0	32.3	29.5	29.9	30.7	32.1	28.7	29.1	30.0	31.3	27.4	27.8	28.7	30.0	25.8	26.2	27.1	28.4	24.3	24.7	25.6	26.9
	S/T	0.84	0.76	0.62	0.47	1.00	0.77	0.63	0.48	1.00	0.79	0.65	0.50	1.00	0.81	0.67	0.52	1.00	1.00	0.69	0.55	1.00	1.00	0.75	0.60
	ΔT	22	20	17	13	22	20	17	13	22	20	17	13	22	20	17	13	21	20	16	13	23	21	17	14
	kW	1.68	1.68	1.68	1.7	1.87	1.87	1.87	1.9	2.08	2.08	2.08	2.1	2.31	2.31	2.31	2.3	2.57	2.57	2.56	2.6	2.87	2.87	2.86	2.9
	Amps	6.2	6.2	6.2	6.2	7.0	7.0	7.0	7.1	8.0	8.0	8.0	8.1	9.1	9.1	9.0	9.1	10.2	10.2	10.2	10.3	11.6	11.6	11.6	11.6

IDB: Entering Indoor Dry Bulb Temperature
 High and low pressures are measured at the liquid and suction service valves.
 Shaded area reflects ACCA (TVA) Rating Conditions.
 kW = Total system power
 Amps = Outdoor unit amps (compressor + fan)

COOLING DATA — ALZ55BA3010A*+AMST30BU1300A* (CONT.)

IDB	AIRFLOW	OUTDOOR AMBIENT TEMPERATURE																																			
		65°F						75°F						85°F						95°F						105°F						115°F					
		59	63	67	71	71	71	59	63	67	71	71	71	59	63	67	71	71	71	59	63	67	71	71	71	59	63	67	71	71	71	59	63	67	71	71	71
80	MBh	29.1	29.5	30.4	31.7	31.7	28.9	29.3	30.2	31.5	31.5	28.1	28.5	29.4	30.7	30.7	26.8	27.2	28.1	29.4	29.4	25.2	25.6	26.5	27.8	27.8	23.7	24.2	25.0	26.4	26.4						
	S/T	1.00	0.77	0.63	0.49	0.49	1.00	0.78	0.64	0.49	0.49	1.00	0.80	0.67	0.52	0.52	1.00	1.00	0.69	0.54	0.54	1.00	1.00	0.71	0.56	0.56	1.00	1.00	0.76	0.61	0.61						
	ΔT	28	26	23	19	19	28	26	23	19	19	28	26	23	19	19	28	26	23	19	19	27	26	22	19	19	29	27	23	20	20						
	kW	1.67	1.67	1.66	1.7	1.7	1.86	1.85	1.85	1.9	1.9	2.07	2.07	2.06	2.1	2.1	2.30	2.29	2.29	2.3	2.3	2.55	2.55	2.55	2.6	2.6	2.85	2.85	2.85	2.9	2.9						
	Amps	6.1	6.1	6.1	6.1	6.1	7.0	7.0	6.9	7.0	7.0	7.9	7.9	7.9	8.0	8.0	9.0	9.0	9.0	9.0	9.0	10.1	10.1	10.1	10.2	10.2	11.5	11.5	11.5	11.6	11.6						
1060	MBh	29.6	30.1	30.9	32.3	32.3	29.4	29.8	30.7	32.0	32.0	28.6	29.0	29.9	31.2	31.2	27.3	27.7	28.6	29.9	29.9	25.7	26.1	27.0	28.3	28.3	24.3	24.7	25.5	26.9	26.9						
	S/T	1.00	0.87	0.73	0.58	0.58	1.00	0.87	0.73	0.59	0.59	1.00	0.90	0.76	0.61	0.61	1.00	1.00	0.78	0.63	0.63	1.00	1.00	0.80	0.66	0.66	1.00	1.00	0.86	0.71	0.71						
	ΔT	26	24	21	18	18	26	24	21	18	18	26	25	21	18	18	26	24	21	17	17	26	24	21	17	17	27	25	22	18	18						
	kW	1.68	1.68	1.68	1.69	1.69	1.87	1.87	1.87	1.88	1.88	2.08	2.08	2.08	2.09	2.09	2.31	2.31	2.31	2.32	2.32	2.57	2.56	2.56	2.57	2.57	2.86	2.86	2.86	2.87	2.87						
	Amps	6.2	6.2	6.1	6.2	6.2	7.0	7.0	7.0	7.1	7.1	8.0	8.0	8.0	8.0	8.0	9.0	9.0	9.0	9.1	9.1	10.2	10.2	10.2	10.3	10.3	11.6	11.6	11.6	11.6	11.6						
1125	MBh	29.9	30.3	31.1	32.5	32.5	29.6	30.0	30.9	32.2	32.2	28.8	29.3	30.1	31.4	31.4	27.5	27.9	28.8	30.1	30.1	25.9	26.3	27.2	28.5	28.5	24.5	24.9	25.8	27.1	27.1						
	S/T	1.00	0.89	0.75	0.60	0.60	1.00	0.89	0.75	0.61	0.61	1.00	0.92	0.78	0.63	0.63	1.00	1.00	0.80	0.65	0.65	1.00	1.00	0.82	0.68	0.68	1.00	1.00	0.88	0.73	0.73						
	ΔT	26	24	21	17	17	26	24	20	17	17	26	24	21	17	17	26	24	20	17	17	25	24	20	17	17	26	25	21	18	18						
	kW	1.69	1.68	1.68	1.7	1.7	1.87	1.87	1.87	1.87	1.87	2.09	2.08	2.08	2.1	2.1	2.31	2.31	2.31	2.3	2.3	2.57	2.57	2.56	2.6	2.6	2.87	2.87	2.86	2.9	2.9						
	Amps	6.2	6.2	6.2	6.2	6.2	7.1	7.1	7.0	7.1	7.1	8.0	8.0	8.0	8.1	8.1	9.1	9.1	9.1	9.1	9.1	10.2	10.2	10.2	10.3	10.3	11.6	11.6	11.6	11.6	11.6						

875	MBh	29.6	30.0	30.9	32.2	32.2	29.4	29.8	30.6	32.0	32.0	28.6	29.0	29.9	31.2	31.2	27.3	27.7	28.6	29.9	29.9	25.7	26.1	27.0	28.3	28.3	24.2	24.6	25.5	26.8	26.8
	S/T	1.00	0.88	0.74	0.59	0.59	1.00	1.00	0.74	0.60	0.60	1.00	1.00	0.77	0.62	0.62	1.00	1.00	0.79	0.64	0.64	1.00	1.00	0.81	0.67	0.67	1.00	1.00	0.81	0.72	0.72
	ΔT	31	29	26	23	23	31	29	26	23	23	31	30	26	23	23	31	29	26	23	23	31	29	26	22	22	32	30	27	23	23
	kW	1.67	1.67	1.67	1.7	1.7	1.86	1.86	1.85	1.9	1.9	2.07	2.07	2.07	2.1	2.1	2.30	2.30	2.29	2.3	2.3	2.55	2.55	2.55	2.6	2.6	2.85	2.85	2.85	2.9	2.9
	Amps	6.1	6.1	6.1	6.2	6.2	7.0	7.0	7.0	7.0	7.0	8.0	7.9	7.9	8.0	8.0	9.0	9.0	9.0	9.0	9.0	10.2	10.2	10.1	10.2	10.2	11.5	11.5	11.5	11.6	11.6
1060	MBh	30.1	30.5	31.4	32.7	32.7	29.9	30.3	31.2	32.5	32.5	29.1	29.5	30.4	31.7	31.7	27.8	28.2	29.1	30.4	30.4	26.2	26.6	27.5	28.8	28.8	24.8	25.2	26.0	27.4	27.4
	S/T	1.00	0.97	0.83	0.69	0.69	1.00	1.00	0.84	0.69	0.69	1.00	1.00	0.86	0.72	0.72	1.00	1.00	0.88	0.74	0.74	1.00	1.00	0.76	0.76	1.00	1.00	0.81	0.81	0.81	
	ΔT	30	28	25	21	21	30	28	24	21	21	30	28	25	21	21	30	28	24	21	21	29	28	24	21	21	30	29	25	22	22
	kW	1.68	1.68	1.68	1.69	1.69	1.87	1.87	1.87	1.88	1.88	2.08	2.08	2.08	2.09	2.09	2.31	2.31	2.31	2.32	2.32	2.57	2.57	2.56	2.58	2.58	2.87	2.87	2.86	2.88	2.88
	Amps	6.2	6.2	6.2	6.2	6.2	7.1	7.0	7.0	7.1	7.1	8.0	8.0	8.0	8.1	8.1	9.1	9.1	9.0	9.1	9.1	10.2	10.2	10.2	10.3	10.3	11.6	11.6	11.6	11.6	11.6
1125	MBh	30.4	30.8	31.6	33.0	33.0	30.1	30.5	31.4	32.7	32.7	29.3	29.7	30.6	31.9	31.9	28.0	28.4	29.3	30.6	30.6	26.4	26.8	27.7	29.0	29.0	25.0	25.4	26.2	27.6	27.6
	S/T	1.00	0.99	0.85	0.71	0.71	1.00	1.00	0.86	0.71	0.71	1.00	1.00	0.88	0.74	0.74	1.00	1.00	0.90	0.76	0.76	1.00	1.00	0.78	0.78	1.00	1.00	0.83	0.83	0.83	
	ΔT	29	27	24	21	21	29	27	24	21	21	29	28	24	21	21	29	27	24	21	21	29	27	24	20	20	30	28	25	21	21
	kW	1.69	1.69	1.68	1.7	1.7	1.88	1.88	1.88	1.87	1.87	2.09	2.09	2.08	2.1	2.1	2.32	2.32	2.31	2.3	2.3	2.57	2.57	2.57	2.6	2.6	2.87	2.87	2.87	2.9	2.9
	Amps	6.2	6.2	6.2	6.2	6.2	7.1	7.1	7.1	7.0	7.1	8.0	8.0	8.0	8.1	8.1	9.1	9.1	9.1	9.1	9.1	10.3	10.3	10.2	10.3	10.3	11.6	11.6	11.6	11.6	11.7

IDB: Entering Indoor Dry Bulb Temperature
 High and low pressures are measured at the liquid and suction service valves.
 Shaded area reflects AHRI Rating Conditions.
 kW = Total system power
 Amps = Outdoor unit amps (compressor + fan)

COOLING DATA — ALZS5BA3610A*+AMST42CU1300A*

IDB		OUTDOOR AMBIENT TEMPERATURE																																		
		65°F					75°F					85°F					95°F					105°F					115°F									
		59	63	67	71	75	59	63	67	71	75	59	63	67	71	75	59	63	67	71	75	59	63	67	71	75	59	63	67	71	75					
		ENTERING INDOOR WET BULB TEMPERATURE																																		
		ENTERING INDOOR WET BULB TEMPERATURE																																		
70	AIRFLOW	59	63	67	71	75	59	63	67	71	75	59	63	67	71	75	59	63	67	71	75	59	63	67	71	75	59	63	67	71	75	59	63	67	71	75
	MBh	35.9	36.4	37.5	-	-	35.6	36.1	37.1	-	-	34.6	35.1	36.2	-	-	33.0	33.5	34.6	-	-	31.0	31.5	32.6	-	-	29.2	29.7	30.8	-	-					
	S/T	0.59	0.51	0.37	-	-	0.60	0.52	0.38	-	-	0.62	0.55	0.41	-	-	1.00	0.56	0.43	-	-	1.00	0.59	0.45	-	-	1.00	0.64	0.50	-	-					
	ΔT	20	19	15	-	-	20	19	15	-	-	21	19	15	-	-	20	19	15	-	-	20	18	15	-	-	21	19	16	-	-					
	kW	2.04	2.03	2.03	-	-	2.28	2.28	2.27	-	-	2.55	2.55	2.54	-	-	2.84	2.84	2.84	-	-	3.17	3.17	3.16	-	-	3.55	3.55	3.55	-	-					
Amps	7.6	7.6	7.6	-	-	8.8	8.7	8.7	-	-	10.0	10.0	10.0	-	-	11.3	11.3	11.3	-	-	12.8	12.8	12.8	-	-	14.6	14.6	14.6	-	-						
1260	MBh	36.5	37.0	38.1	-	-	36.2	36.7	37.8	-	-	35.2	35.7	36.8	-	-	33.6	34.1	35.2	-	-	31.6	32.1	33.2	-	-	29.8	30.3	31.4	-	-					
	S/T	0.68	0.60	0.46	-	-	0.69	0.61	0.47	-	-	0.71	0.63	0.50	-	-	1.00	0.65	0.52	-	-	1.00	0.68	0.54	-	-	1.00	0.73	0.59	-	-					
	ΔT	19	17	14	-	-	19	17	14	-	-	19	17	14	-	-	19	17	14	-	-	19	17	13	-	-	20	18	14	-	-					
	kW	2.05	2.05	2.05	-	-	2.30	2.29	2.29	-	-	2.57	2.57	2.56	-	-	2.86	2.86	2.85	-	-	3.19	3.19	3.18	-	-	3.57	3.57	3.57	-	-					
	Amps	7.7	7.7	7.7	-	-	8.8	8.8	8.8	-	-	10.1	10.1	10.0	-	-	11.4	11.4	11.4	-	-	12.9	12.9	12.9	-	-	14.7	14.7	14.6	-	-					
1350	MBh	36.8	37.3	38.4	-	-	36.5	37.0	38.1	-	-	35.5	36.0	37.1	-	-	33.9	34.4	35.5	-	-	31.9	32.5	33.5	-	-	30.1	30.6	31.7	-	-					
	S/T	0.70	0.62	0.49	-	-	0.71	0.63	0.49	-	-	0.73	0.66	0.52	-	-	1.00	0.68	0.54	-	-	1.00	0.70	0.56	-	-	1.00	0.75	0.61	-	-					
	ΔT	18	17	13	-	-	18	16	13	-	-	19	17	13	-	-	18	16	13	-	-	18	16	13	-	-	19	17	14	-	-					
	kW	2.06	2.06	2.05	-	-	2.30	2.30	2.30	-	-	2.57	2.57	2.57	-	-	2.87	2.86	2.86	-	-	3.19	3.19	3.19	-	-	3.58	3.58	3.57	-	-					
	Amps	7.8	7.7	7.7	-	-	8.9	8.9	8.8	-	-	10.1	10.1	10.1	-	-	11.4	11.4	11.4	-	-	12.9	12.9	12.9	-	-	14.7	14.7	14.7	-	-					

75	MBh	35.9	36.4	37.5	39.1	35.6	36.1	37.2	38.8	34.6	35.1	36.2	37.9	33.0	33.5	34.6	36.2	31.0	31.5	32.6	34.3	29.2	29.7	30.8	32.5
	S/T	0.72	0.64	0.51	0.36	0.73	0.65	0.51	0.37	1.00	0.68	0.54	0.39	1.00	0.70	0.56	0.41	1.00	0.72	0.58	0.44	1.00	1.00	0.63	0.49
	ΔT	25	23	19	16	25	23	19	16	25	23	19	16	24	23	19	16	24	22	19	15	25	24	20	16
	kW	2.03	2.03	2.03	2.0	2.28	2.28	2.27	2.3	2.55	2.55	2.54	2.6	2.84	2.84	2.84	2.9	3.17	3.17	3.16	3.2	3.55	3.55	3.55	3.6
	Amps	7.6	7.6	7.6	7.7	8.7	8.7	8.7	8.8	10.0	10.0	10.0	10.0	11.3	11.3	11.3	11.4	12.8	12.8	12.8	12.9	14.6	14.6	14.6	14.6
1260	MBh	36.5	37.0	38.1	39.7	36.2	36.7	37.8	39.4	35.2	35.8	36.8	38.5	33.6	34.1	35.2	36.9	31.7	32.2	33.2	34.9	29.8	30.4	31.4	33.1
	S/T	0.81	0.73	0.60	0.45	1.00	0.74	0.60	0.46	1.00	0.77	0.63	0.48	1.00	0.79	0.65	0.50	1.00	0.81	0.67	0.52	1.00	1.00	0.72	0.58
	ΔT	23	21	18	14	23	21	18	14	23	21	18	14	23	21	18	14	23	21	17	14	24	22	19	15
	kW	2.05	2.05	2.05	2.06	2.29	2.29	2.29	2.31	2.57	2.56	2.56	2.58	2.86	2.86	2.85	2.87	3.19	3.18	3.18	3.20	3.57	3.57	3.56	3.58
	Amps	7.7	7.7	7.7	7.8	8.8	8.8	8.8	8.9	10.1	10.1	10.0	10.1	11.4	11.4	11.4	11.5	12.9	12.9	12.9	13.0	14.7	14.7	14.6	14.7
1350	MBh	36.8	37.3	38.4	40.0	36.5	37.0	38.1	39.7	35.6	36.1	37.1	38.8	33.9	34.4	35.5	37.2	32.0	32.5	33.5	35.2	30.2	30.7	31.7	33.4
	S/T	0.83	0.76	0.62	0.47	1.00	0.76	0.62	0.48	1.00	0.79	0.65	0.50	1.00	0.81	0.67	0.52	1.00	0.83	0.69	0.55	1.00	1.00	0.74	0.60
	ΔT	22	21	17	14	22	21	17	13	23	21	17	14	22	21	17	13	22	20	17	13	23	21	18	14
	kW	2.06	2.06	2.05	2.1	2.30	2.30	2.30	2.3	2.57	2.57	2.57	2.6	2.86	2.86	2.86	2.9	3.19	3.19	3.19	3.2	3.58	3.57	3.57	3.6
	Amps	7.7	7.7	7.7	7.8	8.9	8.8	8.8	8.9	10.1	10.1	10.1	10.2	11.4	11.4	11.4	11.5	12.9	12.9	12.9	13.0	14.7	14.7	14.7	14.7

IDB: Entering Indoor Dry Bulb Temperature
 High and low pressures are measured at the liquid and suction service valves.
 Shaded area reflects ACCA (TVA) Rating Conditions.
 kW = Total system power
 Amps = Outdoor unit amps (compressor + fan)

COOLING DATA —ALZS5BA3610A*+AMST42CU1300A* (CONT.)

IDB	AIRFLOW	OUTDOOR AMBIENT TEMPERATURE																							
		65°F				75°F				85°F				95°F				105°F				115°F			
		59	63	67	71	59	63	67	71	59	63	67	71	59	63	67	71	59	63	67	71	59	63	67	71
80	MBh	36.1	36.6	37.7	39.3	35.8	36.3	37.3	39.0	34.8	35.3	36.4	38.0	33.2	33.7	34.8	36.4	31.2	31.7	32.8	34.5	29.4	29.9	31.0	32.6
	S/T	1.00	0.77	0.63	0.49	1.00	0.78	0.64	0.49	1.00	0.80	0.67	0.52	1.00	1.00	0.69	0.54	1.00	1.00	0.71	0.56	1.00	1.00	0.76	0.62
	ΔT	29	27	23	20	29	27	23	20	29	27	24	20	29	27	23	20	28	26	23	19	30	28	24	21
	kW	2.04	2.03	2.03	2.0	2.28	2.28	2.27	2.3	2.55	2.55	2.54	2.6	2.84	2.84	2.84	2.9	3.17	3.17	3.16	3.2	3.55	3.55	3.55	3.6
	Amps	7.6	7.6	7.6	7.7	8.8	8.7	8.7	8.8	10.0	10.0	10.0	10.1	11.3	11.3	11.3	11.4	12.8	12.8	12.8	12.9	14.6	14.6	14.6	14.6
1260	MBh	36.7	37.2	38.3	39.9	36.4	36.9	38.0	39.6	35.4	35.9	37.0	38.7	33.8	34.3	35.4	37.0	31.8	32.3	33.4	35.1	30.0	30.5	31.6	33.3
	S/T	1.00	0.86	0.72	0.58	1.00	0.87	0.73	0.58	1.00	0.89	0.75	0.61	1.00	1.00	0.77	0.63	1.00	1.00	0.80	0.65	1.00	1.00	0.85	0.70
	ΔT	27	25	22	18	27	25	22	18	27	25	22	18	27	25	22	18	27	25	21	18	28	26	23	19
	kW	2.05	2.05	2.05	2.07	2.30	2.29	2.29	2.31	2.57	2.57	2.56	2.58	2.86	2.86	2.85	2.87	3.19	3.19	3.18	3.20	3.57	3.57	3.57	3.58
	Amps	7.7	7.7	7.7	7.8	8.8	8.8	8.8	8.9	10.1	10.1	10.0	10.1	11.4	11.4	11.4	11.5	12.9	12.9	12.9	13.0	14.7	14.7	14.7	14.7
1350	MBh	37.0	37.5	38.6	40.2	36.7	37.2	38.3	39.9	35.7	36.3	37.3	39.0	34.1	34.6	35.7	37.4	32.1	32.7	33.7	35.4	30.3	30.9	31.9	33.6
	S/T	1.00	0.88	0.75	0.60	1.00	0.89	0.75	0.61	1.00	0.92	0.78	0.63	1.00	1.00	0.80	0.65	1.00	1.00	0.82	0.67	1.00	1.00	0.87	0.73
	ΔT	27	25	21	18	27	25	21	18	27	25	21	18	26	25	21	18	26	24	21	17	27	26	22	18
	kW	2.06	2.06	2.05	2.1	2.30	2.30	2.30	2.3	2.57	2.57	2.57	2.6	2.87	2.86	2.86	2.9	3.19	3.19	3.19	3.2	3.58	3.58	3.57	3.6
	Amps	7.8	7.7	7.7	7.8	8.9	8.9	8.8	8.9	10.1	10.1	10.1	10.2	11.4	11.4	11.4	11.5	12.9	12.9	12.9	13.0	14.7	14.7	14.7	14.8

85	MBh	36.7	37.2	38.3	39.9	36.4	36.9	38.0	39.6	35.4	35.9	37.0	38.7	33.8	34.3	35.4	37.0	31.8	32.3	33.4	35.1	30.0	30.5	31.6	33.3
	S/T	1.00	0.88	0.74	0.59	1.00	1.00	0.74	0.60	1.00	1.00	0.77	0.62	1.00	1.00	0.79	0.64	1.00	1.00	0.81	0.67	1.00	1.00	1.00	0.72
	ΔT	32	30	27	23	32	30	27	23	33	31	27	24	32	30	27	23	32	30	27	23	33	31	28	24
	kW	2.04	2.04	2.03	2.1	2.28	2.28	2.28	2.3	2.55	2.55	2.55	2.6	2.85	2.85	2.84	2.9	3.17	3.17	3.17	3.2	3.56	3.56	3.55	3.6
	Amps	7.7	7.7	7.6	7.7	8.8	8.8	8.7	8.8	10.0	10.0	10.0	10.1	11.4	11.3	11.3	11.4	12.9	12.8	12.8	12.9	14.6	14.6	14.6	14.7
1260	MBh	37.3	37.8	38.9	40.5	37.0	37.5	38.6	40.2	36.0	36.5	37.6	39.3	34.4	34.9	36.0	37.7	32.4	33.0	34.0	35.7	30.6	31.1	32.2	33.9
	S/T	1.00	0.96	0.83	0.68	1.00	1.00	0.83	0.69	1.00	1.00	0.86	0.71	1.00	1.00	0.88	0.73	1.00	1.00	1.00	0.75	1.00	1.00	1.00	0.81
	ΔT	31	29	25	22	31	29	25	22	31	29	26	22	31	29	25	22	30	29	25	22	32	30	26	23
	kW	2.06	2.06	2.05	2.07	2.30	2.30	2.29	2.31	2.57	2.57	2.57	2.58	2.86	2.86	2.86	2.88	3.19	3.19	3.19	3.20	3.58	3.57	3.57	3.59
	Amps	7.7	7.7	7.7	7.8	8.9	8.8	8.8	8.9	10.1	10.1	10.1	10.2	11.4	11.4	11.4	11.5	12.9	12.9	12.9	13.0	14.7	14.7	14.7	14.7
1350	MBh	37.6	38.1	39.2	40.8	37.3	37.8	38.9	40.5	36.4	36.9	37.9	39.6	34.7	35.2	36.3	38.0	32.8	33.3	34.3	36.0	31.0	31.5	32.5	34.2
	S/T	1.00	0.99	0.85	0.70	1.00	1.00	0.86	0.71	1.00	1.00	0.88	0.74	1.00	1.00	0.90	0.76	1.00	1.00	1.00	0.78	1.00	1.00	1.00	0.83
	ΔT	30	28	25	21	30	28	25	21	30	29	25	22	30	28	25	21	30	28	25	21	31	29	26	22
	kW	2.06	2.06	2.06	2.1	2.31	2.31	2.30	2.3	2.58	2.58	2.57	2.6	2.87	2.87	2.86	2.9	3.20	3.20	3.19	3.2	3.58	3.58	3.58	3.6
	Amps	7.8	7.8	7.7	7.8	8.9	8.9	8.9	8.9	10.1	10.1	10.1	10.2	11.5	11.5	11.4	11.5	13.0	13.0	12.9	13.0	14.7	14.7	14.7	14.8

IDB: Entering Indoor Dry Bulb Temperature
 High and low pressures are measured at the liquid and suction service valves.
 Shaded area reflects AHRI Rating Conditions.
 kW = Total system power
 Amps = Outdoor unit amps (compressor + fan)

COOLING DATA — ALZ55BA4210A*+AMST42CU1300A*

IDB	AIRFLOW	OUTDOOR AMBIENT TEMPERATURE												ENTERING INDOOR WET BULB TEMPERATURE											
		65°F				75°F				85°F				95°F				105°F				115°F			
		59	63	67	71	59	63	67	71	59	63	67	71	59	63	67	71	59	63	67	71	59	63	67	71
70	MBh	41.3	41.8	43.1	-	40.9	41.5	42.7	-	39.8	40.4	41.6	-	38.0	38.5	39.8	-	35.7	36.3	37.5	-	33.6	34.2	35.4	-
	S/T	0.61	0.53	0.40	-	0.62	0.54	0.41	-	0.64	0.57	0.43	-	0.66	0.58	0.45	-	1.00	0.61	0.47	-	1.00	0.66	0.52	-
	ΔT	19	17	14	-	19	17	14	-	19	18	14	-	19	17	14	-	19	17	14	-	20	18	15	-
	kW	2.35	2.35	2.35	-	2.63	2.62	2.62	-	2.93	2.93	2.92	-	3.26	3.26	3.25	-	3.63	3.62	3.62	-	4.06	4.06	4.05	-
	Amps	8.7	8.7	8.7	-	10.0	10.0	9.9	-	11.4	11.4	11.3	-	12.9	12.9	12.8	-	14.6	14.5	14.5	-	16.5	16.5	16.5	-
1225	MBh	41.7	42.3	43.6	-	41.4	42.0	43.2	-	40.3	40.9	42.1	-	38.4	39.0	40.3	-	36.2	36.8	38.0	-	34.1	34.7	35.9	-
	S/T	0.66	0.59	0.45	-	0.67	0.59	0.46	-	0.69	0.62	0.48	-	1.00	0.64	0.50	-	1.00	0.66	0.52	-	1.00	0.71	0.58	-
	ΔT	18	16	13	-	18	16	13	-	18	17	13	-	18	16	13	-	18	16	13	-	19	17	14	-
	kW	2.37	2.37	2.36	-	2.64	2.64	2.63	-	2.94	2.94	2.94	-	3.27	3.27	3.26	-	3.64	3.64	3.63	-	4.07	4.07	4.06	-
	Amps	8.8	8.8	8.8	-	10.0	10.0	10.0	-	11.4	11.4	11.4	-	12.9	12.9	12.9	-	14.6	14.6	14.6	-	16.6	16.6	16.6	-
1575	MBh	42.5	43.1	44.3	-	42.1	42.7	43.9	-	41.0	41.6	42.9	-	39.2	39.8	41.0	-	36.9	37.5	38.7	-	34.9	35.4	36.7	-
	S/T	0.70	0.62	0.49	-	0.70	0.63	0.49	-	0.73	0.65	0.52	-	1.00	0.67	0.54	-	1.00	0.70	0.56	-	1.00	0.75	0.61	-
	ΔT	17	15	12	-	17	15	12	-	17	16	12	-	17	15	12	-	17	15	12	-	18	16	13	-
	kW	2.38	2.38	2.37	-	2.65	2.65	2.65	-	2.96	2.95	2.95	-	3.28	3.28	3.28	-	3.65	3.65	3.65	-	4.08	4.08	4.08	-
	Amps	8.9	8.8	8.8	-	10.1	10.1	10.1	-	11.5	11.5	11.5	-	13.0	13.0	13.0	-	14.7	14.7	14.6	-	16.6	16.6	16.6	-

75	MBh	41.3	41.9	43.1	45.0	40.9	41.5	42.7	44.6	39.8	40.4	41.6	43.5	38.0	38.6	39.8	41.7	35.7	36.3	37.5	39.4	33.7	34.2	35.5	37.3
	S/T	0.74	0.66	0.53	0.39	0.74	0.67	0.53	0.39	1.00	0.69	0.56	0.42	1.00	0.71	0.58	0.44	1.00	0.74	0.60	0.46	1.00	1.00	0.65	0.51
	ΔT	23	21	18	14	23	21	18	14	23	21	18	15	23	21	18	14	23	21	18	14	24	22	19	15
	kW	2.35	2.35	2.35	2.4	2.62	2.62	2.62	2.6	2.93	2.93	2.92	2.9	3.26	3.26	3.25	3.3	3.62	3.62	3.62	3.6	4.06	4.05	4.05	4.1
	Amps	8.7	8.7	8.7	8.8	10.0	10.0	9.9	10.0	11.4	11.4	11.3	11.4	12.9	12.9	12.8	12.9	14.5	14.5	14.5	14.6	16.5	16.5	16.5	16.6
1380	MBh	41.8	42.4	43.6	45.5	41.4	42.0	43.2	45.1	40.3	40.9	42.1	44.0	38.5	39.1	40.3	42.2	36.2	36.8	38.0	39.9	34.1	34.7	36.0	37.8
	S/T	0.79	0.71	0.58	0.44	0.80	0.72	0.59	0.44	1.00	0.75	0.61	0.47	1.00	0.77	0.63	0.49	1.00	0.79	0.65	0.51	1.00	1.00	0.70	0.56
	ΔT	22	20	17	14	22	20	17	13	22	20	17	14	22	20	17	13	22	20	17	13	23	21	18	14
	kW	2.37	2.36	2.36	2.38	2.64	2.64	2.63	2.65	2.94	2.94	2.93	2.96	3.27	3.27	3.26	3.28	3.64	3.63	3.63	3.65	4.07	4.07	4.06	4.08
	Amps	8.8	8.8	8.8	8.8	10.0	10.0	10.0	10.1	11.4	11.4	11.4	11.5	12.9	12.9	12.9	13.0	14.6	14.6	14.6	14.7	16.6	16.6	16.5	16.6
1575	MBh	42.5	43.1	44.3	46.2	42.1	42.7	44.0	45.8	41.1	41.7	42.9	44.8	39.2	39.8	41.0	42.9	37.0	37.5	38.8	40.6	34.9	35.5	36.7	38.6
	S/T	0.83	0.75	0.62	0.47	1.00	0.76	0.62	0.48	1.00	0.78	0.65	0.51	1.00	0.80	0.67	0.52	1.00	0.82	0.69	0.55	1.00	1.00	0.74	0.60
	ΔT	21	19	16	12	21	19	16	12	21	19	16	13	21	19	16	12	21	19	16	12	22	20	17	13
	kW	2.38	2.38	2.37	2.4	2.65	2.65	2.64	2.7	2.95	2.95	2.95	3.0	3.28	3.28	3.28	3.3	3.65	3.65	3.64	3.7	4.08	4.08	4.07	4.1
	Amps	8.8	8.8	8.8	8.9	10.1	10.1	10.1	10.2	11.5	11.5	11.4	11.5	13.0	13.0	13.0	13.0	14.7	14.7	14.6	14.7	16.6	16.6	16.6	16.7

IDB: Entering Indoor Dry Bulb Temperature
 High and low pressures are measured at the liquid and suction service valves.
 Shaded area reflects ACCA (TVA) Rating Conditions.
 kW = Total system power
 Amps = Outdoor unit amps (compressor + fan)

COOLING DATA — ALZ55BA4210A*+AMST42CU1300A* (CONT.)

IDB	AIRFLOW	OUTDOOR AMBIENT TEMPERATURE																							
		65°F				75°F				85°F				95°F				105°F				115°F			
		59	63	67	71	59	63	67	71	59	63	67	71	59	63	67	71	59	63	67	71	59	63	67	71
80	MBh	41.5	42.1	43.3	45.2	41.1	41.7	42.9	44.8	40.0	40.6	41.9	43.7	38.2	38.8	40.0	41.9	35.9	36.5	37.7	39.6	33.9	34.5	35.7	37.6
	S/T	1.00	0.79	0.65	0.51	1.00	0.79	0.66	0.52	1.00	0.82	0.68	0.54	1.00	0.84	0.70	0.56	1.00	1.00	0.72	0.58	1.00	1.00	0.78	0.63
	ΔT	27	25	22	18	27	25	22	18	27	25	22	19	27	25	22	18	27	25	22	18	28	26	23	19
	kW	2.35	2.35	2.35	2.4	2.63	2.62	2.62	2.6	2.93	2.93	2.92	2.9	3.26	3.26	3.25	3.3	3.63	3.62	3.62	3.6	4.06	4.05	4.05	4.1
	Amps	8.7	8.7	8.7	8.8	10.0	10.0	9.9	10.0	11.4	11.4	11.3	11.4	12.9	12.9	12.8	12.9	14.6	14.5	14.5	14.6	16.5	16.5	16.5	16.6
1225	MBh	42.0	42.6	43.8	45.7	41.6	42.2	43.4	45.3	40.5	41.1	42.4	44.2	38.7	39.3	40.5	42.4	36.4	37.0	38.2	40.1	34.4	34.9	36.2	38.1
	S/T	1.00	0.84	0.70	0.56	1.00	0.85	0.71	0.57	1.00	0.87	0.74	0.59	1.00	1.00	0.76	0.61	1.00	1.00	0.78	0.64	1.00	1.00	0.83	0.69
	ΔT	26	24	21	17	26	24	21	17	26	24	21	18	26	24	21	17	26	24	21	17	27	25	22	18
	kW	2.37	2.36	2.36	2.38	2.64	2.64	2.63	2.65	2.94	2.94	2.94	2.96	3.27	3.27	3.26	3.29	3.64	3.64	3.63	3.65	4.07	4.07	4.06	4.08
	Amps	8.8	8.8	8.8	8.9	10.0	10.0	10.0	10.1	11.4	11.4	11.4	11.5	12.9	12.9	12.9	13.0	14.6	14.6	14.6	14.7	16.6	16.6	16.6	16.6
1575	MBh	42.7	43.3	44.5	46.4	42.4	42.9	44.2	46.1	41.3	41.9	43.1	45.0	39.4	40.0	41.2	43.1	37.2	37.8	39.0	40.9	35.1	35.7	36.9	38.8
	S/T	1.00	0.88	0.74	0.60	1.00	0.88	0.75	0.61	1.00	0.91	0.77	0.63	1.00	1.00	0.79	0.65	1.00	1.00	0.81	0.67	1.00	1.00	0.86	0.72
	ΔT	25	23	20	16	25	23	20	16	25	23	20	17	25	23	20	16	25	23	20	16	26	24	21	17
	kW	2.38	2.38	2.37	2.4	2.65	2.65	2.65	2.7	2.96	2.95	2.95	3.0	3.28	3.28	3.28	3.3	3.65	3.65	3.65	3.7	4.08	4.08	4.08	4.1
	Amps	8.9	8.8	8.8	8.9	10.1	10.1	10.1	10.2	11.5	11.5	11.5	11.5	13.0	13.0	13.0	13.1	14.7	14.7	14.6	14.7	16.6	16.6	16.6	16.7

85	MBh	42.2	42.8	44.0	45.9	41.8	42.4	43.6	45.5	40.7	41.3	42.6	44.4	38.9	39.5	40.7	42.6	36.6	37.2	38.4	40.3	34.6	35.1	36.4	38.3
	S/T	1.00	0.89	0.75	0.61	1.00	0.89	0.76	0.62	1.00	1.00	0.78	0.64	1.00	1.00	0.80	0.66	1.00	1.00	0.83	0.68	1.00	1.00	1.00	0.73
	ΔT	30	29	25	22	30	29	25	22	31	29	26	22	30	29	25	22	30	28	25	22	31	29	26	23
	kW	2.36	2.36	2.35	2.4	2.63	2.63	2.62	2.6	2.94	2.93	2.93	2.9	3.26	3.26	3.26	3.3	3.63	3.63	3.62	3.6	4.06	4.06	4.06	4.1
	Amps	8.8	8.7	8.7	8.8	10.0	10.0	10.0	10.1	11.4	11.4	11.4	11.5	12.9	12.9	12.9	13.0	14.6	14.6	14.5	14.6	16.5	16.5	16.5	16.6
1380	MBh	42.7	43.3	44.5	46.4	42.3	42.9	44.1	46.0	41.2	41.8	43.0	44.9	39.4	40.0	41.2	43.1	37.1	37.7	38.9	40.8	35.1	35.6	36.9	38.7
	S/T	1.00	0.94	0.81	0.66	1.00	1.00	0.81	0.67	1.00	1.00	0.84	0.69	1.00	1.00	0.86	0.71	1.00	1.00	0.88	0.74	1.00	1.00	1.00	0.79
	ΔT	29	28	24	21	29	28	24	21	30	28	25	21	29	28	24	21	29	27	24	21	30	28	25	22
	kW	2.37	2.37	2.37	2.39	2.64	2.64	2.64	2.66	2.95	2.95	2.94	2.96	3.28	3.27	3.27	3.29	3.64	3.64	3.64	3.66	4.07	4.07	4.07	4.09
	Amps	8.8	8.8	8.8	8.9	10.1	10.0	10.0	10.1	11.4	11.4	11.4	11.5	13.0	12.9	12.9	13.0	14.6	14.6	14.6	14.7	16.6	16.6	16.6	16.7
1575	MBh	43.4	44.0	45.2	47.1	43.1	43.6	44.9	46.7	42.0	42.6	43.8	45.7	40.1	40.7	41.9	43.8	37.9	38.4	39.7	41.6	35.8	36.4	37.6	39.5
	S/T	1.00	0.98	0.84	0.70	1.00	1.00	0.85	0.71	1.00	1.00	0.87	0.73	1.00	1.00	0.89	0.75	1.00	1.00	1.00	0.77	1.00	1.00	1.00	0.82
	ΔT	28	27	23	20	28	27	23	20	29	27	24	20	28	27	23	20	28	26	23	20	29	27	24	21
	kW	2.39	2.38	2.38	2.4	2.66	2.66	2.65	2.7	2.96	2.96	2.95	3.0	3.29	3.29	3.28	3.3	3.66	3.65	3.65	3.7	4.09	4.09	4.08	4.1
	Amps	8.9	8.9	8.8	8.9	10.1	10.1	10.1	10.2	11.5	11.5	11.5	11.6	13.0	13.0	13.0	13.1	14.7	14.7	14.7	14.8	16.7	16.7	16.6	16.7

IDB: Entering Indoor Dry Bulb Temperature
 High and low pressures are measured at the liquid and suction service valves.
 Shaded area reflects AHRI Rating Conditions.
 kW = Total system power
 Amps = Outdoor unit amps (compressor + fan)

COOLING DATA — ALZ55BA4810A*+AMST48CU1300A*

IDB	AIRFLOW	OUTDOOR AMBIENT TEMPERATURE																							
		65°F				75°F				85°F				95°F				105°F				115°F			
		59	63	67	71	59	63	67	71	59	63	67	71	59	63	67	71	59	63	67	71	59	63	67	71
70	MBh	46.9	47.6	48.9	-	46.5	47.1	48.5	-	45.3	45.9	47.3	-	43.2	43.9	45.2	-	40.7	41.3	42.7	-	38.3	39.0	40.4	-
	S/T	0.67	0.59	0.45	-	0.67	0.60	0.46	-	0.70	0.62	0.49	-	1.00	0.64	0.51	-	1.00	0.66	0.53	-	1.00	0.71	0.58	-
	ΔT	19	17	14	-	19	17	14	-	19	17	14	-	19	17	14	-	19	17	13	-	20	18	14	-
	kW	2.65	2.64	2.64	-	2.96	2.95	2.95	-	3.30	3.30	3.29	-	3.68	3.67	3.67	-	4.09	4.09	4.09	-	4.58	4.58	4.58	-
	Amps	9.8	9.8	9.7	-	11.2	11.2	11.2	-	12.8	12.8	12.7	-	14.5	14.5	14.5	-	16.4	16.4	16.4	-	18.7	18.6	18.6	-
70	MBh	47.3	48.0	49.4	-	46.9	47.6	48.9	-	45.7	46.3	47.7	-	43.6	44.3	45.6	-	41.1	41.7	43.1	-	38.7	39.4	40.8	-
	S/T	0.69	0.61	0.48	-	0.70	0.62	0.48	-	0.72	0.64	0.51	-	1.00	0.66	0.53	-	1.00	0.69	0.55	-	1.00	0.74	0.60	-
	ΔT	18	16	13	-	18	16	13	-	19	17	13	-	18	16	13	-	18	16	13	-	19	17	14	-
	kW	2.65	2.65	2.65	-	2.96	2.96	2.96	-	3.31	3.31	3.30	-	3.68	3.68	3.68	-	4.10	4.10	4.09	-	4.59	4.59	4.59	-
	Amps	9.8	9.8	9.8	-	11.2	11.2	11.2	-	12.8	12.8	12.8	-	14.5	14.5	14.5	-	16.4	16.4	16.4	-	18.7	18.7	18.7	-
70	MBh	48.2	48.8	50.2	-	47.8	48.4	49.8	-	46.6	47.2	48.6	-	44.5	45.1	46.5	-	42.0	42.6	44.0	-	39.6	40.3	41.7	-
	S/T	0.71	0.63	0.50	-	0.72	0.64	0.50	-	1.00	0.67	0.53	-	1.00	0.69	0.55	-	1.00	0.71	0.57	-	1.00	0.76	0.62	-
	ΔT	17	16	12	-	17	16	12	-	18	16	12	-	17	15	12	-	17	15	12	-	18	16	13	-
	kW	2.67	2.67	2.66	-	2.98	2.97	2.97	-	3.32	3.32	3.32	-	3.70	3.70	3.69	-	4.12	4.11	4.11	-	4.61	4.60	4.60	-
	Amps	9.9	9.9	9.8	-	11.3	11.3	11.3	-	12.9	12.9	12.8	-	14.6	14.6	14.6	-	16.5	16.5	16.5	-	18.8	18.7	18.7	-

75	MBh	46.9	47.6	49.0	51.1	46.5	47.2	48.5	50.7	45.3	46.0	47.3	49.5	43.2	43.9	45.3	47.4	40.7	41.3	42.7	44.8	38.4	39.0	40.4	42.5
	S/T	0.80	0.72	0.58	0.44	1.00	0.73	0.59	0.45	1.00	0.75	0.62	0.47	1.00	0.77	0.63	0.49	1.00	0.79	0.66	0.51	1.00	1.00	1.00	0.57
	ΔT	23	21	18	14	23	21	18	14	23	21	18	14	23	21	18	14	23	21	17	14	24	22	19	15
	kW	2.64	2.64	2.64	2.7	2.95	2.95	2.95	3.0	3.30	3.30	3.29	3.3	3.67	3.67	3.67	3.7	4.09	4.09	4.08	4.1	4.58	4.58	4.58	4.6
	Amps	9.8	9.8	9.7	9.8	11.2	11.2	11.2	11.3	12.8	12.8	12.7	12.8	14.5	14.5	14.4	14.6	16.4	16.4	16.4	16.5	18.6	18.6	18.6	18.7
75	MBh	47.3	48.0	49.4	51.5	46.9	47.6	49.0	51.1	45.7	46.4	47.8	49.9	43.6	44.3	45.7	47.8	41.1	41.8	43.1	45.2	38.8	39.4	40.8	42.9
	S/T	0.82	0.74	0.61	0.46	1.00	0.75	0.61	0.47	1.00	0.77	0.64	0.50	1.00	0.79	0.66	0.51	1.00	0.82	0.68	0.54	1.00	1.00	0.73	0.59
	ΔT	22	21	17	14	22	21	17	13	23	21	17	14	22	21	17	13	22	20	17	13	23	21	18	14
	kW	2.65	2.65	2.64	2.67	2.96	2.96	2.95	2.98	3.31	3.31	3.30	3.32	3.68	3.68	3.67	3.70	4.10	4.10	4.09	4.12	4.59	4.59	4.58	4.61
	Amps	9.8	9.8	9.8	9.9	11.2	11.2	11.2	11.3	12.8	12.8	12.8	12.9	14.5	14.5	14.5	14.6	16.4	16.4	16.4	16.5	18.7	18.7	18.6	18.8
75	MBh	48.2	48.9	50.3	52.4	47.8	48.5	49.8	52.0	46.6	47.3	48.6	50.7	44.5	45.2	46.6	48.7	42.0	42.6	44.0	46.1	39.7	40.3	41.7	43.8
	S/T	0.84	0.76	0.63	0.48	1.00	0.77	0.63	0.49	1.00	0.79	0.66	0.52	1.00	0.81	0.68	0.54	1.00	1.00	0.70	0.56	1.00	1.00	0.75	0.61
	ΔT	21	20	16	13	21	20	16	13	22	20	16	13	21	20	16	13	21	19	16	12	22	20	17	13
	kW	2.67	2.66	2.66	2.7	2.98	2.97	2.97	3.0	3.32	3.32	3.31	3.3	3.70	3.69	3.69	3.7	4.11	4.11	4.11	4.1	4.60	4.60	4.60	4.6
	Amps	9.9	9.9	9.8	9.9	11.3	11.3	11.3	11.4	12.9	12.9	12.8	12.9	14.6	14.6	14.5	14.7	16.5	16.5	16.5	16.6	18.7	18.7	18.7	18.8

IDB: Entering Indoor Dry Bulb Temperature
 High and low pressures are measured at the liquid and suction service valves.
 Shaded area reflects ACCA (TVA) Rating Conditions.
 kW = Total system power
 Amps = Outdoor unit amps (compressor + fan)

COOLING DATA — ALZ5BA4810A*+AMST48CU1300A* (CONT.)

IDB	AIRFLOW	OUTDOOR AMBIENT TEMPERATURE																							
		65°F				75°F				85°F				95°F				105°F				115°F			
		59	63	67	71	59	63	67	71	59	63	67	71	59	63	67	71	59	63	67	71	59	63	67	71
80	MBh	47.2	47.8	49.2	51.3	46.8	47.4	48.8	50.9	45.5	46.2	47.6	49.7	43.5	44.1	45.5	47.6	40.9	41.6	43.0	45.1	38.6	39.3	40.6	42.8
	S/T	1.00	0.85	0.71	0.57	1.00	0.88	0.74	0.60	1.00	0.88	0.74	0.60	1.00	1.00	0.76	0.62	1.00	1.00	0.78	0.64	1.00	1.00	0.83	0.69
	ΔT	27	25	22	18	27	25	22	18	27	25	22	18	27	25	22	18	27	25	21	18	28	26	23	19
	kW	2.65	2.64	2.64	2.7	2.96	2.95	2.95	3.0	3.30	3.30	3.29	3.3	3.68	3.67	3.67	3.7	4.09	4.09	4.09	4.1	4.58	4.58	4.58	4.6
	Amps	9.8	9.8	9.7	9.9	11.2	11.2	11.2	11.3	12.8	12.8	12.7	12.9	14.5	14.5	14.5	14.6	16.4	16.4	16.4	16.5	18.7	18.6	18.6	18.7
1490	MBh	47.6	48.2	49.6	51.7	47.2	47.8	49.2	51.3	46.0	46.6	48.0	50.1	43.9	44.5	45.9	48.0	41.3	42.0	43.4	45.5	39.0	39.7	41.1	43.2
	S/T	1.00	0.87	0.73	0.59	1.00	0.87	0.74	0.60	1.00	0.90	0.76	0.62	1.00	1.00	0.78	0.64	1.00	1.00	0.81	0.66	1.00	1.00	0.86	0.71
	ΔT	27	25	21	18	26	25	21	18	27	25	21	18	26	25	21	18	26	24	21	17	27	26	22	18
	kW	2.65	2.65	2.65	2.67	2.96	2.96	2.96	2.98	3.31	3.31	3.30	3.33	3.68	3.68	3.68	3.70	4.10	4.10	4.09	4.12	4.59	4.59	4.59	4.61
	Amps	9.8	9.8	9.8	9.9	11.2	11.2	11.2	11.3	12.8	12.8	12.8	12.9	14.5	14.5	14.5	14.6	16.4	16.4	16.4	16.5	18.7	18.7	18.7	18.8
1600	MBh	48.5	49.1	50.5	52.6	48.0	48.7	50.1	52.2	46.8	47.5	48.9	51.0	44.8	45.4	46.8	48.9	42.2	42.9	44.3	46.4	39.9	40.6	41.9	44.0
	S/T	1.00	0.89	0.75	0.61	1.00	0.90	0.76	0.62	1.00	1.00	0.78	0.64	1.00	1.00	0.80	0.66	1.00	1.00	0.83	0.68	1.00	1.00	1.00	0.73
	ΔT	26	24	20	17	26	24	20	17	26	24	20	17	26	24	20	17	25	23	20	16	26	25	21	18
	kW	2.67	2.66	2.66	2.7	2.98	2.97	2.97	3.0	3.32	3.32	3.32	3.3	3.70	3.69	3.69	3.7	4.12	4.11	4.11	4.1	4.61	4.60	4.60	4.6
	Amps	9.9	9.9	9.8	9.9	11.3	11.3	11.3	11.4	12.9	12.9	12.8	13.0	14.6	14.6	14.6	14.7	16.5	16.5	16.5	16.6	18.8	18.7	18.7	18.8

85	MBh	47.9	48.6	50.0	52.1	47.5	48.2	49.6	51.7	46.3	47.0	48.4	50.5	44.2	44.9	46.3	48.4	41.7	42.4	43.7	45.9	39.4	40.0	41.4	43.5
	S/T	1.00	0.95	0.81	0.67	1.00	1.00	0.82	0.67	1.00	1.00	0.84	0.70	1.00	1.00	0.86	0.72	1.00	1.00	1.00	0.74	1.00	1.00	1.00	0.79
	ΔT	31	29	25	22	31	29	25	22	31	29	26	22	31	29	25	22	30	29	25	22	32	30	26	23
	kW	2.65	2.65	2.64	2.7	2.96	2.96	2.95	3.0	3.31	3.30	3.30	3.3	3.68	3.68	3.67	3.7	4.10	4.10	4.09	4.1	4.59	4.59	4.58	4.6
	Amps	9.8	9.8	9.8	9.9	11.2	11.2	11.2	11.3	12.8	12.8	12.8	12.9	14.5	14.5	14.5	14.6	16.4	16.4	16.4	16.5	18.7	18.7	18.6	18.8
1490	MBh	48.4	49.0	50.4	52.5	47.9	48.6	50.0	52.1	46.7	47.4	48.8	50.9	44.7	45.3	46.7	48.8	42.1	42.8	44.2	46.3	39.8	40.4	41.8	43.9
	S/T	1.00	0.97	0.83	0.69	1.00	1.00	0.84	0.70	1.00	1.00	0.87	0.72	1.00	1.00	0.88	0.74	1.00	1.00	1.00	0.76	1.00	1.00	1.00	0.82
	ΔT	30	28	25	21	30	28	25	21	30	29	25	21	30	28	25	21	30	28	25	21	31	29	26	22
	kW	2.66	2.66	2.65	2.68	2.97	2.97	2.96	2.99	3.32	3.31	3.31	3.33	3.69	3.69	3.68	3.71	4.11	4.11	4.10	4.12	4.60	4.60	4.59	4.61
	Amps	9.8	9.8	9.8	9.9	11.3	11.2	11.2	11.3	12.8	12.8	12.8	12.9	14.6	14.5	14.5	14.6	16.5	16.5	16.4	16.5	18.7	18.7	18.7	18.8
1600	MBh	49.2	49.9	51.3	53.4	48.8	49.5	50.9	53.0	47.6	48.3	49.7	51.8	45.5	46.2	47.6	49.7	43.0	43.7	45.0	47.1	40.7	41.3	42.7	44.8
	S/T	1.00	0.99	0.85	0.71	1.00	1.00	0.86	0.72	1.00	1.00	0.89	0.74	1.00	1.00	0.91	0.76	1.00	1.00	1.00	0.78	1.00	1.00	1.00	0.84
	ΔT	29	27	24	20	29	27	24	20	29	28	24	21	29	27	24	20	29	27	24	20	30	28	25	21
	kW	2.67	2.67	2.67	2.7	2.98	2.98	2.98	3.0	3.33	3.33	3.32	3.3	3.70	3.70	3.70	3.7	4.12	4.12	4.11	4.1	4.61	4.61	4.60	4.6
	Amps	9.9	9.9	9.9	10.0	11.3	11.3	11.3	11.4	12.9	12.9	12.9	13.0	14.6	14.6	14.6	14.7	16.5	16.5	16.5	16.6	18.8	18.8	18.7	18.9

IDB: Entering Indoor Dry Bulb Temperature
 High and low pressures are measured at the liquid and suction service valves.
 Shaded area reflects AHRI Rating Conditions.
 kW = Total system power
 Amps = Outdoor unit amps (compressor + fan)

COOLING DATA — ALZ55BA6010A*+AMST60DU1300A*

IDB	AIRFLOW	OUTDOOR AMBIENT TEMPERATURE																							
		65°F				75°F				85°F				105°F				115°F							
		59	63	67	71	59	63	67	71	59	63	67	71	59	63	67	71	59	63	67	71				
70	MBh	58.8	59.6	61.3	-	58.2	59.1	60.8	-	56.7	57.5	59.3	-	54.1	54.9	56.7	-	50.9	51.7	53.5	-	48.0	48.8	50.6	-
	S/T	0.65	0.58	0.44	-	0.66	0.58	0.45	-	0.68	0.61	0.47	-	0.70	0.63	0.49	-	1.00	0.65	0.52	-	1.00	0.70	0.57	-
	ΔT	20	18	14	-	20	18	14	-	20	18	14	-	19	18	14	-	19	17	14	-	20	19	15	-
	kW	3.41	3.41	3.40	-	3.83	3.82	3.82	-	4.29	4.29	4.28	-	4.80	4.80	4.79	-	5.36	5.36	5.35	-	6.03	6.02	6.01	-
	Amps	12.7	12.6	12.6	-	14.6	14.6	14.5	-	16.7	16.7	16.7	-	19.0	19.0	19.0	-	21.6	21.6	21.6	-	24.6	24.6	24.6	-
70	MBh	59.5	60.3	62.1	-	59.0	59.8	61.5	-	57.5	58.3	60.0	-	54.9	55.7	57.4	-	51.7	52.5	54.2	-	48.8	49.6	51.3	-
	S/T	0.68	0.61	0.47	-	0.69	0.61	0.48	-	0.71	0.64	0.50	-	0.73	0.66	0.52	-	1.00	0.68	0.54	-	1.00	0.73	0.59	-
	ΔT	19	17	13	-	19	17	13	-	19	17	13	-	19	17	13	-	18	16	13	-	20	18	14	-
	kW	3.42	3.42	3.41	-	3.84	3.84	3.83	-	4.31	4.31	4.30	-	4.81	4.81	4.80	-	5.38	5.38	5.37	-	6.04	6.04	6.03	-
	Amps	12.7	12.7	12.7	-	14.6	14.6	14.6	-	16.8	16.8	16.7	-	19.1	19.1	19.0	-	21.7	21.7	21.6	-	24.7	24.7	24.7	-
70	MBh	60.7	61.5	63.3	-	60.2	61.0	62.7	-	58.7	59.5	61.2	-	56.1	56.9	58.6	-	52.9	53.7	55.4	-	50.0	50.8	52.5	-
	S/T	0.70	0.62	0.49	-	0.70	0.63	0.49	-	0.73	0.65	0.52	-	1.00	0.67	0.54	-	1.00	0.69	0.56	-	1.00	0.74	0.61	-
	ΔT	18	16	12	-	18	16	12	-	18	16	12	-	18	16	12	-	17	16	12	-	19	17	13	-
	kW	3.44	3.44	3.43	-	3.86	3.86	3.85	-	4.33	4.32	4.32	-	4.83	4.83	4.82	-	5.40	5.39	5.39	-	6.06	6.06	6.05	-
	Amps	12.8	12.8	12.8	-	14.7	14.7	14.7	-	16.9	16.8	16.8	-	19.2	19.2	19.1	-	21.8	21.7	21.7	-	24.8	24.8	24.7	-

IDB	AIRFLOW	OUTDOOR AMBIENT TEMPERATURE																							
		65°F				75°F				85°F				105°F				115°F							
		59	63	67	71	59	63	67	71	59	63	67	71	59	63	67	71	59	63	67	71				
75	MBh	58.8	59.6	61.3	64.0	58.3	59.1	60.8	63.5	56.8	57.6	59.3	62.0	54.1	55.0	56.7	59.3	51.0	51.8	53.5	56.2	48.1	48.9	50.6	53.3
	S/T	0.78	0.70	0.57	0.43	0.78	0.71	0.58	0.44	1.00	0.73	0.60	0.46	1.00	0.75	0.62	0.48	1.00	0.77	0.64	0.50	1.00	0.82	0.69	0.55
	ΔT	24	22	18	15	24	22	18	15	24	22	18	15	24	22	18	15	23	22	18	14	25	23	19	15
	kW	3.41	3.40	3.40	3.4	3.82	3.82	3.81	3.8	4.29	4.29	4.28	4.3	4.80	4.79	4.79	4.8	5.36	5.36	5.35	5.4	6.02	6.02	6.01	6.0
	Amps	12.6	12.6	12.6	12.7	14.6	14.5	14.5	14.7	16.7	16.7	16.6	16.8	19.0	19.0	19.0	19.1	21.6	21.6	21.5	21.7	24.6	24.6	24.6	24.7
75	MBh	59.5	60.4	62.1	64.7	59.0	59.8	61.6	64.2	57.5	58.3	60.1	62.7	54.9	55.7	57.5	60.1	51.7	52.5	54.3	56.9	48.8	49.6	51.4	54.0
	S/T	0.81	0.73	0.60	0.46	0.81	0.74	0.61	0.47	1.00	0.76	0.63	0.49	1.00	0.78	0.65	0.51	1.00	0.80	0.67	0.53	1.00	1.00	0.72	0.58
	ΔT	23	21	17	14	23	21	17	14	23	21	18	14	23	21	17	14	23	21	17	13	24	22	18	15
	kW	3.42	3.42	3.41	3.44	3.84	3.84	3.83	3.86	4.31	4.30	4.30	4.33	4.81	4.81	4.80	4.83	5.38	5.37	5.37	5.40	6.04	6.03	6.03	6.06
	Amps	12.7	12.7	12.7	12.8	14.6	14.6	14.6	14.7	16.8	16.7	16.7	16.9	19.1	19.1	19.0	19.2	21.7	21.6	21.6	21.8	24.7	24.7	24.6	24.8
75	MBh	60.7	61.6	63.3	65.9	60.2	61.0	62.8	65.4	58.7	59.5	61.3	63.9	56.1	56.9	58.6	61.3	52.9	53.7	55.5	58.1	50.0	50.8	52.6	55.2
	S/T	0.82	0.75	0.61	0.47	0.83	0.75	0.62	0.48	1.00	0.78	0.64	0.51	1.00	0.80	0.66	0.52	1.00	0.82	0.69	0.55	1.00	1.00	0.74	0.60
	ΔT	22	20	16	13	22	20	16	13	22	20	17	13	22	20	16	13	22	20	16	12	23	21	17	14
	kW	3.44	3.44	3.43	3.5	3.86	3.85	3.85	3.9	4.32	4.32	4.31	4.3	4.83	4.83	4.82	4.9	5.39	5.39	5.38	5.4	6.06	6.05	6.05	6.1
	Amps	12.8	12.8	12.7	12.9	14.7	14.7	14.7	14.8	16.8	16.8	16.8	16.9	19.2	19.1	19.1	19.3	21.7	21.7	21.7	21.8	24.8	24.8	24.7	24.9

IDB: Entering Indoor Dry Bulb Temperature
 High and low pressures are measured at the liquid and suction service valves.
 Shaded area reflects ACCA (TVA) Rating Conditions.
 kW = Total system power
 Amps = Outdoor unit amps (compressor + fan)

COOLING DATA — ALZS5BA6010A*+AMST60DU1300A* (CONT.)

IDB	AIRFLOW	OUTDOOR AMBIENT TEMPERATURE																							
		65°F				75°F				85°F				95°F				105°F				115°F			
		59	63	67	71	59	63	67	71	59	63	67	71	59	63	67	71	59	63	67	71	59	63	67	71
80	MBh	59.1	59.9	61.6	64.3	58.6	59.4	61.1	63.8	57.1	57.9	59.6	62.3	54.4	55.3	57.0	59.6	51.3	52.1	53.8	56.5	48.4	49.2	50.9	53.6
	S/T	0.90	0.83	0.69	0.55	1.00	0.83	0.70	0.56	1.00	0.86	0.72	0.58	1.00	0.88	0.74	0.60	1.00	1.00	0.76	0.62	1.00	1.00	0.81	0.67
	ΔT	28	26	23	19	28	26	22	19	28	26	22	19	28	26	22	19	28	26	22	18	29	27	23	20
	kW	3.41	3.40	3.40	3.4	3.83	3.82	3.82	3.8	4.29	4.29	4.28	4.3	4.80	4.79	4.79	4.8	5.36	5.36	5.35	5.4	6.02	6.02	6.01	6.0
	Amps	12.7	12.6	12.6	12.8	14.6	14.6	14.5	14.7	16.7	16.7	16.7	16.8	19.0	19.0	19.0	19.1	21.6	21.6	21.5	21.7	24.6	24.6	24.6	24.7
2000	MBh	59.8	60.7	62.4	65.0	59.3	60.1	61.9	64.5	57.8	58.6	60.4	63.0	55.2	56.0	57.8	60.4	52.0	52.8	54.6	57.2	49.1	49.9	51.7	54.3
	S/T	1.00	0.85	0.72	0.58	1.00	0.86	0.73	0.59	1.00	0.89	0.75	0.61	1.00	0.90	0.77	0.63	1.00	1.00	0.79	0.65	1.00	1.00	0.84	0.70
	ΔT	27	25	22	18	27	25	22	18	27	25	22	18	27	25	22	18	27	25	21	18	28	26	23	19
	kW	3.42	3.42	3.41	3.44	3.84	3.84	3.83	3.86	4.31	4.31	4.30	4.33	4.81	4.81	4.80	4.84	5.38	5.37	5.37	5.40	6.04	6.04	6.03	6.06
	Amps	12.7	12.7	12.7	12.8	14.6	14.6	14.6	14.7	16.8	16.8	16.7	16.9	19.1	19.1	19.1	19.2	21.7	21.7	21.6	21.8	24.7	24.7	24.7	24.8
2250	MBh	61.0	61.9	63.6	66.2	60.5	61.3	63.1	65.7	59.0	59.8	61.6	64.2	56.4	57.2	58.9	61.6	53.2	54.0	55.8	58.4	50.3	51.1	52.9	55.5
	S/T	1.00	0.87	0.74	0.60	1.00	0.88	0.74	0.60	1.00	0.90	0.77	0.63	1.00	1.00	0.79	0.65	1.00	1.00	0.81	0.67	1.00	1.00	0.86	0.72
	ΔT	26	24	21	17	26	24	21	17	26	25	21	17	26	24	21	17	26	24	20	17	27	25	22	18
	kW	3.44	3.44	3.43	3.5	3.86	3.86	3.85	3.9	4.33	4.32	4.32	4.3	4.83	4.83	4.82	4.9	5.40	5.39	5.39	5.4	6.06	6.05	6.05	6.1
	Amps	12.8	12.8	12.8	12.9	14.7	14.7	14.7	14.8	16.9	16.8	16.8	17.0	19.2	19.2	19.1	19.3	21.8	21.7	21.7	21.8	24.8	24.8	24.7	24.9

85	MBh	60.1	60.9	62.6	65.3	59.5	60.4	62.1	64.7	58.0	58.8	60.6	63.2	55.4	56.2	58.0	60.6	52.2	53.1	54.8	57.4	49.3	50.2	51.9	54.5
	S/T	1.00	0.92	0.79	0.65	1.00	0.93	0.80	0.66	1.00	1.00	0.82	0.68	1.00	1.00	0.84	0.70	1.00	1.00	0.86	0.72	1.00	1.00	1.00	0.77
	ΔT	32	30	26	23	32	30	26	23	32	30	27	23	32	30	26	23	31	30	26	22	33	31	27	23
	kW	3.42	3.41	3.41	3.4	3.83	3.83	3.82	3.9	4.30	4.30	4.29	4.3	4.81	4.80	4.80	4.8	5.37	5.37	5.36	5.4	6.03	6.03	6.02	6.1
	Amps	12.7	12.7	12.6	12.8	14.6	14.6	14.6	14.7	16.7	16.7	16.7	16.8	19.1	19.0	19.0	19.1	21.6	21.6	21.6	21.7	24.7	24.6	24.6	24.8
2000	MBh	60.8	61.6	63.4	66.0	60.3	61.1	62.9	65.5	58.8	59.6	61.3	64.0	56.2	57.0	58.7	61.4	53.0	53.8	55.5	58.2	50.1	50.9	52.6	55.3
	S/T	1.00	0.95	0.82	0.68	1.00	0.96	0.83	0.69	1.00	1.00	0.85	0.71	1.00	1.00	0.87	0.73	1.00	1.00	0.89	0.75	1.00	1.00	1.00	0.80
	ΔT	31	29	25	22	31	29	25	22	31	29	26	22	31	29	25	22	31	29	25	21	32	30	26	23
	kW	3.43	3.43	3.42	3.45	3.85	3.85	3.84	3.87	4.32	4.31	4.31	4.34	4.82	4.82	4.81	4.84	5.39	5.38	5.38	5.41	6.05	6.04	6.04	6.07
	Amps	12.8	12.7	12.7	12.9	14.7	14.7	14.6	14.8	16.8	16.8	16.8	16.9	19.1	19.1	19.1	19.2	21.7	21.7	21.7	21.8	24.7	24.7	24.7	24.8
2250	MBh	62.0	62.8	64.6	67.2	61.5	62.3	64.0	66.7	60.0	60.8	62.5	65.2	57.4	58.2	59.9	62.6	54.2	55.0	56.7	59.4	51.3	52.1	53.8	56.5
	S/T	1.00	0.97	0.84	0.70	1.00	1.00	0.84	0.70	1.00	1.00	0.87	0.73	1.00	1.00	0.89	0.75	1.00	1.00	0.91	0.77	1.00	1.00	1.00	0.82
	ΔT	30	28	24	21	30	28	24	21	30	28	25	21	30	28	24	21	30	28	24	20	31	29	25	22
	kW	3.45	3.45	3.44	3.5	3.87	3.86	3.86	3.9	4.33	4.33	4.32	4.4	4.84	4.84	4.83	4.9	5.40	5.40	5.39	5.4	6.07	6.06	6.06	6.1
	Amps	12.8	12.8	12.8	12.9	14.8	14.7	14.7	14.9	16.9	16.9	16.8	17.0	19.2	19.2	19.2	19.3	21.8	21.8	21.7	21.9	24.8	24.8	24.8	24.9

IDB: Entering Indoor Dry Bulb Temperature
 High and low pressures are measured at the liquid and suction service valves.
 Shaded area reflects AHRI Rating Conditions.
 kW = Total system power
 Amps = Outdoor unit amps (compressor + fan)

HEATING DATA

ALZS5BA1810A*+AMST24BU1300A*

	OUTDOOR AMBIENT TEMPERATURE																
	65	60	55	50	47	45	40	35	30	25	20	17	15	10	5	0	-5
MBh	23.38	21.82	20.28	18.77	17.80	17.07	15.24	13.56	12.19	11.17	10.41	10.00	9.48	8.18	6.88	5.58	4.28
T/R	31.54	29.72	27.89	26.07	24.97	23.95	21.38	19.02	17.10	15.67	14.60	14.03	13.30	11.48	9.65	7.83	6.00
KW	1.41	1.39	1.37	1.34	1.33	1.32	1.30	1.28	1.25	1.23	1.21	1.19	1.18	1.16	1.14	1.11	1.09
AMPS	5.1	5.0	4.9	4.8	4.7	4.7	4.6	4.5	4.4	4.3	4.2	4.1	4.1	4.0	3.9	3.8	3.7
COP	4.84	4.60	4.34	4.09	3.92	3.79	3.44	3.12	2.85	2.67	2.53	2.46	2.35	2.07	1.78	1.47	1.15

ALZS5BA2410A*+AMST24BU1300A*

	OUTDOOR AMBIENT TEMPERATURE																
	65	60	55	50	47	45	40	35	30	25	20	17	15	10	5	0	-5
MBh	30.16	28.15	26.18	24.24	23.00	22.07	19.72	17.56	15.81	14.50	13.52	13.00	12.33	10.67	9.00	7.33	5.67
T/R	34.88	32.87	30.87	28.86	27.66	26.54	23.71	21.12	19.01	17.44	16.26	15.63	14.83	12.83	10.82	8.82	6.81
KW	1.86	1.81	1.77	1.73	1.70	1.68	1.64	1.60	1.56	1.51	1.47	1.44	1.43	1.38	1.34	1.30	1.25
AMPS	6.9	6.7	6.5	6.3	6.2	6.1	5.9	5.7	5.5	5.4	5.2	5.1	5.0	4.8	4.6	4.4	4.2
COP	4.76	4.55	4.33	4.11	3.96	3.84	3.52	3.22	2.98	2.81	2.70	2.64	2.53	2.26	1.97	1.66	1.33

ALZS5BA3010A*+AMST30BU1300A*

	OUTDOOR AMBIENT TEMPERATURE																
	65	60	55	50	47	45	40	35	30	25	20	17	15	10	5	0	-5
MBh	36.73	34.46	32.22	30.02	28.60	27.57	24.97	22.52	20.52	19.05	17.98	17.40	16.65	14.79	12.92	11.05	9.19
T/R	30.85	29.22	27.59	25.96	24.98	24.10	21.81	19.67	17.93	16.64	15.70	15.20	14.55	12.92	11.29	9.65	8.02
KW	2.28	2.27	2.25	2.23	2.22	2.21	2.19	2.17	2.16	2.14	2.12	2.11	2.10	2.08	2.06	2.04	2.03
AMPS	8.2	8.2	8.1	8.0	8.0	7.9	7.8	7.8	7.7	7.6	7.5	7.5	7.4	7.4	7.3	7.2	7.1
COP	4.71	4.46	4.20	3.95	3.78	3.66	3.34	3.04	2.79	2.61	2.49	2.42	2.32	2.08	1.84	1.58	1.33

ALZS5BA3610A*+AMST42CU1300A*

	OUTDOOR AMBIENT TEMPERATURE																
	65	60	55	50	47	45	40	35	30	25	20	17	15	10	5	0	-5
MBh	45.76	42.75	39.78	36.87	35.00	33.61	30.08	26.85	24.21	22.25	20.78	20.00	19.00	16.50	14.00	11.50	9.00
T/R	32.34	30.50	28.66	26.82	25.72	24.70	22.11	19.73	17.79	16.35	15.27	14.70	13.96	12.12	10.29	8.45	6.61
KW	2.83	2.76	2.69	2.62	2.58	2.55	2.48	2.41	2.34	2.27	2.20	2.16	2.13	2.06	1.99	1.92	1.85
AMPS	10.3	10.0	9.7	9.4	9.2	9.1	8.8	8.5	8.2	7.9	7.6	7.4	7.2	6.9	6.6	6.3	6.0
COP	4.74	4.54	4.33	4.12	3.98	3.86	3.56	3.27	3.03	2.88	2.77	2.72	2.62	2.35	2.07	1.76	1.43

Above information is for nominal CFM and 70 degree indoor dry bulb. Instantaneous capacity listed.

Amps = Outdoor unit amps (comp.+fan)

kW = Total system power

Goodman Manufacturing Company, L.P. reserves the right to discontinue, or change at any time, specifications or designs without notice or without incurring obligations.

ALZS5BA4210A*+AMST42CU1300A*

	OUTDOOR AMBIENT TEMPERATURE																
	65	60	55	50	47	45	40	35	30	25	20	17	15	10	5	0	-5
MBh	50.75	47.60	44.51	41.46	39.50	38.08	34.47	31.09	28.32	26.29	24.80	24.00	22.97	20.38	17.80	15.22	12.63
T/R	32.75	31.01	29.28	27.54	26.50	25.56	23.13	20.86	19.00	17.64	16.64	16.10	15.41	13.68	11.94	10.21	8.48
KW	3.28	3.21	3.15	3.08	3.05	3.02	2.96	2.89	2.83	2.77	2.70	2.66	2.64	2.58	2.51	2.45	2.38
AMPS	12.1	11.8	11.5	11.2	11.1	10.9	10.7	10.4	10.1	9.8	9.6	9.4	9.3	9.0	8.7	8.5	8.2
COP	4.54	4.34	4.14	3.94	3.80	3.69	3.42	3.15	2.93	2.79	2.69	2.64	2.55	2.32	2.08	1.82	1.55

ALZS5BA4810A*+AMST48CU1300A*

	OUTDOOR AMBIENT TEMPERATURE																
	65	60	55	50	47	45	40	35	30	25	20	17	15	10	5	0	-5
MBh	59.07	55.41	51.82	48.28	46.00	44.35	40.16	36.23	33.02	30.65	28.93	28.00	26.80	23.80	20.80	17.80	14.80
T/R	35.30	33.44	31.57	29.71	28.59	27.57	24.96	22.52	20.52	19.05	17.98	17.40	16.65	14.79	12.93	11.06	9.20
KW	3.65	3.58	3.51	3.45	3.40	3.38	3.31	3.24	3.17	3.10	3.04	3.00	2.97	2.90	2.83	2.76	2.69
AMPS	13.5	13.2	12.9	12.6	12.4	12.3	12.0	11.7	11.4	11.1	10.8	10.7	10.5	10.2	9.9	9.6	9.4
COP	4.74	4.53	4.32	4.11	3.96	3.85	3.56	3.28	3.05	2.89	2.79	2.74	2.65	2.41	2.15	1.89	1.61

ALZS5BA6010A*+AMST60DU1300A*

	OUTDOOR AMBIENT TEMPERATURE																
	65	60	55	50	47	45	40	35	30	25	20	17	15	10	5	0	-5
MBh	71.76	67.64	63.58	59.59	57.00	55.11	50.60	46.06	42.53	39.89	38.01	37.00	35.67	32.33	29.00	25.67	22.33
T/R	35.30	33.59	31.89	30.18	29.16	28.26	25.89	23.62	21.75	20.40	19.44	18.93	18.25	16.54	14.83	13.13	11.42
KW	4.28	4.22	4.16	4.11	4.07	4.05	4.00	3.94	3.88	3.83	3.77	3.74	3.72	3.66	3.61	3.55	3.49
AMPS	15.7	15.5	15.2	15.0	14.8	14.7	14.5	14.3	14.0	13.8	13.5	13.4	13.3	13.0	12.8	12.6	12.3
COP	4.92	4.70	4.48	4.25	4.10	3.99	3.71	3.43	3.21	3.05	2.95	2.90	2.81	2.59	2.36	2.12	1.87

Above information is for nominal CFM and 70 degree indoor dry bulb. Instantaneous capacity listed.

Amps = Outdoor unit amps (comp.+fan)

kW = Total system power

Goodman Manufacturing Company, L.P. reserves the right to discontinue, or change at any time, specifications or designs without notice or without incurring obligations.

PERFORMANCE DATA

MODEL: ALZS5BA1810A*+AMST24BU1300A*				
CONDITIONS: 80 °F IBD, 67 °F IWB @ 660 CFM				
OUTDOOR TEM. ° F.	TOTAL BTU/H	SENSIBLE BTU/H	LATENT BTU/H	TOTAL WATTS
75	19,300	14,000	5,300	1,170
80	19,060	14,065	4,995	1,240
85	18,820	14,130	4,690	1,310
90	18,410	13,995	4,415	1,380
95	18,000	13,860	4,140	1,450
100	17,495	13,665	3,830	1,530
105	16,990	13,470	3,520	1,610
110	16,535	13,525	3,010	1,705
115	16,080	13,580	2,500	1,800
TVA CONDITIONS @ 95° OD DB, 75° ID DB 63° ID WB				
95°	17,358	13,549	3,809	1,452

MODEL: ALZS5BA2410A*+AMST24BU1300A*				
CONDITIONS: 80 °F IBD, 67 °F IWB @ 770 CFM				
OUTDOOR TEM. ° F.	TOTAL BTU/H	SENSIBLE BTU/H	LATENT BTU/H	TOTAL WATTS
75	24,880	17,570	7,310	1,500
80	24,570	17,655	6,915	1,590
85	24,260	17,740	6,520	1,680
90	23,730	17,575	6,155	1,775
95	23,200	17,410	5,790	1,870
100	22,550	17,160	5,390	1,980
105	21,900	16,910	4,990	2,090
110	21,310	16,980	4,330	2,215
115	20,720	17,050	3,670	2,340
TVA CONDITIONS @ 95° OD DB, 75° ID DB 63° ID WB				
95°	22,372	17,010	5,363	1,872

MODEL: ALZS5BA3010A*+AMST30BU1300A*				
CONDITIONS: 80 °F IBD, 67 °F IWB @ 1,060 CFM				
OUTDOOR TEM. ° F.	TOTAL BTU/H	SENSIBLE BTU/H	LATENT BTU/H	TOTAL WATTS
75	30,670	22,530	8,140	1,870
80	30,290	22,635	7,655	1,975
85	29,910	22,740	7,170	2,080
90	29,255	22,530	6,725	2,195
95	28,600	22,320	6,280	2,310
100	27,800	22,000	5,800	2,435
105	27,000	21,680	5,320	2,560
110	26,270	21,770	4,500	2,710
115	25,540	21,860	3,680	2,860
TVA CONDITIONS @ 95° OD DB, 75° ID DB 63° ID WB				
95°	27,580	21,808	5,772	2,307

MODEL: ALZS5BA3610A*+AMST42CU1300A*				
CONDITIONS: 80 °F IBD, 67 °F IWB @ 1,260 CFM				
OUTDOOR TEM. ° F.	TOTAL BTU/H	SENSIBLE BTU/H	LATENT BTU/H	TOTAL WATTS
75	37,960	27,690	10,270	2,290
80	37,490	27,820	9,670	2,425
85	37,020	27,950	9,070	2,560
90	36,210	27,690	8,520	2,705
95	35,400	27,430	7,970	2,850
100	34,410	27,040	7,370	3,015
105	33,420	26,650	6,770	3,180
110	32,520	26,760	5,760	3,375
115	31,620	26,870	4,750	3,570
TVA CONDITIONS @ 95° OD DB, 75° ID DB 63° ID WB				
95°	34,137	26,803	7,334	2,857

MODEL: ALZS5BA4210A*+AMST42CU1300A*				
CONDITIONS: 80 °F IBD, 67 °F IWB @ 1,380 CFM				
OUTDOOR TEM. ° F.	TOTAL BTU/H	SENSIBLE BTU/H	LATENT BTU/H	TOTAL WATTS
75	43,430	30,880	12,550	2,630
80	42,890	31,025	11,865	2,785
85	42,350	31,170	11,180	2,940
90	41,425	30,880	10,545	3,100
95	40,500	30,590	9,910	3,260
100	39,370	30,155	9,215	3,445
105	38,240	29,720	8,520	3,630
110	37,205	29,845	7,360	3,845
115	36,170	29,970	6,200	4,060
TVA CONDITIONS @ 95° OD DB, 75° ID DB 63° ID WB				
95°	39,055	29,892	9,164	3,268

MODEL: ALZS5BA4810A*+AMST48CU1300A*				
CONDITIONS: 80 °F IBD, 67 °F IWB @ 1,490 CFM				
OUTDOOR TEM. ° F.	TOTAL BTU/H	SENSIBLE BTU/H	LATENT BTU/H	TOTAL WATTS
75	48,790	34,920	13,870	2,950
80	48,185	35,085	13,100	3,120
85	47,580	35,250	12,330	3,290
90	46,540	34,920	11,620	3,480
95	45,500	34,590	10,910	3,670
100	44,230	34,100	10,130	3,880
105	42,960	33,610	9,350	4,090
110	41,800	33,750	8,050	4,335
115	40,640	33,890	6,750	4,580
TVA CONDITIONS @ 95° OD DB, 75° ID DB 63° ID WB				
95°	43,877	33,805	10,072	3,672

MODEL: ALZS5BA6010A*+AMST60DU1300A*				
CONDITIONS: 80 °F IBD, 67 °F IWB @ 1,810 CFM				
OUTDOOR TEM. ° F.	TOTAL BTU/H	SENSIBLE BTU/H	LATENT BTU/H	TOTAL WATTS
75	61,120	42,720	18,400	3,820
80	60,360	42,920	17,440	4,050
85	59,600	43,120	16,480	4,280
90	58,300	42,720	15,580	4,535
95	57,000	42,320	14,680	4,790
100	55,410	41,720	13,690	5,070
105	53,820	41,120	12,700	5,350
110	52,365	41,290	11,075	5,680
115	50,910	41,460	9,450	6,010
TVA Conditions @ 95° OD DB, 75° ID DB 63° ID WB				
95°	54,967	41,359	13,608	4,793

MODEL	DIMENSIONS		
	W"	D"	H"
ALZS5BA1810A*	29	29	39½
ALZS5BA2410A*	29	29	39½
ALZS5BA3010A*	35½	35½	39½
ALZS5BA3610A*	35½	35½	39½
ALZS5BA4210A*	35½	35½	35¾
ALZS5BA4810A*	35½	35½	36½
ALZS5BA6010A*	35½	35½	41¾

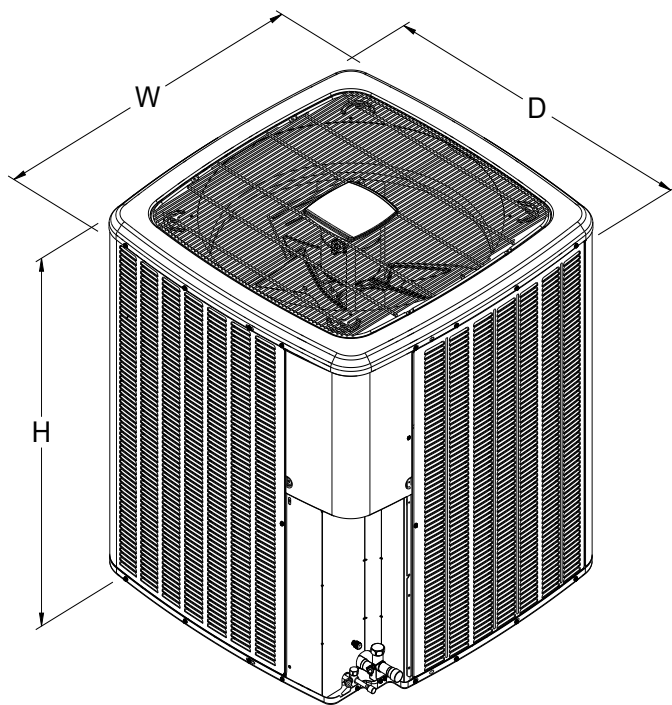

ACCESSORIES

MODEL #	DESCRIPTION	ALZS5BA 1810A*	ALZS5BA 2410A*	ALZS5BA 3010A*	ALZS5BA 3610A*	ALZS5BA 4210A*	ALZS5BA 4810A*	ALZS5BA 6010A*
ABK-20	Anchor Bracket Kit ◊	X	X	X	X	X	X	X
CSR-U-1	Hard-start Kit	X	X	X	X			
CSR-U-2	Hard-start Kit					X	X	X
CSR-U-3	Hard-start Kit						X	X
FSK01A ¹	Freeze Protection Kit	X	X	X	X	X	X	X
LAKT01	Low-Ambient Kit	X	X	X	X	X	X	X
OT18-60A ²	Outdoor Thermostat w/ Lockout Stat	X	X	X	X	X	X	X
0161R00128	Neutral Circular Cap	X	X	X	X	X	X	X

◊ Contains 20 brackets; four brackets needed to anchor unit to pad

¹ Installed on indoor coil

² Required for heat pump applications where ambient temperatures fall below 0°F with 50% or higher relative humidity.

All AHRI system ratings are accessible in the System Configurator tool via PartnerLink.