

## S-SERIES

UP TO 19 SEER2  
 2 TO 5 TONS

HIGH-EFFICIENCY,  
 VARIABLE-SPEED, INVERTER DRIVEN  
 R-32 SPLIT SYSTEM AIR CONDITIONER

### Contents

Nomenclature.....	2
Product Specifications.....	3
Expanded Cooling Data.....	4
Performance Data	
Standard Mode .....	12
Sound Power.....	14
Sound Power Levels.....	14
Sound Pressure.....	15
Wiring Diagrams .....	16
Dimensions .....	19
Accessories .....	22
AHRI Ratings (see note).....	22



### Standard Features

- Variable-speed swing compressors
- Quiet digitally commutated fan motor
- High-density compressor sound blanket
- Compatible with Amana Smart Thermostat and other Amana communicating equipment
- Proprietary control algorithmic logic
- In communicating mode, only two low-voltage wires to outdoor unit required
- Diagnostic indicator lights, seven-segment LED display, and fault code storage
- Proprietary Inside intelligence for diagnostics
- Field-selectable boost mode increases compressor speed during unusually high loads
- Field-installed filter drier
- Coil and ambient temperature sensors
- Suction pressure transducer
- Sweat connection service valves with easy access to gauge ports
- AHRI Certified; ETL Listed

### Cabinet Features

- Heavy-gauge galvanized steel cabinet with grille-style sound control side design
- Custom Ivory white powder-paint finish
- High corrosion-resistant (ZAM®), unpainted steel bottom frame and legs
- 500-hour salt-spray tested
- Wire fan discharge grille
- Top and side maintenance access
- When properly anchored, meets the 2023 Florida Building Code unit integrity requirements for hurricane-type winds (Anchor bracket kits available.)



COMPANY WITH ENVIRONMENTAL SYSTEM CERTIFIED BY DNV GL  
 = ISO 14001 =  
 COMPANY WITH QUALITY SYSTEM CERTIFIED BY DNV GL  
 = ISO 9001 =

\* Complete warranty available from your local dealer or at [www.amana-hac.com](http://www.amana-hac.com). To receive the 10-Year Unit Replacement Limited Warranty (good for as long as you own your home) and 10-Year Parts Limited Warranty, online registration must be completed within 60 days of installation. Online registration is not required in California, Florida, or Québec. The duration of warranty coverages in Texas and Florida differs in some cases. Changes in law, regulations, or technology may result in an equivalent unit not being available. Other limitations and exclusions apply, refer to complete warranty details for full list of limitations and exclusions, as well as rights and obligations should an equivalent unit not be available.

† One-time Unit Replacement coverage and One-time Compressor Replacement coverage is available to the original homeowner for years 11-99 after the installation date through an ASURE Extend Service Plan. Complete details about the Extended Service Plan options available from your ASURE dealer.

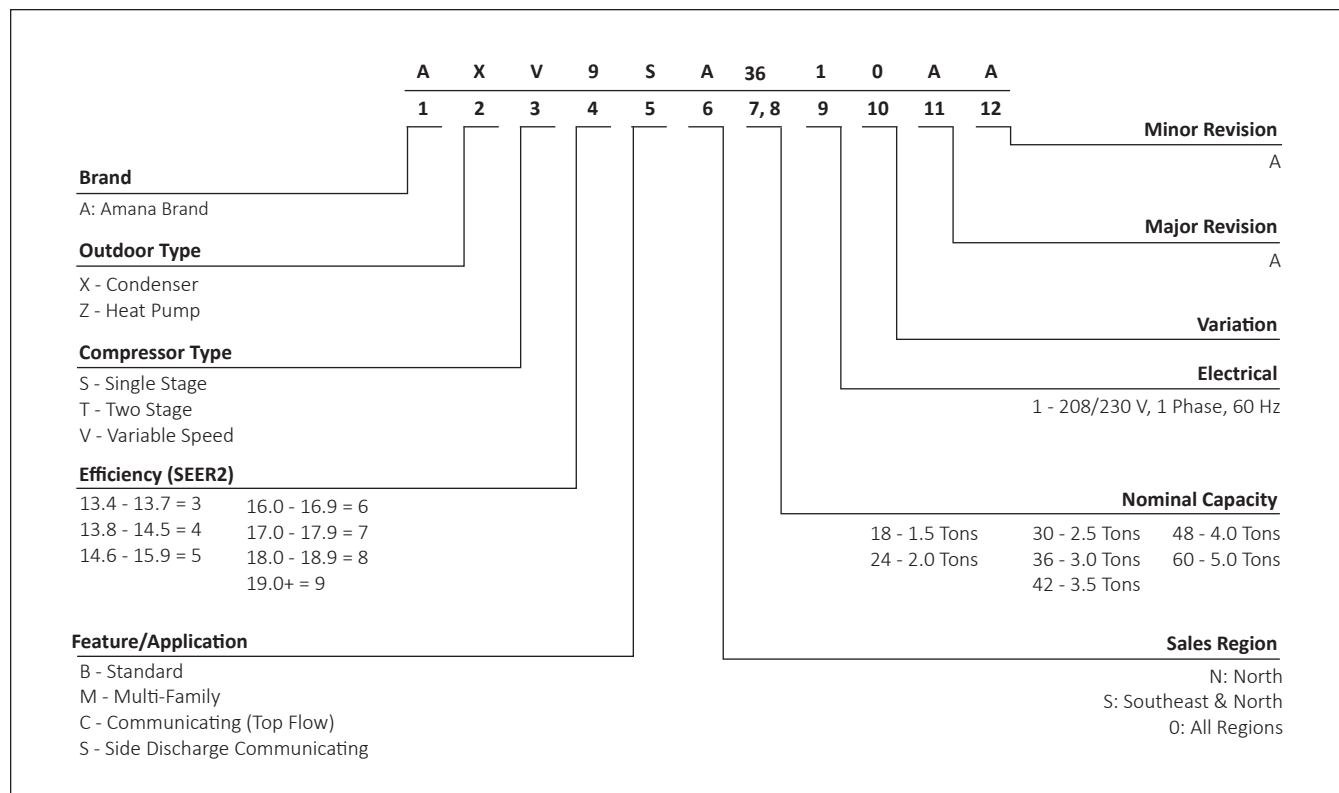

	AXV9S A2410A*	AXV9S A3610A*	AXV9S A4810A*	AXV9S A6010A*
<b>CAPACITY AND RATINGS</b>				
Max. Cooling (BTU/h)	23,200	35,000	46,500	57,000
<b>AMBIENT OPERATION RANGE</b>	0 to 115 (-17.8 to 46.1)			
COOLING (°FDB(°CDB))				
<b>COMPRESSOR</b>				
Type	Swing	Swing	Swing	Scroll
<b>CONDENSER FAN MOTOR</b>				
Horsepower	0.20	0.36	0.36	2 x 0.32
<b>REFRIGERATION SYSTEM</b>				
Refrigerant Line Size <sup>1</sup>				
Liquid Line Size ("O.D.)	3/8"	3/8"	3/8"	3/8"
Suction Line Size ("O.D.)	7/8"	1 1/8"	1 1/8"	1 1/8"
Refrigerant Connection Size				
Liquid Valve Size ("O.D.)	3/8"	3/8"	3/8"	3/8"
Suction Valve Size ("O.D.)	7/8"	7/8"	7/8"	7/8"
Valve Connection Type	Front Sealing	Front and Back Sealing	Front and Back Sealing	Front and Back Sealing
Refrigerant Charge (oz.)	76	100	118	162
Expansion Device	EEV	EEV	EEV	EEV
Superheat at Service Valve	Auto-control	Auto-control	Auto-control	Auto-control
Subcooling at Service Valve	14±1°F	8±1°F	9±1°F	11±1°F
<b>ELECTRICAL DATA</b>				
Voltage / Phase (60 Hz)	208-230/1	208-230/1	208-230/1	208-230/1
Fan/Compressor Inverter Drive Input	17.6	25.4	30	24.5
Minimum Circuit Ampacity <sup>2</sup>	22.4	31.8	37.5	34.4
Max. Overcurrent Protection <sup>3</sup>	25	35	40	40
Min / Max Volts	197/253	197/253	197/253	197/253
Electrical Conduit Size	1/2"	1/2" or 3/4"	1/2" or 3/4"	1/2" or 3/4"
<b>EQUIPMENT WEIGHT (LBS)</b>	129	163	174	236
<b>SHIP WEIGHT (LBS)</b>	143	183	196	271

<sup>1</sup> Tested and rated in accordance with AHRI Standard 210/240

<sup>2</sup> Wire size should be determined in accordance with National Electrical Codes; extensive wire runs will require larger wire sizes.

<sup>3</sup> Must use time-delay fuses or HACR-type circuit breakers of the same size as noted.

**NOTES**

- Always check the S&R plate for electrical data on the unit being installed.
- Installer will need to supply 7/8" to 1 1/8" adapters for suction line connections.
- Unit is charged with refrigerant for 15' of 3/8" liquid line. System charge must be adjusted per Installation Instructions Final Charge Procedure.

See a table below for allowable line set diameter.

UNIT TONS	ALLOWABLE LINE SET DIAMETER						
	LIQUID			SUCTION			
	1/4"	5/16"	3/8"	3/8"	3/4"	7/8"	1 1/8"
2.0		X	X	X	X <sup>1</sup>	X	
3.0			X	X		X	X
4.0			X	X		X	X
5.0			X			X	X

<b>OUTDOOR UNIT</b>	AXV9S*481*A*/ AXV9S*601*A*	TRIM MORE THAN 5% SETTINGS ARE INVALID. TRIMMED UP CFM MAKES MISS MATCHING ERROR.
<b>INDOOR UNIT</b>	A*VT960804C A*VM970804C A*VT800804C	

EXPANDED COOLING DATA — AXV9SA2410A\* / AHVE36CP1300A\*

IDB	AIRFLOW	OUTDOOR AMBIENT TEMPERATURE																																																																																																																																
		65°F				75°F				85°F				95°F				105°F				115°F																																																																																																												
		59	63	67	71	59	63	67	71	59	63	67	71	59	63	67	71	59	63	67	71	59	63	67	71																																																																																																									
70	680	MBh	25.2	25.6	26.3	24.4	24.7	25.5	23.1	23.5	24.2	21.5	21.8	22.5	19.6	20.0	20.6	18.0	18.3	19.0	0.58	0.50	0.37	0.59	0.51	0.38	0.64	0.56	0.43	0.66	0.59	0.45	1.01	0.64	0.51	ΔT	21	19	15	20	18	15	20	18	15	19	17	14	18	16	13	18	16	14	kW	1.54	1.54	1.53	1.71	1.71	1.71	1.90	1.90	1.90	2.10	2.10	2.10	2.32	2.32	2.32	2.58	2.58	2.58	Amps	5.5	5.5	5.5	6.2	6.2	6.2	6.9	6.9	6.9	7.7	7.7	7.7	8.5	8.5	8.5	9.5	9.4	9.4	Hi PR	260	262	263	302	303	305	345	346	348	391	392	394	441	443	444	495	496	498	Lo PR	120	123	130	126	129	136	131	134	141	135	138	145	138	142	149	143	147	154
		MBh	25.6	26.0	26.7	24.8	25.1	25.8	23.5	23.8	24.6	21.8	22.2	22.9	20.0	20.3	21.0	18.3	18.6	19.3	0.65	0.58	0.45	0.66	0.59	0.45	0.71	0.64	0.50	0.74	0.66	0.53	1.01	0.72	0.58	ΔT	19	17	14	19	17	13	18	17	13	17	16	12	17	15	12	17	15	12	kW	1.55	1.55	1.55	1.72	1.72	1.72	1.91	1.91	1.91	2.11	2.11	2.11	2.34	2.33	2.33	2.59	2.59	2.59	Amps	5.6	5.5	5.5	6.2	6.2	6.2	7.0	7.0	6.9	7.7	7.7	7.7	8.6	8.5	8.5	9.5	9.5	9.5	Hi PR	263	264	266	304	305	307	348	349	350	394	395	397	444	445	447	498	499	501	Lo PR	122	125	132	128	131	138	133	136	143	137	140	147	140	144	151	145	149	156
		MBh	26.1	26.5	27.2	25.2	25.6	26.3	24.0	24.3	25.0	22.3	22.6	23.3	20.4	20.8	21.4	18.8	19.1	19.7	0.69	0.62	0.48	0.69	0.62	0.48	0.75	0.68	0.54	0.78	0.70	0.57	1.01	0.76	0.62	ΔT	18	16	13	18	16	12	17	15	12	16	15	11	16	14	11	16	14	11	kW	1.56	1.56	1.56	1.73	1.73	1.73	1.92	1.92	1.92	2.12	2.12	2.12	2.34	2.34	2.34	2.60	2.60	2.60	Amps	5.6	5.6	5.6	6.3	6.3	6.3	7.0	7.0	7.0	7.8	7.8	7.7	8.6	8.6	8.6	9.5	9.5	9.5	Hi PR	266	267	269	307	308	310	350	351	353	397	398	400	447	448	450	500	501	503	Lo PR	124	127	134	130	134	141	135	139	146	139	142	150	143	146	154	148	151	159
		MBh	25.2	25.6	26.4	24.4	24.7	25.5	23.1	23.5	24.2	21.5	21.8	22.5	19.7	20.0	20.7	18.0	18.3	19.0	0.71	0.63	0.49	0.72	0.64	0.51	0.78	0.70	0.57	1.01	0.72	0.58	1.01	0.77	0.64	ΔT	25	23	20	24	22	19	24	22	18	22	21	18	21	20	17	22	20	17	kW	1.54	1.54	1.53	1.71	1.71	1.71	1.90	1.90	1.90	2.10	2.10	2.10	2.32	2.32	2.32	2.58	2.58	2.57	Amps	5.5	5.5	5.5	6.2	6.2	6.2	6.9	6.9	6.9	7.7	7.7	7.7	8.5	8.5	8.5	9.4	9.4	9.4	Hi PR	261	262	264	302	303	305	345	346	348	392	393	394	442	443	445	495	496	498	Lo PR	120	123	130	126	129	136	131	134	141	135	138	145	138	142	149	143	147	154
		MBh	25.6	26.0	26.7	24.8	25.1	25.8	23.5	23.8	24.6	21.8	22.2	22.9	20.4	20.8	21.4	18.8	19.1	19.7	0.69	0.62	0.48	0.70	0.63	0.49	0.75	0.68	0.54	0.78	0.70	0.57	1.01	0.76	0.62	ΔT	18	16	13	18	16	12	17	15	12	16	15	11	16	14	11	16	14	11	kW	1.56	1.56	1.56	1.73	1.73	1.73	1.92	1.92	1.92	2.12	2.12	2.12	2.34	2.34	2.34	2.60	2.60	2.60	Amps	5.6	5.6	5.6	6.3	6.3	6.3	7.0	7.0	7.0	7.8	7.8	7.7	8.6	8.6	8.6	9.5	9.5	9.5	Hi PR	266	267	269	307	308	310	350	351	353	397	398	400	447	448	450	500	501	503	Lo PR	124	127	134	130	134	141	135	139	146	139	142	150	143	146	154	148	151	159

75	680	MBh	25.2	25.6	26.4	24.4	24.7	25.5	23.1	23.5	24.2	21.5	21.8	22.5	19.7	20.0	20.7	18.0	18.3	19.0	0.71	0.63	0.49	0.72	0.64	0.51	0.78	0.70	0.57	1.01	0.72	0.58	1.01	0.77	0.64	ΔT	25	23	20	24	22	19	24	22	18	22	21	18	21	20	17	22	20	17	kW	1.54	1.54	1.53	1.71	1.71	1.71	1.90	1.90	1.90	2.10	2.10	2.10	2.32	2.32	2.32	2.58	2.58	2.57	Amps	5.5	5.5	5.5	6.2	6.2	6.2	6.9	6.9	6.9	7.7	7.7	7.7	8.5	8.5	8.5	9.4	9.4	9.4	Hi PR	261	262	264	302	303	305	345	346	348	392	393	394	442	443	445	495	496	498	Lo PR	120	123	130	126	129	136	131	134	141	135	138	145	138	142	149	143	147	154			
		MBh	25.6	26.0	26.7	24.8	25.1	25.8	23.5	23.8	24.6	21.8	22.2	22.9	20.4	20.8	21.4	18.8	19.1	19.7	0.78	0.71	0.57	0.79	0.72	0.58	0.82	0.74	0.61	0.82	0.74	0.61	1.01	0.79	0.66	1.01	0.85	0.71	ΔT	24	22	18	23	21	17	24	22	17	22	21	18	21	20	18	20	19	16	kW	1.55	1.55	1.54	1.72	1.72	1.72	1.91	1.91	1.91	2.11	2.11	2.11	2.33	2.33	2.33	2.59	2.59	2.59	Amps	5.5	5.5	5.5	6.2	6.2	6.2	7.0	7.0	7.0	7.7	7.7	7.7	8.5	8.5	8.5	9.5	9.5	9.5	Hi PR	263	265	266	305	306	308	348	349	351	394	395	397	444	445	447	498	499	501	Lo PR	122	125	132	128	131	138	133	136	143	137	140	147	140	144	151	145	149	156
		MBh	26.1	26.5	27.2	25.2	25.6	26.3	24.0	24.3	25.0	22.3	22.6	23.3	20.4	20.8	21.4	18.8	19.1	19.7	0.82	0.74	0.61	0.82	0.74	0.61	0.87	0.79	0.66	0.87	0.79	0.66	1.01	0.79	0.66	1.01	0.85	0.71	ΔT	24	22	18	23	21	17	24	22	17	22	21	18	21	20	18	20	19	16	kW	1.55	1.55	1.54	1.72	1.72	1.72	1.91	1.91	1.91	2.11	2.11	2.11	2.33	2.33	2.33	2.59	2.59	2.59	Amps	5.5	5.5	5.5	6.2	6.2	6.2	7.0	7.0	7.0	7.7	7.7	7.7	8.5	8.5	8.5	9.5	9.5	9.5	Hi PR	263	265	266	305	306	308	348	349	351	394	395	397	444	445	447	498	499	501	Lo PR	122	125	132	128	131	138	133	136	143	137	140	147	140	144	151	145	149	156
		MBh	26.1	26.5	27.2	25.2	25.6	26.3	24.0	24.3	25.0	22.3	22.6	23.3	20.4	20.8	21.4	18.8	19.1	19.7	0.82	0.74	0.61	0.82	0.74	0.61	0.87	0.79	0.66	0.87	0.79	0.66	1.01	0.79	0.66	1.01	0.85	0.71	ΔT	24	22	18	23	21	17	24	22	17	22	21	18	21	20	18	20	19	16	kW	1.55	1.55	1.54	1.72	1.72	1.72	1.91	1.91	1.91	2.11	2.11	2.11	2.33	2.33	2.33	2.59	2.59	2.59	Amps	5.5	5.5	5.5	6.2	6.2	6.2	7.0	7.0	7.0	7.7	7.7	7.7	8.5	8.5	8.5	9.5	9.5	9.5	Hi PR	263	265	266	305	306	308	348	349	351	394	395	397	444	445	447	498	499	501	Lo PR	122	125	132	128	131	138	133	136	143	137	140	147	140	144	151	145	149	156
		MBh	26.1	26.5	27.2	25.2	25.6	26.3	24.0	24.3	25.0	22.3	22.6	23.3	20.4	20.8	21.4	18.8	19.1	19.7	0.82	0.74	0.61	0.82	0.74	0.61	0.87	0.79	0.66	0.87	0.79	0.66	1.01	0.79	0.66	1.01	0.85	0.71	ΔT	24	22	18	23	21	17	24	22	17	22	21	18	21	20	18	20	19	16	kW	1.55	1.55	1.54	1.72	1.72	1.72	1.91	1.91	1.91	2.11	2.11	2.11	2.33	2.33	2.33	2.59	2.59	2.59	Amps	5.5	5.5	5.5	6.2	6.2	6.2	7.0	7.0	7.0	7.7	7.7	7.7	8.5	8.5	8.5	9.5	9.5	9.5	Hi PR	263	265	266	305	306	308	348	349	351	394	395	397	444	445	447	498	499	501	Lo PR	122	125	132	128	131	138	133	136	143	137	140	147	140	144	151	145	149	156
		MBh	26.1	26.5	27.2	25.2	25.6	26.3	24.0	24.3	25.0	22.3	22.6	23.3	20.4	20.8	21.4	18.8	19.1	19.7	0.82	0.74	0.61	0.83	0.75	0.62	0.87	0.79	0.66	0.87	0.79	0.66	1.01	0.83	0.69	1.01	0.89	0.75	ΔT	22	21	17	22	20	16	21	19	16	13	20	18	15	12	19	18	15	12	kW	1.56	1.56	1.55	1.73	1.73	1.73	1.92	1.92	1.92	2.12	2.12	2.12	2.34	2.34	2.34	2.60	2.60	2.60	Amps	5.6	5.6	5.6	6.3	6.3	6.2	7.0	7.0	7.0	7.8	7.8	7.7	8.6	8.6	8.6	9.5	9.5	9.5	Hi PR	266	267	269	307	308	310	350	351	353	397	398	400	447	448	450	500	502	503	Lo PR	124	128	134	130	134	141	135	139	146	139	143	150	143					



EXPANDED COOLING DATA — AXV9SA3610A\* / AHVE48DP1300A\*

IDB	AIRFLOW	OUTDOOR AMBIENT TEMPERATURE																							
		65°F				75°F				85°F				95°F				105°F				115°F			
		59	63	67	71	59	63	67	71	59	63	67	71	59	63	67	71	59	63	67	71	59	63	67	71
70	1070	MBh	40.3	40.8	42.0	38.5	39.0	40.2	36.1	36.6	37.7	33.1	33.6	34.6	29.8	30.3	31.4	26.9	27.4	28.4					
		S/T	0.61	0.53	0.39	0.62	0.54	0.40	0.64	0.56	0.42	0.66	0.59	0.45	0.69	0.61	0.47	0.74	0.66	0.52					
		ΔT	23	21	17	22	20	17	22	20	16	21	19	15	20	18	14	20	18	15					
		kW	2.22	2.22	2.22	2.52	2.52	2.51	2.85	2.85	2.84	3.21	3.21	3.20	3.62	3.61	3.61	4.09	4.09	4.08					
		Amps	6.2	6.2	6.1	7.7	7.7	7.7	9.7	9.6	9.6	12.0	12.0	12.0	15.0	15.0	15.0	18.7	18.7	18.6					
	1260	Hi PR	207	207	209	256	257	259	313	314	316	378	379	380	451	452	454	534	536	538					
		Lo PR	125	131	140	128	135	144	131	137	146	132	138	147	132	139	148	134	140	149					
		MBh	40.9	41.5	42.7	39.1	39.6	40.8	36.7	37.2	38.3	33.6	34.1	35.2	30.4	30.9	31.9	27.4	27.9	28.9					
		S/T	0.69	0.61	0.47	0.70	0.62	0.48	0.72	0.64	0.50	0.74	0.66	0.52	0.77	0.69	0.55	0.82	0.74	0.60					
		ΔT	22	20	16	21	19	15	20	18	15	19	17	14	18	17	13	19	17	14					
1450	kW	2.24	2.24	2.24	2.54	2.54	2.53	2.87	2.87	2.86	3.23	3.23	3.22	3.63	3.63	3.63	4.11	4.11	4.10						
	Amps	6.2	6.2	6.2	7.8	7.8	7.7	9.7	9.7	9.7	12.1	12.1	12.1	15.1	15.1	15.0	18.8	18.7	18.7						
	Hi PR	209	210	211	259	260	261	315	316	318	380	381	383	454	455	457	537	539	541						
	Lo PR	127	133	142	130	137	146	133	139	148	134	140	149	134	141	150	136	142	151						
	MBh	41.7	42.2	43.4	39.8	40.4	41.5	37.4	37.9	39.0	34.3	34.8	35.9	31.0	31.5	32.6	28.1	28.5	29.5						

75	1070	MBh	40.3	40.9	42.1	43.9	38.5	39.0	40.2	42.0	36.1	36.6	37.7	39.4	33.1	33.6	34.7	36.3	36.3	36.3									
		S/T	0.74	0.66	0.52	0.38	0.75	0.67	0.53	0.38	0.78	0.70	0.56	0.41	0.80	0.72	0.58	0.43	0.82	0.74	0.60								
		ΔT	28	26	22	18	27	25	21	17	26	24	21	17	25	23	20	16	24	22	19	15	24	22	19	15			
		kW	2.22	2.22	2.22	2.24	2.52	2.52	2.51	2.53	2.85	2.85	2.84	2.86	3.21	3.21	3.20	3.22	3.61	3.61	3.63	4.09	4.09	4.08	4.11	18.7	18.6	18.7	
		Amps	6.2	6.2	6.1	6.2	7.7	7.7	7.7	7.8	9.6	9.6	9.6	9.7	12.0	12.0	12.0	12.1	15.0	15.0	14.9	15.0	15.0	15.1	18.7	18.6	18.6		
	1260	Hi PR	207	208	209	213	257	258	259	263	313	314	316	320	378	379	381	385	452	453	455	535	536	538	543	540	541	543	
		Lo PR	125	131	140	152	128	135	144	156	131	137	146	158	132	138	147	159	132	139	148	159	134	140	149	160	138	144	153
		MBh	40.9	41.5	42.7	44.5	39.1	39.7	40.8	42.6	36.7	37.2	38.3	40.0	33.6	<b>34.1</b>	35.2	36.9	30.4	30.9	31.9	33.5	27.5	27.9	28.9	28.9	28.4	29.9	
		S/T	0.82	0.74	0.60	0.46	0.83	0.75	0.61	0.46	0.86	0.78	0.64	0.49	1.00	<b>0.80</b>	0.66	0.51	1.00	0.82	0.68	0.53	1.00	0.88	0.73	0.60	0.66	0.51	
		ΔT	26	24	20	16	25	23	20	16	25	23	19	15	24	<b>22</b>	18	14	22	21	17	14	23	21	18	14	14	15	
1450	kW	2.24	2.24	2.23	2.26	2.54	2.53	2.53	2.55	2.87	2.87	2.86	2.88	3.23	<b>3.23</b>	3.22	3.24	3.63	3.63	3.63	3.65	4.11	4.11	4.10	2.76	18.7	18.7	11.9	
	Amps	6.2	6.2	6.2	6.2	7.8	7.8	7.7	7.8	9.7	9.7	9.7	9.8	12.1	<b>12.1</b>	12.1	12.2	15.1	15.0	15.0	15.1	18.7	18.7	18.7	11.9	11.9	11.9		
	Hi PR	209	210	211	215	259	260	261	265	316	317	318	322	380	<b>382</b>	383	388	454	455	457	462	538	539	541	539	540	542	543	
	Lo PR	127	133	142	154	130	137	146	158	133	139	148	160	134	<b>140</b>	149	161	134	141	150	161	136	142	151	165	138	144	153	
	MBh	41.7	42.3	43.5	45.3	39.9	40.4	41.6	43.3	37.4	37.9	39.0	40.8	34.3	34.8	35.9	37.6	31.1	31.5	32.6	34.2	28.1	28.6	28.1	29.5	28.4	29.9		

IDB = Entering Indoor Dry Bulb Temperature  
 High and low pressures are measured at the liquid and suction service valves.  
 Airflow may vary depending on actual ambient conditions and system operation modes.  
 Shaded area is ACCA (TVA) conditions  
 kW = Total system power  
 Amps = outdoor unit amps (comp.+fan)

EXPANDED COOLING DATA — AXV9SA3610A\* / AHVE48DP1300A\*

IDB	AIRFLOW	OUTDOOR AMBIENT TEMPERATURE												105°F												115°F											
		65°F						75°F						85°F						95°F						105°F						115°F					
		59	63	67	71	75	79	59	63	67	71	75	79	59	63	67	71	75	79	59	63	67	71	75	79	59	63	67	71	75	79	59	63	67	71	75	79
80	MBh	40.5	41.1	42.3	44.1	38.7	39.3	40.4	42.2	36.3	36.8	37.9	39.6	33.3	33.8	34.9	36.5	30.0	30.5	31.6	33.1	27.1	27.6	28.6	30.1												
	S/T	0.99	0.79	0.65	0.51	0.99	0.80	0.66	0.51	1.00	0.83	0.69	0.54	1.00	0.85	0.71	0.56	1.00	0.87	0.73	0.58	1.00	0.93	0.79	0.64												
	ΔT	33	30	27	22	31	29	26	22	31	29	25	21	29	27	24	20	28	26	23	19	28	26	23	19												
	kW	2.22	2.22	2.22	2.24	2.52	2.52	2.51	2.53	2.85	2.85	2.84	2.87	3.21	3.21	3.20	3.23	3.62	3.61	3.61	3.63	4.09	4.09	4.08	4.11												
	Amps	6.2	6.2	6.1	6.2	7.7	7.7	7.7	7.8	9.7	9.6	9.6	9.7	12.0	12.0	12.0	12.1	15.0	15.0	14.9	15.0	18.7	18.7	18.6	18.7												
	Hi PR	207	208	209	213	257	258	260	263	314	315	316	320	378	379	381	386	452	453	455	460	535	536	538	543												
	Lo PR	125	132	140	152	129	135	144	156	131	138	147	158	132	139	148	159	133	139	148	160	134	141	150	161												
	MBh	41.1	41.7	42.9	44.7	39.3	39.9	41.0	42.8	36.9	37.4	38.5	40.2	33.8	34.3	35.0	37.1	30.6	31.1	32.1	33.7	27.6	28.1	29.1	29.0												
	S/T	0.99	0.87	0.73	0.58	0.99	0.88	0.74	0.59	1.00	0.91	0.77	0.62	1.00	0.93	0.79	0.64	1.00	0.95	0.81	0.66	1.00	1.00	0.87	0.74												
	ΔT	31	29	25	21	30	28	24	20	29	27	23	20	28	26	22	19	26	25	21	18	27	25	21	18												
kW	2.24	2.24	2.23	2.26	2.54	2.54	2.53	2.55	2.87	2.87	2.86	2.88	3.23	3.23	3.23	3.24	3.63	3.63	3.63	3.65	4.11	4.11	4.10	2.76													
Amps	6.2	6.2	6.2	6.2	7.8	7.8	7.7	7.8	9.7	9.7	9.7	9.8	12.1	12.1	12.1	12.2	15.1	15.1	15.0	15.1	18.8	18.7	18.7	11.9													
Hi PR	209	210	212	215	259	260	262	266	316	317	319	323	381	382	386	397	455	456	458	462	538	539	541	540													
Lo PR	127	134	143	155	131	138	147	159	133	140	149	161	134	141	152	162	135	141	150	162	136	143	152	165													
MBh	41.9	42.5	43.7	45.5	40.1	40.6	41.8	43.5	37.6	38.1	39.2	40.9	34.5	35.0	36.1	37.7	31.2	31.7	32.8	34.3	28.3	28.7	28.2	29.7													
S/T	0.99	0.91	0.77	0.62	0.99	0.92	0.78	0.63	1.00	0.95	0.81	0.66	1.00	0.97	0.83	0.68	1.00	0.99	0.85	0.70	1.00	1.00	0.93	0.78													
ΔT	30	28	24	20	29	27	23	19	28	26	22	18	27	25	21	17	25	24	20	17	25	24	20	17													
kW	2.26	2.25	2.25	2.27	2.55	2.55	2.55	2.57	2.88	2.88	2.88	2.90	3.24	3.24	3.24	3.26	3.65	3.65	3.64	3.66	4.13	4.12	2.76	2.77													
Amps	6.2	6.2	6.2	6.3	7.8	7.8	7.8	7.8	9.8	9.8	9.7	9.8	12.2	12.2	12.1	12.2	15.1	15.1	15.1	15.2	18.8	18.8	11.9	11.9													
Hi PR	211	212	214	217	262	263	264	268	318	319	321	325	383	384	386	391	457	459	460	465	541	542	538	543													
Lo PR	130	136	145	158	133	140	149	161	136	142	151	163	136	143	152	164	137	144	153	164	138	145	156	168													

1070	MBh	41.2	41.8	43.0	44.8	39.4	39.9	41.1	42.8	36.9	37.4	38.6	40.3	33.9	34.4	35.5	37.1	30.6	31.1	32.1	33.7	27.7	28.1	29.1	29.1
	S/T	0.99	0.90	0.76	0.61	0.99	0.99	0.77	0.62	1.00	1.00	0.79	0.64	1.00	1.00	0.81	0.67	1.00	1.00	0.84	0.69	1.00	1.00	0.89	0.77
	ΔT	37	35	31	27	35	33	30	26	34	33	29	25	33	31	27	24	31	30	26	23	31	30	26	22
	kW	2.23	2.23	2.22	2.24	2.52	2.52	2.52	2.54	2.86	2.85	2.85	2.87	3.22	3.21	3.21	3.23	3.62	3.62	3.61	3.64	4.10	4.10	4.09	2.75
	Amps	6.2	6.2	6.2	6.2	7.7	7.7	7.7	7.8	9.7	9.7	9.6	9.7	12.1	12.0	12.0	12.1	15.0	15.0	15.0	15.1	18.7	18.7	18.7	11.8
	Hi PR	208	209	210	214	258	259	261	265	315	316	317	322	380	381	382	387	453	454	456	461	537	538	540	538
	Lo PR	127	134	142	154	131	137	146	158	133	140	149	160	134	141	149	161	134	141	150	162	136	143	151	165
	MBh	41.8	42.4	43.6	45.4	40.0	40.5	41.7	43.4	37.5	38.0	39.1	40.9	34.4	34.9	36.0	37.7	31.2	31.6	32.7	34.3	28.2	28.7	29.6	29.6
	S/T	0.99	0.99	0.84	0.69	0.99	0.99	0.84	0.70	1.00	1.00	0.87	0.72	1.00	1.00	0.89	0.74	1.00	1.00	0.92	0.77	1.00	1.00	0.97	0.85
	ΔT	30	29	25	22	30	28	25	21	29	28	24	21	28	27	23	20	28	26	23	19	28	26	23	20
kW	2.25	2.25	2.24	2.26	2.54	2.54	2.54	2.56	2.87	2.87	2.87	2.89	3.24	3.23	3.23	3.25	3.64	3.64	3.63	3.66	4.12	4.11	4.11	2.76	
Amps	6.2	6.2	6.2	6.2	7.8	7.8	7.8	7.8	9.7	9.7	9.7	9.8	12.1	12.1	12.1	12.2	15.1	15.1	15.1	15.2	18.8	18.8	18.7	11.9	
Hi PR	210	211	213	216	260	261	263	267	317	318	320	324	382	383	385	389	456	457	459	464	539	541	543	541	
Lo PR	133	140	149	162	135	142	151	163	135	142	151	163	134	141	149	161	132	139	147	159	131	137	146	157	
MBh	42.6	43.2	44.4	46.2	40.7	41.3	42.4	44.2	38.2	38.7	39.9	41.6	35.1	35.6	36.7	38.4	31.8	32.3	33.3	34.9	28.8	27.8	28.8	29.3	
S/T	0.99	0.99	0.88	0.73	0.99	0.99	0.88	0.74	1.00	1.00	0.91	0.76	1.00	1.00	0.93	0.78	1.00	1.00	0.96	0.81	1.00	1.00	0.97	0.91	
ΔT	34	32	28	24	33	31	27	23	32	30	26	22	30	28	25	21	29	27	24	20	29	26	23	20	
kW	2.26	2.26	2.26	2.28	2.56	2.56	2.55	2.57	2.89	2.89	2.88	2.90	3.25	3.25	3.24	3.27	3.66	3.65	3.65	3.67	4.13	2.76	2.76	2.61	
Amps	6.2	6.2	6.2	6.3	7.8	7.8	7.8	7.9	9.8	9.8	9.8	9.8	12.2	12.2	12.2	12.2	15.2	15.1	15.1	15.2	18.9	11.9	11.9	11.3	
Hi PR	212	213	215	218	263	264	265	269	320	321	322	326	385	386	387	392	459	460	462	466	542	537	539	540	
Lo PR	132	138	148	160	135	142	151	163	137	144	153	165	138	145	154	166	139	145	154	166	140	149	158	171	

IDB = Entering Indoor Dry Bulb Temperature  
 High and low pressures are measured at the liquid and suction service valves.  
 Airflow may vary depending on actual ambient conditions and system operation modes.  
 Shaded area is AHRI conditions  
 kW = Total system power  
 Amps = outdoor unit amps (comp.+fan)

EXPANDED COOLING DATA — AXV9SA4810A\* / AHVE60DP1300A\*

IDB	AIRFLOW	OUTDOOR AMBIENT TEMPERATURE												105°F												115°F											
		65°F						75°F						85°F						95°F						105°F						115°F					
		59	63	67	71	59	63	67	71	59	63	67	71	59	63	67	71	59	63	67	71	59	63	67	71	59	63	67	71	59	63	67	71				
70	1170	MBh	26.7	40.2	51.5	35.1	48.8	50.2	46.0	46.7	48.1	43.1	43.8	45.2	39.8	40.5	41.9	0.63	0.55	0.43	0.69	0.61	0.48	32.5	33.1	34.3	0.69	0.61	0.48	32.5	33.1	34.3					
		S/T	0.65	0.51	0.36	0.60	0.49	0.36	0.59	0.51	0.39	0.60	0.53	0.40	0.63	0.55	0.43	0.63	0.55	0.43	0.69	0.61	0.48	0.69	0.61	0.48	0.69	0.61	0.48	0.69	0.61	0.48					
		ΔT	21	21	16	22	19	15	21	19	15	20	18	15	20	18	14	20	18	14	22	20	16	22	20	16	22	20	16	22	20	16					
		kW	1.48	2.28	3.26	2.27	3.69	3.69	4.17	4.16	4.15	4.67	4.67	4.66	5.23	5.22	5.22	5.23	5.22	5.22	5.23	4.98	4.98	4.97	4.98	4.98	4.97	4.98	4.98	4.97	4.98	4.98	4.97				
		Amps	6.0	9.1	12.8	9.1	14.4	14.4	16.2	16.2	16.2	18.2	18.1	18.1	20.3	20.3	20.3	20.3	20.3	20.3	19.3	19.3	19.3	19.3	19.3	19.3	19.3	19.3	19.3	19.3	19.3	19.3	19.3				
		Hi PR	257	270	285	307	328	330	374	375	377	424	425	427	478	480	481	478	480	481	522	524	526	522	524	526	522	524	526	522	524	526	522				
	Lo PR	119	119	124	120	122	130	119	127	135	123	130	139	126	134	143	126	134	143	132	139	149	132	139	149	132	139	149	132	139	149	132					
	MBh	28.9	44.3	52.3	39.2	49.5	51.0	46.8	47.4	48.9	43.8	44.5	45.9	40.6	41.2	42.6	40.6	41.2	42.6	33.1	33.7	34.9	33.1	33.7	34.9	33.1	33.7	34.9	33.1	33.7	34.9	33.1					
	S/T	0.70	0.57	0.43	0.66	0.56	0.43	0.66	0.59	0.46	0.68	0.60	0.48	0.70	0.62	0.50	0.70	0.62	0.50	0.76	0.69	0.56	0.76	0.69	0.56	0.76	0.69	0.56	0.76	0.69	0.56	0.76					
	ΔT	20	19	14	21	18	14	19	18	14	19	17	14	18	16	13	18	16	13	21	19	15	21	19	15	21	19	15	21	19	15	21					
	kW	1.59	2.56	3.29	2.57	3.72	3.71	4.19	4.19	4.18	4.70	4.69	4.69	5.25	5.25	5.24	5.25	5.25	5.24	5.01	5.00	5.00	5.01	5.00	5.00	5.01	5.00	5.00	5.01	5.00	5.00	5.01					
	Amps	6.5	10.2	12.9	10.2	14.5	14.5	16.3	16.3	16.3	18.3	18.3	18.2	20.4	20.4	20.4	20.4	20.4	20.4	19.4	19.4	19.4	19.4	19.4	19.4	19.4	19.4	19.4	19.4	19.4	19.4	19.4					
Hi PR	261	277	288	314	331	333	377	378	380	427	428	430	481	482	484	481	482	484	525	526	528	525	526	528	525	526	528	525	526	528	525						
Lo PR	120	120	127	120	124	133	121	129	137	123	131	140	127	135	144	127	135	144	133	141	151	133	141	151	133	141	151	133	141	151	133						
MBh	33.3	51.7	53.2	45.5	50.4	51.9	47.7	48.4	49.8	44.8	45.4	46.8	41.4	42.1	43.5	41.4	42.1	43.5	33.9	34.5	35.7	33.9	34.5	35.7	33.9	34.5	35.7	33.9	34.5	35.7	33.9						
S/T	0.71	0.59	0.46	0.68	0.60	0.47	0.69	0.62	0.49	0.71	0.64	0.51	0.73	0.66	0.53	0.73	0.66	0.53	0.80	0.72	0.59	0.80	0.72	0.59	0.80	0.72	0.59	0.80	0.72	0.59	0.80						
ΔT	19	17	13	20	16	13	18	16	13	18	16	12	17	15	12	17	15	12	19	17	14	19	17	14	19	17	14	19	17	14	19						
kW	1.81	3.32	3.31	3.09	3.74	3.74	4.22	4.21	4.21	4.72	4.72	4.71	5.28	5.27	5.27	5.28	5.27	5.27	5.03	5.02	5.02	5.03	5.02	5.02	5.03	5.02	5.02	5.03	5.02	5.02	5.03						
Amps	7.4	13.0	13.0	12.1	14.6	14.6	16.4	16.4	16.4	18.4	18.3	18.3	20.5	20.5	20.5	20.5	20.5	20.5	19.5	19.5	19.4	19.5	19.5	19.4	19.5	19.5	19.4	19.5	19.5	19.4	19.5						
Hi PR	267	289	291	324	334	336	379	381	383	430	431	433	484	485	487	484	485	487	528	529	531	528	529	531	528	529	531	528	529	531	528						
Lo PR	120	120	129	119	126	135	123	131	140	123	131	140	127	135	147	127	135	147	135	144	153	135	144	153	135	144	153	135	144	153	135						

75	1170	MBh	26.7	40.2	51.5	35.1	48.8	50.2	46.0	46.7	48.1	43.1	43.8	45.2	39.9	40.5	41.9	0.73	0.65	0.53	0.81	0.74	0.61	0.81	0.74	0.61	0.81	0.74	0.61	0.81	0.74	0.61	
		S/T	0.79	0.64	0.48	0.73	0.61	0.48	0.71	0.64	0.51	0.80	0.73	0.60	0.82	0.75	0.62	0.82	0.75	0.62	1.00	0.81	0.68	1.00	0.81	0.68	1.00	0.81	0.68	1.00	0.81	0.68	
		ΔT	25	25	20	26	23	20	25	23	20	24	22	19	24	22	18	24	22	18	25	23	19	25	23	19	25	23	19	25	23	19	
		kW	1.48	2.27	3.26	2.27	3.69	3.68	4.16	4.16	4.15	4.67	4.66	4.65	5.22	5.22	5.21	5.22	5.22	5.21	4.98	4.98	4.97	4.98	4.98	4.97	4.98	4.98	4.97	4.98	4.98	4.97	
		Amps	6.0	9.1	12.8	9.1	14.4	14.4	16.2	16.2	16.2	18.1	18.1	18.1	20.3	20.3	20.3	20.3	20.3	20.3	19.3	19.3	19.3	19.3	19.3	19.3	19.3	19.3	19.3	19.3	19.3	19.3	19.3
		Hi PR	257	270	286	308	328	330	374	375	377	424	425	427	479	480	482	479	480	482	523	524	526	523	524	526	523	524	526	523	524	526	523
	Lo PR	119	119	124	120	122	130	119	127	135	123	130	139	126	134	143	126	134	143	132	139	149	132	139	149	132	139	149	132	139	149	132	
	MBh	28.9	44.3	52.3	39.2	49.5	51.0	46.8	47.5	48.9	43.9	44.5	45.9	40.6	41.2	42.6	40.6	41.2	42.6	33.1	33.7	34.9	33.1	33.7	34.9	33.1	33.7	34.9	33.1	33.7	34.9	33.1	
	S/T	0.84	0.70	0.55	0.79	0.68	0.56	0.78	0.71	0.58	0.80	0.73	0.60	0.82	0.75	0.62	0.82	0.75	0.62	1.00	0.81	0.68	1.00	0.81	0.68	1.00	0.81	0.68	1.00	0.81	0.68	1.00	
	ΔT	24	24	19	25	22	18	24	22	18	23	21	18	24	22	17	24	22	17	25	23	19	25	23	19	25	23	19	25	23	19	25	
	kW	1.58	2.56	3.29	2.57	3.72	3.71	4.19	4.19	4.18	4.69	4.68	4.68	5.25	5.25	5.24	5.25	5.25	5.24	5.00	5.00	5.00	5.00	5.00	5.00	5.00	5.00	5.00	5.00	5.00	5.00	5.00	
	Amps	6.5	10.2	12.9	10.2	14.5	14.5	16.3	16.3	16.3	18.3	18.2	18.2	20.4	20.4	20.4	20.4	20.4	20.4	19.4	19.4	19.4	19.4	19.4	19.4	19.4	19.4	19.4	19.4	19.4	19.4	19.5	
Hi PR	261	278	289	314	331	333	377	378	380	427	428	430	481	483	485	481	483	485	526	527	529	526	527	529	526	527	529	526	527	529	526		
Lo PR	120	120	127	120	124	133	121	129	137	123	131	140	127	135	145	127	135	145	133	141	151	133	141	151	133	141	151	133	141	151	133		
MBh	33.3	51.8	53.2	45.6	50.5	51.9	47.7	48.4	49.8	44.8	45.4	46.8	41.5	42.1	43.5	41.5	42.1	43.5	33.9	34.5	35.7	33.9	34.5	35.7	33.9	34.5	35.7	33.9	34.5	35.7	33.9		
S/T	0.84	0.71	0.59	0.81	0.72	0.59	0.81	0.74	0.61	0.83	0.76	0.63	0.85	0.78	0.65	0.85	0.78	0.65	1.00	0.85	0.72	1.00	0.85	0.72	1.00	0.85	0.72	1.00	0.85	0.72	1.00		
ΔT	24	21	17	24	21	17	22	21	17	22	20	16	22	20	16	22	20	16	24	22	18	24	22	18	24	22	18	24	22	18	24		
kW	1.81	3.32	3.31	3.09	3.74	3.73	4.21	4.21	4.20	4.72	4.71	4.71	5.27	5.27	5.26	5.27	5.27	5.26	5.02	5.02	5.01	5.02	5.01	5.01	5.02	5.01	5.01	5.02	5.01	5.01	5.02		
Amps	7.4	13.0	13.0	12.1	14.6	14.6	16.4	16.4	16.4	18.3	18.3	18.3	20.6	20.6	20.6	20.6	20.6	20.6	19.5	19.5	19.5	19.5	19.5	19.5	19.5	19.5	19.5	19.5	19.5	19.5	19.5		
Hi PR	267	289	291	324	334	336	380	381	383	430	431	433	484	485	487	484	485	487	528	529	531	528	529	531	528	529	531	528	529	531	528		
Lo PR	120	120	129	120	126	135	123	131	140	123	131	140	127	135	147	127	135	147	135	144	153	135	144	153	135	144	153	135	144	153	135		

Shaded area is ACCA (TVA) conditions

IDB = Entering Indoor Dry Bulb Temperature  
High and low pressures are measured at the liquid and suction service valves.  
Airflow may vary depending on actual ambient conditions and system operation modes.

kW = Total system power  
Amps = outdoor unit amps (comp.+fan)

EXPANDED COOLING DATA — AXV9SA4810A\* / AHVE60DP1300A\*

IDB		OUTDOOR AMBIENT TEMPERATURE												105°F												115°F															
		65°F						75°F						85°F						95°F						105°F						115°F									
		59	63	67	71	75	79	59	63	67	71	75	79	59	63	67	71	75	79	59	63	67	71	75	79	59	63	67	71	75	79	59	63	67	71	75	79				
		AIRFLOW												ENTERING INDOOR WET BULB TEMPERATURE												ENTERING INDOOR WET BULB TEMPERATURE															
80	MBh	26.9	40.4	51.8	54.0	54.0	36.6	49.0	50.5	52.7	52.7	46.3	47.0	48.4	50.6	43.4	44.1	45.5	47.6	47.6	40.1	40.8	42.1	44.2	44.2	32.7	33.3	34.5	36.3												
	S/T	0.92	0.76	0.60	0.46	0.46	0.84	0.73	0.60	0.47	0.47	0.83	0.75	0.63	0.49	1.00	0.77	0.64	0.51	0.51	1.00	0.79	0.67	0.53	0.53	1.00	0.86	0.73	0.59												
	ΔT	29	30	24	21	21	31	28	24	20	20	29	27	24	20	28	27	23	20	20	28	26	22	19	19	31	29	25	21												
	kW	1.48	2.28	3.26	3.30	3.30	2.37	3.69	3.69	3.72	3.72	4.17	4.16	4.15	4.19	4.67	4.66	4.66	4.69	4.69	5.23	5.23	5.22	5.25	5.25	4.98	4.98	4.97	5.00												
	Amps	6.0	9.1	12.8	12.9	13.0	9.5	14.4	14.4	14.5	14.5	16.2	16.2	16.2	16.3	18.2	18.1	18.1	18.2	18.2	20.3	20.3	20.3	20.4	20.4	19.3	19.3	19.3	19.4												
	Hi PR	258	271	286	291	291	310	329	331	336	336	374	376	378	383	425	426	428	433	433	479	480	480	482	487	523	524	524	531												
	Lo PR	120	120	125	136	136	119	122	131	142	142	120	127	136	147	123	131	140	151	151	127	134	143	155	155	132	140	149	161												
	MBh	29.1	46.7	52.5	54.8	54.8	41.0	49.8	51.2	53.5	53.5	47.0	47.7	49.1	51.3	44.1	44.8	46.5	48.3	48.3	40.8	41.5	42.9	45.0	45.0	33.4	33.9	35.1	36.9												
	S/T	0.97	0.81	0.67	0.53	0.53	0.90	0.80	0.67	0.54	0.54	0.90	0.83	0.70	0.56	1.00	0.84	0.72	0.58	0.58	1.00	0.86	0.74	0.60	0.60	1.00	0.93	0.80	0.66												
	ΔT	29	29	23	19	19	30	26	22	19	19	28	26	22	19	27	25	22	18	18	26	24	21	18	18	29	27	24	20												
kW	1.59	2.73	3.29	3.32	3.32	2.71	3.72	3.71	3.75	3.75	4.19	4.19	4.18	4.22	4.70	4.69	4.65	4.72	4.72	5.25	5.25	5.24	5.28	5.28	5.01	5.00	5.00	5.02													
Amps	6.5	10.8	12.9	13.0	13.0	10.7	14.5	14.5	14.6	14.6	16.3	16.3	16.3	16.4	18.3	18.3	18.3	18.4	18.4	20.4	20.4	20.4	20.5	20.5	19.4	19.4	19.4	19.5													
Hi PR	262	280	289	294	294	317	332	334	339	339	377	379	381	385	428	429	428	436	436	482	483	485	490	490	526	527	529	534													
Lo PR	120	119	127	138	138	120	124	133	144	144	122	129	138	149	125	133	143	153	153	129	136	146	157	157	134	142	151	163													
MBh	35.7	52.0	53.5	55.7	55.7	50.0	50.7	52.2	54.4	54.4	48.0	48.6	50.1	52.2	45.0	45.7	47.1	49.2	49.2	41.7	42.4	43.7	45.8	45.8	34.1	34.7	35.9	37.7													
S/T	0.96	0.83	0.70	0.57	0.57	0.91	0.84	0.71	0.57	0.57	1.00	0.86	0.73	0.60	1.00	0.88	0.75	0.62	0.62	1.00	0.90	0.77	0.64	0.64	1.00	0.97	0.84	0.70													
ΔT	28	25	22	18	18	27	25	21	18	18	27	25	21	18	26	24	21	17	17	25	23	20	16	16	28	26	22	19													
kW	1.94	3.32	3.31	3.35	3.35	3.75	3.74	3.74	3.77	3.77	4.22	4.21	4.20	4.24	4.72	4.71	4.71	4.74	4.74	5.28	5.27	5.27	5.30	5.30	5.02	5.02	5.02	5.04													
Amps	7.9	13.0	13.0	13.1	13.1	14.6	14.6	14.6	14.7	14.7	16.4	16.4	16.4	16.5	18.4	18.3	18.3	18.4	18.4	20.5	20.5	20.5	20.6	20.6	19.5	19.5	19.4	19.5													
Hi PR	270	290	292	297	297	333	335	337	341	341	380	381	383	388	430	432	434	439	439	485	486	488	493	493	529	530	532	537													
Lo PR	119	121	129	140	140	119	127	135	146	146	124	131	140	151	127	135	144	155	155	131	139	148	159	159	136	144	154	165													
MBh	29.1	44.6	52.6	54.9	54.9	41.0	49.9	51.3	53.5	53.5	47.1	47.8	49.2	51.4	44.2	44.8	46.2	48.4	48.4	40.9	41.5	42.9	45.0	45.0	33.4	34.0	35.2	37.0													
S/T	1.00	0.85	0.69	0.56	0.56	1.00	0.83	0.70	0.56	0.56	1.00	0.85	0.72	0.59	1.00	0.87	0.74	0.61	0.61	1.00	0.90	0.76	0.63	0.63	1.00	0.90	0.83	0.69													
ΔT	34	34	28	24	24	35	31	28	24	24	33	31	27	24	32	30	27	23	23	31	29	26	22	22	34	32	29	25													
kW	1.58	2.55	3.27	3.31	3.31	2.69	3.70	3.69	3.73	3.73	4.17	4.17	4.16	4.20	4.68	4.67	4.67	4.70	4.70	5.23	5.23	5.22	5.26	5.26	4.99	4.99	4.98	5.01													
Amps	6.4	10.1	12.8	12.9	13.1	10.7	14.4	14.4	14.6	14.6	16.3	16.2	16.2	16.3	18.2	18.2	18.1	18.3	18.3	20.3	20.3	20.3	20.4	20.4	19.3	19.3	19.3	19.4													
Hi PR	260	277	288	292	292	315	330	332	337	337	376	377	379	384	426	427	429	434	434	480	482	484	489	489	525	526	528	532													
Lo PR	120	120	127	137	137	119	124	133	144	144	121	129	138	149	125	133	142	153	153	128	136	145	156	156	134	142	151	162													
MBh	33.4	51.9	53.4	55.6	55.6	45.7	50.6	52.1	54.3	54.3	47.8	48.5	49.9	52.1	44.9	45.6	47.0	49.1	49.1	41.6	42.2	43.6	45.7	45.7	34.0	34.6	35.8	37.6													
S/T	1.00	0.89	0.76	0.63	0.63	1.00	0.90	0.77	0.63	0.63	1.00	0.92	0.79	0.66	1.00	0.94	0.81	0.68	0.68	1.00	0.90	0.83	0.70	0.70	1.00	0.90	0.90	0.76													
ΔT	33	30	27	23	23	34	30	26	23	23	31	30	26	22	31	29	25	22	22	30	28	25	21	21	33	31	27	24													
kW	1.80	3.31	3.30	3.33	3.33	3.08	3.73	3.72	3.76	3.76	4.20	4.20	4.19	4.22	4.70	4.70	4.69	4.73	4.73	5.26	5.26	5.25	5.28	5.28	5.01	5.01	5.00	5.03													
Amps	7.3	13.0	12.9	13.1	13.1	12.1	14.6	14.5	14.7	14.7	16.4	16.4	16.3	16.5	18.3	18.3	18.3	18.4	18.4	20.5	20.4	20.4	20.5	20.5	19.4	19.4	19.4	19.5													
Hi PR	267	288	290	295	295	323	333	335	340	340	379	380	382	387	429	430	432	437	437	483	485	486	491	491	527	529	530	535													
Lo PR	120	123	131	142	142	121	128	137	148	148	125	133	142	153	129	137	146	157	157	132	140	150	161	161	137	146	155	167													
MBh	39.5	52.8	54.3	56.6	56.6	50.9	51.5	53.0	55.2	55.2	48.8	49.4	50.9	53.0	45.8	46.5	47.9	50.0	50.0	42.5	43.1	44.5	46.6	46.6	34.8	35.4	36.6	38.4													
S/T	1.00	0.93	0.80	0.66	0.66	1.00	0.93	0.80	0.67	0.67	1.00	0.96	0.83	0.69	1.00	0.90	0.85	0.71	0.71	1.00	0.90	0.87	0.73	0.73	1.00	0.94	0.80	0.80													
ΔT	33	29	26	22	22	31	29	25	21	21	30	28	25	21	30	28	24	21	21	29	27	24	20	20	32	30	26	22													
kW	2.15	3.33	3.32	3.36	3.36	3.76	3.75	3.74	3.78	3.78	4.22	4.22	4.21	4.25	4.73	4.72	4.72	4.75	4.75	5.28	5.28	5.27	5.31	5.31	5.03	5.03	5.02	5.05													
Amps	8.7	13.0	13.0	13.2	13.2	14.7	14.7	14.6	14.8	14.8	16.5	16.4	16.4	16.6	18.4	18.4	18.3	18.5	18.5	20.5	20.5	20.5	20.6	20.6	19.5	19.5	19.5	19.6													
Hi PR	274	291	293	298	298	335	336	338	343	343	381	383	385	390	432	433	435	440	440	486	487	489	494	494	530	531	533	538													
Lo PR	120	123	131	142	142	121	128	137	148	148	125	133	142	153	129	137	146	157	157	132	140	150	161	161	137	146	155	167													

IDB = Entering Indoor Dry Bulb Temperature  
 High and low pressures are measured at the liquid and suction service valves.  
 Airflow may vary depending on actual ambient conditions and system operation modes.  
 Shaded area is AHRF conditions  
 kW = Total system power  
 Amps = outdoor unit amps (comp.+fan)

EXPANDED COOLING DATA — AXV9SA6010A\* / AHVE60DP1300A\*

IDB	AIRFLOW	OUTDOOR AMBIENT TEMPERATURE																							
		65°F				75°F				85°F				95°F				105°F				115°F			
		59	63	67	71	59	63	67	71	59	63	67	71	59	63	67	71	59	63	67	71	59	63	67	71
<b>70</b>	MBh	36.4	43.9	53.4	45.4	52.0	58.5	53.4	56.0	57.7	53.2	54.0	55.7	50.5	51.4	53.1	44.0	44.8	44.4						
	S/T	0.65	0.53	0.37	0.61	0.51	0.36	0.60	0.51	0.38	0.59	0.52	0.40	0.61	0.54	0.42	0.69	0.61	0.49						
	ΔT	20	19	16	21	19	16	22	20	16	21	20	16	21	19	15	21	19	16						
	kW	1.94	2.46	3.17	2.95	3.56	4.54	4.39	5.10	5.09	5.69	5.68	5.67	6.33	6.33	6.32	5.52	5.52	5.11						
	Amps	7.7	9.5	11.9	11.4	13.5	17.0	16.7	19.4	19.4	22.0	22.0	22.0	25.0	24.9	24.9	22.1	22.1	20.5						
	Hi PR	249	260	272	305	314	318	366	363	365	413	414	416	469	470	472	527	528	524						
Lo PR	120	119	121	120	120	122	119	120	127	122	124	130	124	127	134	133	136	145							
<b>70</b>	MBh	40.6	46.7	59.8	49.8	55.9	59.4	56.6	56.8	58.6	54.1	54.9	56.6	51.4	52.3	54.0	42.9	43.6	45.2						
	S/T	0.71	0.60	0.44	0.67	0.58	0.43	0.66	0.58	0.45	0.66	0.59	0.47	0.68	0.61	0.49	0.77	0.69	0.56						
	ΔT	19	18	15	20	18	15	20	19	15	20	18	14	19	18	14	19	18	14						
	kW	2.22	2.66	3.81	3.34	3.94	4.57	4.80	5.13	5.12	5.72	5.72	5.71	6.37	6.36	6.35	5.15	5.14	5.14						
	Amps	8.7	10.1	14.1	12.7	14.8	17.1	18.3	19.5	19.5	22.2	22.1	22.1	25.1	25.1	25.0	20.6	20.6	20.6						
	Hi PR	258	265	282	313	322	321	373	366	368	416	417	419	472	473	475	524	525	527						
Lo PR	120	120	119	120	120	124	120	122	129	122	126	132	126	129	136	136	140	147							
<b>1890</b>	MBh	44.8	51.3	60.3	53.0	58.8	60.5	57.1	58.0	59.7	55.2	56.0	57.7	52.6	53.4	55.2	43.9	44.6	42.8						
	S/T	0.73	0.63	0.46	0.70	0.59	0.47	0.68	0.61	0.49	0.70	0.63	0.50	0.72	0.65	0.52	0.81	0.73	0.61						
	ΔT	18	17	14	19	17	14	19	17	14	19	17	13	18	16	13	18	17	13						
	kW	2.50	3.01	4.10	3.61	4.61	4.60	5.16	5.16	5.15	5.75	5.74	5.73	6.39	6.39	6.38	5.17	5.16	4.57						
	Amps	9.6	11.3	15.1	13.7	17.2	17.2	19.7	19.6	19.6	22.3	22.3	22.2	25.2	25.2	25.2	20.7	20.7	18.3						
	Hi PR	264	273	279	319	321	323	368	369	371	419	420	422	475	476	478	526	528	521						
Lo PR	120	120	121	121	120	126	121	124	131	124	128	134	128	131	138	138	142	152							

<b>1390</b>	MBh	36.4	43.9	53.4	45.4	52.0	58.5	53.4	56.0	57.7	53.2	54.0	55.8	58.4	50.6	51.4	53.2	44.1	44.8	44.4	
	S/T	0.79	0.67	0.50	0.74	0.64	0.48	0.72	0.63	0.50	0.71	0.64	0.52	0.73	0.66	0.54	0.40	0.81	0.74	0.61	
	ΔT	24	23	21	25	24	21	26	25	21	26	24	20	26	24	20	16	25	23	20	
	kW	1.94	2.46	3.17	2.95	3.56	4.53	4.38	5.09	5.08	5.12	5.68	5.68	5.67	5.71	6.33	6.33	6.36	5.52	5.51	5.11
	Amps	7.6	9.5	11.9	11.4	13.5	16.9	16.7	19.4	19.3	19.5	22.0	22.0	22.0	22.1	24.9	24.9	25.1	22.1	22.1	20.5
	Hi PR	250	260	272	305	315	318	366	363	365	370	414	415	417	421	469	470	472	527	528	524
Lo PR	120	119	121	120	120	122	119	121	127	137	121	124	130	140	124	127	134	133	136	145	
<b>1640</b>	MBh	40.6	46.7	59.8	49.8	55.9	59.4	56.6	56.9	58.6	54.1	54.9	56.6	59.3	51.5	52.3	54.1	42.9	43.7	45.2	
	S/T	0.84	0.73	0.56	0.80	0.70	0.55	0.79	0.70	0.57	0.78	0.71	0.59	0.80	0.73	0.60	0.47	0.99	0.82	0.69	
	ΔT	23	22	19	24	23	19	25	23	19	24	22	19	24	22	18	14	23	22	18	
	kW	2.22	2.66	3.81	3.34	3.94	4.57	4.80	5.13	5.12	5.16	5.72	5.70	5.74	6.36	6.36	6.35	5.15	5.14	5.14	
	Amps	8.6	10.1	14.1	12.7	14.8	17.1	18.3	19.5	19.5	19.7	22.2	22.1	22.3	25.1	25.1	25.0	20.6	20.6	20.6	
	Hi PR	258	266	282	313	322	321	373	366	368	373	416	420	424	472	473	475	524	525	527	
Lo PR	120	120	119	120	120	124	120	122	134	131	122	126	132	142	126	129	136	136	140	147	
<b>1890</b>	MBh	44.8	51.3	60.3	53.1	58.8	60.5	57.2	58.0	59.7	55.2	56.0	57.8	60.4	52.6	53.4	55.2	43.9	44.7	42.9	
	S/T	0.86	0.76	0.58	0.82	0.71	0.59	0.81	0.73	0.61	0.82	0.75	0.62	0.83	0.76	0.64	0.51	0.99	0.86	0.74	
	ΔT	23	21	18	23	22	18	24	22	18	23	21	18	23	21	17	13	22	21	17	
	kW	2.50	3.00	4.09	3.61	4.60	4.59	5.16	5.15	5.14	5.19	5.74	5.73	5.77	6.39	6.39	6.38	5.16	5.16	4.56	
	Amps	9.6	11.3	15.1	13.7	17.2	17.2	19.7	19.6	19.6	19.8	22.3	22.2	22.4	25.2	25.2	25.1	20.7	20.7	18.3	
	Hi PR	265	273	279	319	322	324	368	369	371	376	419	420	422	427	475	476	478	527	528	521
Lo PR	120	120	121	121	120	126	121	125	131	141	125	128	134	144	128	131	138	138	142	152	

IDB = Entering Indoor Dry Bulb Temperature  
 High and low pressures are measured at the liquid and suction service valves.  
 Airflow may vary depending on actual ambient conditions and system operation modes.  
 Shaded area is ACCA (TVA) conditions  
 kW = Total system power  
 Amps = outdoor unit amps (comp. + fan)

EXPANDED COOLING DATA — AXV9SA6010A\* / AHVE60DP1300A\*

IDB	AIRFLOW	OUTDOOR AMBIENT TEMPERATURE																							
		65°F				75°F				85°F				95°F				105°F				115°F			
		59	63	67	71	59	63	67	71	59	63	67	71	59	63	67	71	59	63	67	71	59	63	67	71
<b>80</b>	MBh	39.2	44.1	56.8	61.2	45.7	52.3	58.8	61.4	53.7	56.3	58.0	60.6	53.5	54.3	56.1	58.7	50.9	51.7	53.5	56.1	44.3	45.1	44.7	43.6
	S/T	0.90	0.80	0.62	0.46	0.86	0.76	0.60	0.46	0.84	0.75	0.62	0.49	0.83	0.76	0.63	0.50	0.99	0.78	0.65	0.52	0.99	0.86	0.74	0.61
	ΔT	29	28	25	22	29	28	25	21	30	29	25	21	30	28	25	21	29	28	24	20	29	27	24	20
	kW	2.13	2.46	3.48	4.08	2.95	3.56	4.53	4.58	4.39	5.09	5.09	5.13	5.69	5.68	5.67	5.71	6.33	6.33	6.32	6.36	5.52	5.52	5.11	4.55
	Amps	8.3	9.5	12.9	15.0	11.4	13.5	17.0	17.1	16.7	19.4	19.4	19.5	22.0	22.0	22.0	22.1	24.9	24.9	24.9	25.1	22.1	22.1	20.5	18.3
	Hi PR	254	261	277	279	306	315	319	323	366	364	366	371	414	415	417	422	470	471	473	478	527	528	525	521
	Lo PR	119	120	119	127	121	121	123	132	120	121	127	137	121	124	131	141	124	128	134	144	133	137	145	159
	MBh	43.0	46.9	60.1	62.1	52.3	56.2	59.7	62.3	56.4	57.2	58.9	61.5	54.4	55.2	<b>57.0</b>	59.6	51.8	52.6	54.4	57.0	43.2	43.9	45.5	44.4
	S/T	0.96	0.86	0.68	0.53	0.91	0.82	0.67	0.54	0.89	0.82	0.69	0.56	1.00	0.83	<b>0.70</b>	0.57	0.99	0.85	0.72	0.59	0.99	0.94	0.81	0.69
	ΔT	28	26	24	20	29	27	24	20	29	27	24	20	29	27	<b>23</b>	19	28	26	22	19	28	26	22	18
kW	2.39	2.66	3.81	4.11	3.59	3.94	4.57	4.61	5.13	5.13	5.12	5.16	5.72	5.72	<b>5.70</b>	5.75	6.37	6.36	6.35	6.39	5.15	5.14	5.14	4.57	
Amps	9.2	10.1	14.1	15.1	13.6	14.8	17.1	17.3	19.5	19.5	19.5	19.7	22.2	22.1	<b>22.1</b>	22.3	25.1	25.1	25.0	25.2	20.6	20.6	20.6	18.4	
Hi PR	261	266	283	281	317	323	321	326	366	367	369	373	417	418	<b>420</b>	425	473	474	476	481	524	526	528	524	
Lo PR	119	121	120	129	119	121	125	134	119	123	129	139	123	126	<b>133</b>	143	126	130	136	146	137	141	147	161	
MBh	47.2	53.9	60.6	63.2	56.5	59.1	60.8	63.4	57.5	58.3	60.0	62.6	55.5	56.3	58.1	60.7	52.9	53.7	55.5	58.2	44.2	44.9	43.1	45.3	
S/T	0.98	0.87	0.70	0.57	0.93	0.83	0.71	0.57	0.92	0.85	0.72	0.59	1.00	0.86	0.74	0.61	0.99	0.88	0.76	0.62	0.99	0.98	0.87	0.72	
ΔT	27	26	23	19	28	26	23	19	28	26	23	19	28	26	22	18	27	25	21	18	26	25	21	17	
kW	2.68	3.23	4.10	4.14	3.97	4.61	4.60	4.64	5.16	5.16	5.15	5.19	5.75	5.74	5.73	5.77	6.39	6.39	6.38	6.42	5.17	5.16	4.57	4.59	
Amps	10.2	12.1	15.1	15.3	14.9	17.2	17.2	17.4	19.7	19.6	19.6	19.8	22.3	22.3	22.2	22.4	25.2	25.2	25.1	25.3	20.7	20.7	18.3	18.4	
Hi PR	268	276	279	284	324	322	324	329	368	369	371	376	420	421	423	428	475	477	479	483	527	528	522	526	
Lo PR	120	119	121	131	119	121	127	137	122	125	131	141	125	128	135	145	128	132	138	148	139	143	152	163	

<b>85</b>	MBh	40.9	47.0	60.2	62.2	50.1	56.2	59.8	62.4	56.4	57.3	59.0	61.6	54.5	55.3	57.0	59.7	51.9	52.7	54.4	57.1	45.3	44.0	45.5	44.4
	S/T	1.00	0.89	0.71	0.56	1.00	0.85	0.69	0.56	1.00	0.84	0.71	0.58	1.00	0.85	0.73	0.60	0.99	0.87	0.74	0.61	0.99	0.99	0.83	0.71
	ΔT	33	32	29	26	34	32	29	25	35	33	29	25	34	32	28	25	33	31	28	24	33	31	27	23
	kW	2.21	2.64	3.79	4.09	3.33	3.92	4.54	4.59	5.11	5.10	5.10	5.14	5.70	5.69	5.68	5.72	6.34	6.34	6.33	6.37	5.53	5.13	5.12	4.56
	Amps	8.6	10.1	14.0	15.0	12.7	14.8	17.0	17.2	19.5	19.4	19.4	19.6	22.1	22.0	22.0	22.2	25.0	25.0	24.9	25.1	22.1	20.6	20.5	18.3
	Hi PR	257	265	281	280	312	321	320	325	364	365	367	372	415	417	418	423	471	472	474	479	529	524	526	522
	Lo PR	120	120	119	128	120	120	124	134	119	123	129	139	123	126	132	142	126	129	136	146	135	140	147	161
	MBh	44.9	51.4	60.5	63.0	53.2	59.0	60.7	63.3	57.3	58.1	59.9	62.5	55.4	56.2	57.9	60.6	52.8	53.6	55.4	58.0	44.1	44.8	46.3	45.2
	S/T	1.00	0.94	0.76	0.63	1.00	0.89	0.76	0.63	1.00	0.91	0.78	0.65	1.00	0.92	0.80	0.67	0.99	0.94	0.81	0.68	0.99	0.99	0.91	0.79
	ΔT	32	31	28	24	33	32	28	24	33	31	28	24	33	31	27	23	32	30	26	23	31	29	26	22
kW	2.49	2.99	4.08	4.12	3.60	4.59	4.58	4.62	5.14	5.14	5.13	5.17	5.73	5.73	5.72	5.76	6.38	6.37	6.36	6.40	5.15	5.15	5.14	4.58	
Amps	9.6	11.3	15.0	15.2	13.7	17.2	17.1	17.3	19.6	19.6	19.5	19.7	22.2	22.2	22.1	22.3	25.1	25.1	25.1	25.2	20.7	20.7	20.6	18.4	
Hi PR	264	272	278	283	318	321	323	327	367	368	370	375	418	419	421	426	474	475	477	482	526	527	529	525	
Lo PR	120	120	121	130	121	120	126	136	121	124	131	141	124	128	134	144	128	131	138	148	138	142	149	163	
MBh	47.9	54.8	61.6	64.1	59.9	60.1	61.8	64.3	58.4	59.3	61.0	63.6	56.5	57.3	59.0	61.7	53.9	54.7	56.5	59.2	45.1	42.5	43.9	46.1	
S/T	1.00	0.97	0.80	0.66	1.00	0.93	0.80	0.67	1.00	0.95	0.82	0.69	1.00	0.96	0.83	0.70	0.99	0.97	0.85	0.72	0.99	0.99	0.97	0.82	
ΔT	31	30	27	23	32	30	27	23	32	30	26	23	31	29	26	22	31	29	25	21	30	28	24	21	
kW	2.69	3.23	4.11	4.15	4.33	4.62	4.61	4.65	5.17	5.17	5.16	5.20	5.76	5.75	5.74	5.78	6.40	6.40	6.39	6.43	5.17	4.58	4.57	4.60	
Amps	10.3	12.1	15.1	15.3	16.2	17.3	17.3	17.4	19.7	19.7	19.6	19.8	22.3	22.3	22.3	22.4	25.2	25.2	25.2	25.4	20.7	18.4	18.4	18.5	
Hi PR	269	277	281	285	329	323	325	330	370	371	373	377	421	422	424	429	477	478	480	485	528	521	523	528	
Lo PR	121	121	123	133	119	122	128	138	123	127	133	143	127	130	137	147	130	133	140	150	141	147	154	165	

IDB = Entering Indoor Dry Bulb Temperature  
 High and low pressures are measured at the liquid and suction service valves.  
 Airflow may vary depending on actual ambient conditions and system operation modes.  
 Shaded area is AHRI conditions  
 kW = Total system power  
 Amps = outdoor unit amps (comp.-fian)

PERFORMANCE DATA FOR STANDARD OPERATING MODE

AXV9SA2410A* / AHVE36CP1300A*				
DESIGN SUBCOOLING @ AHRI 95 °F CONDITIONS, 13-15 °F - 100 % DEMAND				
OUTDOOR TEMP. °F	TOTAL BTU/H	SENSIBLE BTU/H	LATENT BTU/H	TOTAL WATTS
75°	26,000	18,500	7,500	1,720
80°	25,400	18,300	7,100	1,815
85°	24,700	18,000	6,700	1,910
90°	24,000	17,700	6,300	2,010
95°	23,200	17,400	5,800	2,110
100°	22,200	17,000	5,200	2,220
105°	21,100	16,500	4,600	2,330
110°	20,300	16,400	3,900	2,460
115°	19,400	16,300	3,100	2,590
TVA Conditions @ 95° OD DB, 75° ID, 63° ID WB				
95°	22,200	17,100	5,100	2,110

AXV9SA2410A* / AHVE36CP1300A*				
DESIGN SUBCOOLING @ AHRI 95 °F CONDITIONS, 13-15 °F - BOOST MODE				
OUTDOOR TEMP. °F	TOTAL BTU/H	SENSIBLE BTU/H	LATENT BTU/H	TOTAL WATTS
75°	33,600	22,200	11,400	2,200
80°	32,800	22,100	10,700	2,300
85°	31,900	22,000	9,900	2,450
90°	30,800	21,600	9,200	2,600
95°	29,700	21,100	8,600	2,700
100°	28,500	20,700	7,800	2,900
105°	27,300	20,200	7,100	3,000
110°	26,200	20,000	6,200	3,200
115°	25,100	19,800	5,300	3,350
TVA Conditions @ 95° OD DB, 75° ID, 63° ID WB				
95°	28,700	20,700	8,000	2,700

AXV9SA3610A* / AHVE48DP1300A*				
DESIGN SUBCOOLING @ AHRI 95 °F CONDITIONS, 8-10 °F - 100 % DEMAND				
OUTDOOR TEMP. °F	TOTAL BTU/H	SENSIBLE BTU/H	LATENT BTU/H	TOTAL WATTS
75°	41,000	30,300	10,700	2,530
80°	39,800	30,000	9,800	2,695
85°	38,500	29,600	8,900	2,860
90°	36,800	28,700	8,100	3,095
95°	35,000	27,700	7,300	3,330
100°	33,600	26,900	6,700	3,480
105°	32,100	26,000	6,100	3,630
110°	30,600	25,700	4,900	3,865
115°	29,100	25,300	3,800	4,100
TVA Conditions @ 95° OD DB, 75° ID, 63° ID WB				
95°	34,100	27,300	6,800	3,230

AXV9SA3610A* / AHVE48DP1300A*				
DESIGN SUBCOOLING @ AHRI 95 °F CONDITIONS, 8-10 °F - BOOST MODE				
OUTDOOR TEMP. °F	TOTAL BTU/H	SENSIBLE BTU/H	LATENT BTU/H	TOTAL WATTS
75°	59,100	38,400	20,700	3,600
80°	57,300	37,800	19,500	3,900
85°	55,500	37,200	18,300	4,150
90°	53,200	36,200	17,000	4,400
95°	50,900	35,100	15,800	4,700
100°	48,500	34,200	14,300	5,000
105°	46,100	33,200	12,900	5,350
110°	37,600	29,200	8,400	4,800
115°	29,000	25,200	3,800	4,200
TVA Conditions @ 95° OD DB, 75° ID, 63° ID WB				
95°	49,100	34,400	14,700	4,700

PERFORMANCE DATA FOR STANDARD OPERATING MODE (CONT.)

AXV9SA4810A* / AHVE60DP1300A*				
DESIGN SUBCOOLING @ AHRI 95 °F CONDITIONS, 8-10 °F				
- 100 % DEMAND				
OUTDOOR TEMP. °F	TOTAL BTU/H	SENSIBLE BTU/H	LATENT BTU/H	TOTAL WATTS
75°	51,200	34,300	16,900	3,710
80°	50,200	34,400	15,800	3,945
85°	49,100	34,400	14,700	4,180
90°	47,800	34,000	13,800	4,415
<b>95°</b>	<b>46,500</b>	<b>33,500</b>	<b>13,000</b>	<b>4,650</b>
100°	44,700	32,600	12,100	4,945
105°	42,900	31,700	11,200	5,240
110°	39,000	29,900	9,100	5,120
115°	35,100	28,100	7,000	5,000
TVA CONDITIONS @ 95° OD DB, 75° ID, 63° ID WB				
95°	44,500	32,500	12,000	4,690

AXV9SA4810A* / AHVE60DP1300A*				
DESIGN SUBCOOLING @ AHRI 95 °F CONDITIONS, 8-10 °F				
- BOOST MODE				
OUTDOOR TEMP. °F	TOTAL BTU/H	SENSIBLE BTU/H	LATENT BTU/H	TOTAL WATTS
75°	61,800	38,900	22,900	5,400
80°	61,200	38,900	22,300	5,850
85°	60,600	38,800	21,800	6,300
90°	58,800	38,300	20,500	6,800
<b>95°</b>	<b>55,900</b>	<b>37,500</b>	<b>18,400</b>	<b>6,850</b>
100°	50,100	35,800	14,300	6,250
105°	44,300	34,000	10,300	5,650
110°	39,700	31,000	8,700	5,300
115°	35,100	28,000	7,100	5,000
TVA CONDITIONS @ 95° OD DB, 75° ID, 63° ID WB				
95°	53,700	36,500	17,200	6,900

AXV9SA6010A* / AHVE60DP1300A*				
DESIGN SUBCOOLING @ AHRI 95 °F CONDITIONS, 15-17 °F				
- 100 % DEMAND				
OUTDOOR TEMP. °F	TOTAL BTU/H	SENSIBLE BTU/H	LATENT BTU/H	TOTAL WATTS
75°	59,700	40,000	19,700	4,570
80°	59,300	40,300	19,000	4,845
85°	58,900	40,600	18,300	5,120
90°	58,000	40,300	17,700	5,410
<b>95°</b>	<b>57,000</b>	<b>39,900</b>	<b>17,100</b>	<b>5,700</b>
100°	55,700	39,600	16,100	6,025
105°	54,400	39,200	15,200	6,350
110°	50,000	38,100	11,900	5,745
115°	45,500	36,900	8,600	5,140
TVA CONDITIONS @ 95° OD DB, 75° ID, 63° ID WB				
95°	54,900	39,000	15,900	5,710

AXV9SA6010A* / AHVE60DP1300A*				
DESIGN SUBCOOLING @ AHRI 95 °F CONDITIONS, 15-17 °F				
- BOOST MODE				
OUTDOOR TEMP. °F	TOTAL BTU/H	SENSIBLE BTU/H	LATENT BTU/H	TOTAL WATTS
75°	62,900	42,600	20,300	4,600
80°	62,600	43,000	19,600	4,900
85°	62,000	43,200	18,800	5,100
90°	61,100	43,100	18,000	5,400
<b>95°</b>	<b>60,000</b>	<b>43,100</b>	<b>16,900</b>	<b>6,000</b>
100°	58,600	43,700	14,900	6,700
105°	57,200	41,700	15,500	6,400
110°	53,600	40,400	13,200	6,300
115°	45,500	36,800	8,700	5,200
TVA CONDITIONS @ 95° OD DB, 75° ID, 63° ID WB				
95°	57,800	41,700	16,100	5,700

## SOUND POWER LEVELS

TONNAGE	TOTAL UNIT SOUND RATING (dBA)	OCTAVE BAND SPECTRUM FREQUENCY (Hz) ANALYSIS (DBs)						
		125	250	500	1000	2000	4000	8000
2-ton	67	57.9	58.4	62.9	61.1	55.1	48.3	41.2
3-ton	71	60.3	64.5	65.2	65.8	60.9	54.4	48.1
4-ton	73	62.9	66.4	67.0	67.4	63.0	58.9	50.6
5-ton	77	79.6	76.8	75.5	71.8	67.2	59.0	53.6

**Note:** Tested in accordance with AHRI Standard 270.

### QUIET MODE\_COOLING

TONNAGE	SOUND SUPPRESSION LEVEL	SOUND POWER LEVEL (dBA) <sup>1</sup>	SOUND PRESSURE LEVEL (dBA) <sup>2</sup>	Capacity Decrease
2-ton	LV.1	65	51	~5%
	LV.2	62	48	~15%
	LV.3	59	45	~35%
3-ton	LV.1	67	55	~5%
	LV.2	62	50	~30%
	LV.3	57	45	~35%
4-ton	LV.1	68	55	~5%
	LV.2	63	50	~30%
	LV.3	58	45	~45%
5-ton	LV.1	72	56	~5%
	LV.2	69	53	~25%
	LV.3	66	45	~50%

<sup>1</sup> Quiet Mode Sound Power and Sound Pressure levels determined at a distance of 3 [ft].

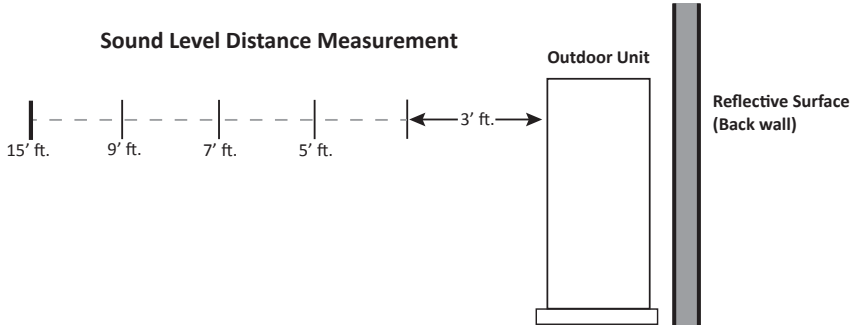

		SOUND PRESSURE (dBA) COOLING MODE <sup>1</sup>				
		DISTANCE FROM PROPERTY LINE				
TONNAGE	REFLECTIVE SURFACE QTY.	3'	5'	7'	9'	15'
2.0 Ton	0	60	55	52	50	46
	1	63	58	55	53	49
	2	66	61	58	56	52
3.0 Ton	0	64	59	56	54	50
	1	67	62	59	57	53
	2	70	65	62	60	56
4.0 Ton	0	66	61	58	56	52
	1	69	64	61	59	55
	2	72	67	64	62	58
5.0 Ton	0	70	65	62	60	56
	1	73	68	65	63	59
	2	76	71	68	66	62

<sup>1</sup> Compliant with AHRI 275 utilizing standard mode, total sound levels

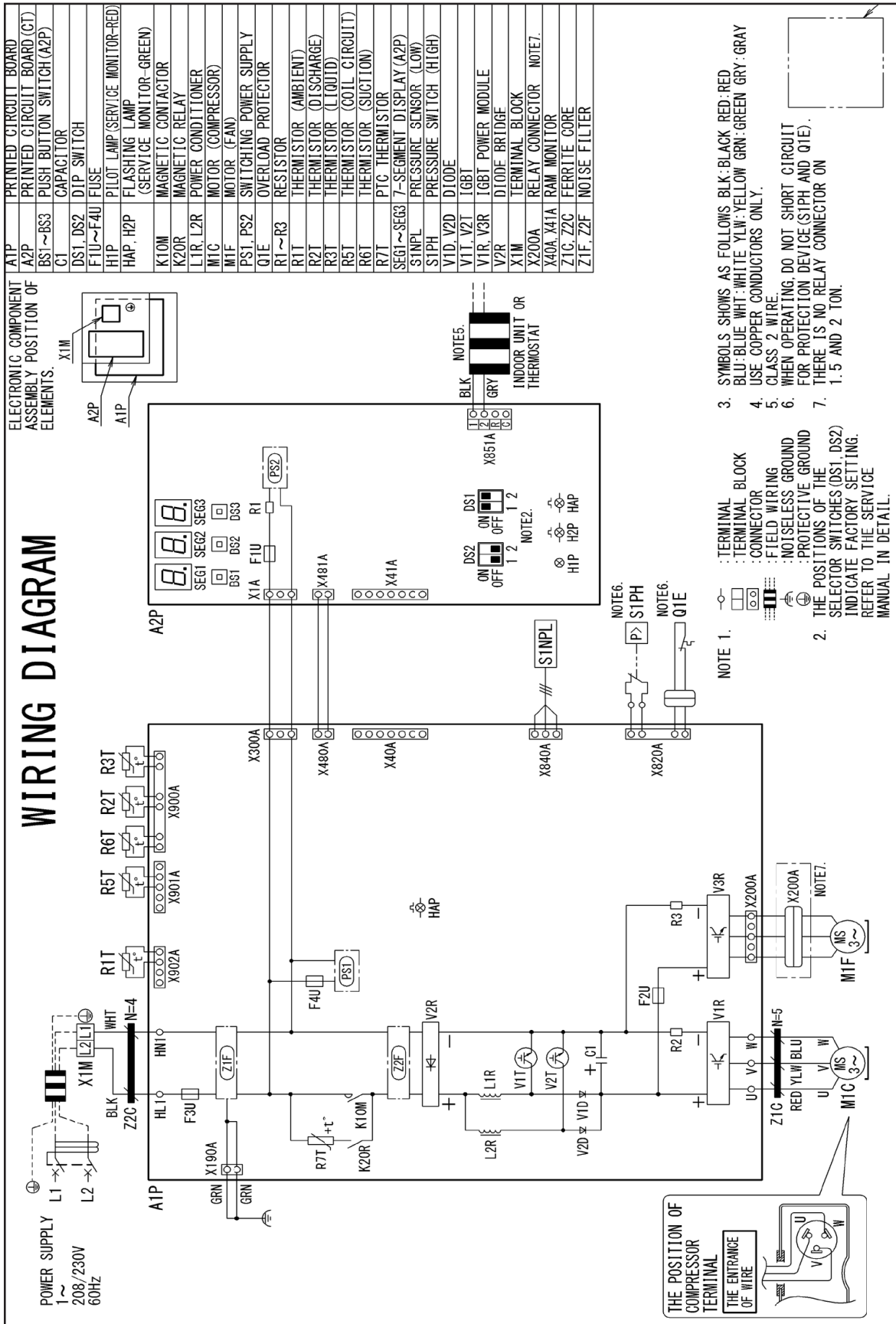

**WARNING**

**High Voltage:** Disconnect all power before servicing or installing this unit. Multiple power sources may be present. Failure to do so may cause property damage, personal injury, or death.

Wiring is subject to change. Always refer to the wiring diagram or the unit for the most up-to-date wiring.





MODEL	DIMENSIONS		
	W"	D"	H"
AXV9SA2410A*	36 $\frac{5}{8}$	13 $\frac{3}{4}$	27 $\frac{3}{8}$

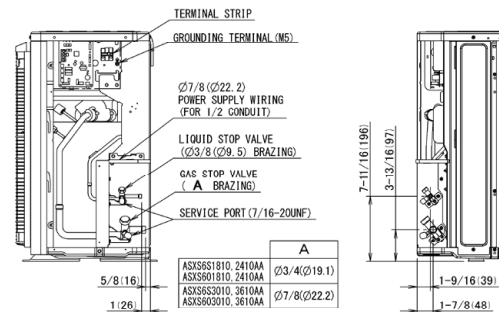
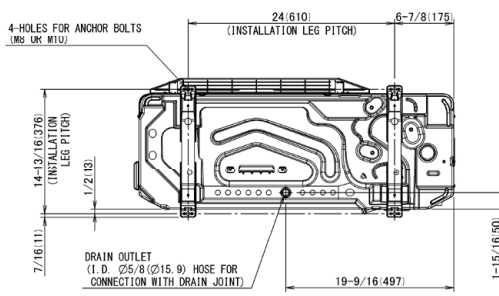
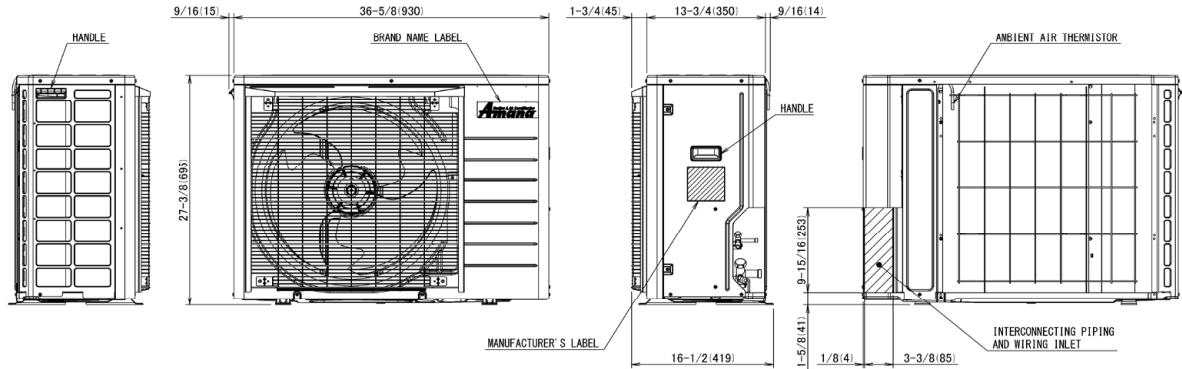

IN CASE OF REMOVING RIGHT SIDE PLATE

UNIT: inch (mm)

DIMENSIONS (CONT.)

MODEL	DIMENSIONS		
	W"	D"	H"
AXV9SA3610A*	37	12 $\frac{3}{8}$	39
AXV9SA3610A*	37	12 $\frac{3}{8}$	39

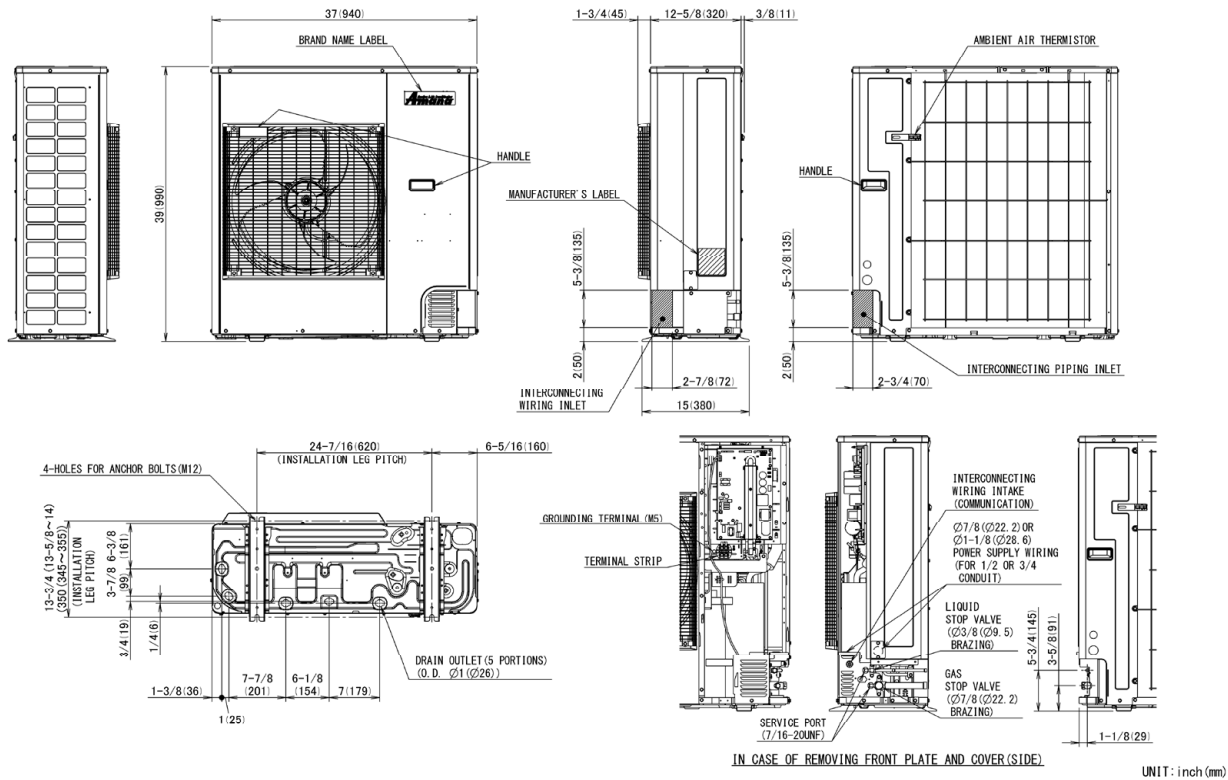

MODEL	DIMENSIONS		
	W"	D"	H"
AXV9SA6010A*	37	12%	56 <sup>5</sup> / <sub>16</sub>

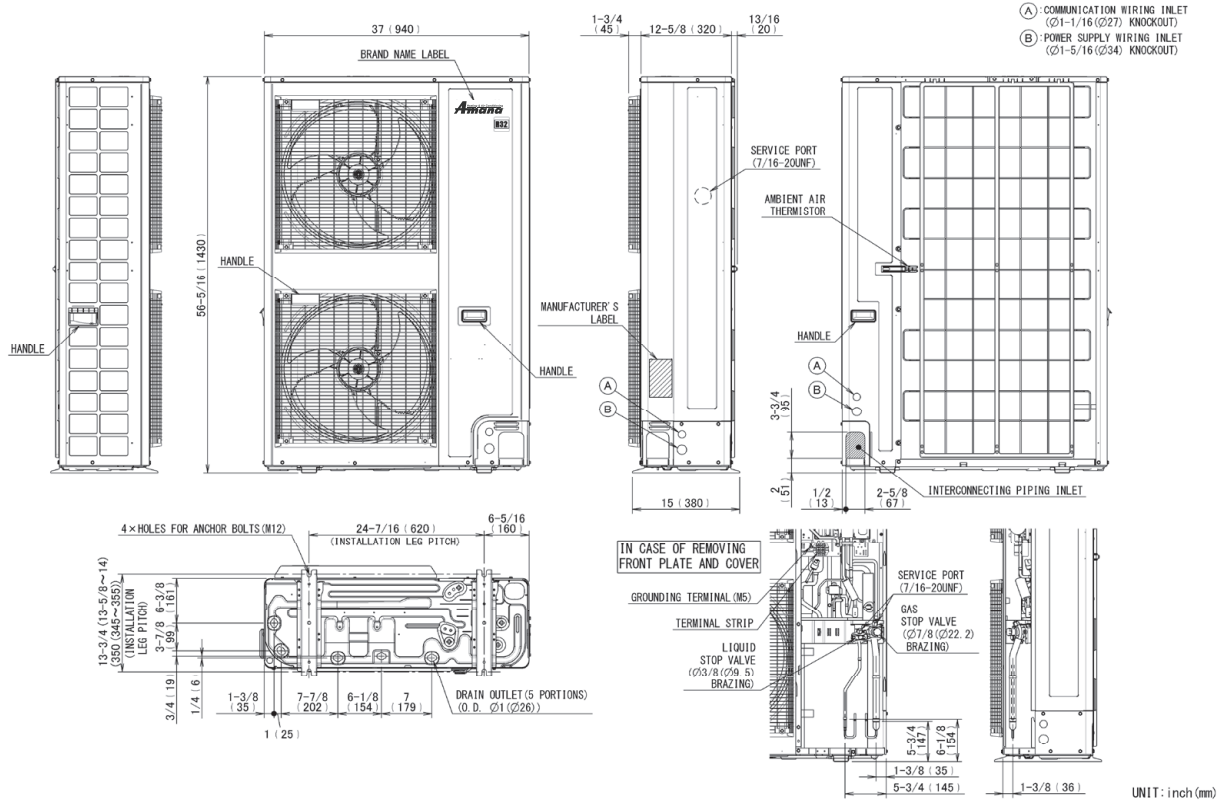

MODEL	DESCRIPTION	AXV9S A2410A*	AXV9S A3610A*	AXV9S A4810A*	AXV9S A6010A*
KPW5G112	Wind Baffle	X	X	X	X <sup>1</sup> (2)
130-DK-006	Hail Guard	X			
130-DK-008	Hail Guard		X	X	
DACA-WB-3	Powder Coated Wall-Mounted Bracket	X	X	X	
0270R02063 (130-DK-017)	Hail Guard				X
DSEN-HAQA	Daikin One Home Air Monitor				X

<sup>1</sup> Please ensure that 2 nos (KPW5G112) are ordered for each model when placing the order.

**All AHRI system ratings are accessible in the System Configurator tool via PartnerLink.**



